



Algorithm Reference

KURZWEIL
Music Systems

©1998 All rights reserved. Kurzweil is a product line of Young Chang Co.; V. A. S. T. is a registered trademark, and Kurzweil, K2500, and KDFX are trademarks of Young Chang Co. Hammond and Leslie are trademarks of Hammond Suzuki USA. SRS is a trademark of SRS Labs, Inc. All other products and brand names are trademarks or registered trademarks of their respective companies. Product features and specifications are subject to change without notice.

Part Number: 910319 Rev. A

FXAlg #1: MiniVerb • FXAlg #2: Dual MiniVerb

Versatile, small stereo and dual mono reverbs
Allocation Units: 1 for MiniVerb, 2 for Dual MiniVerb

MiniVerb is a versatile stereo reverb which is found in many combination algorithms, but is equally useful on its own because of its small size. The main control for this effect is the Room Type parameter. Room Type changes the structure of the algorithm to simulate many carefully crafted room types and sizes. Spaces characterized as booths, small rooms, chambers, halls and large spaces can be selected.

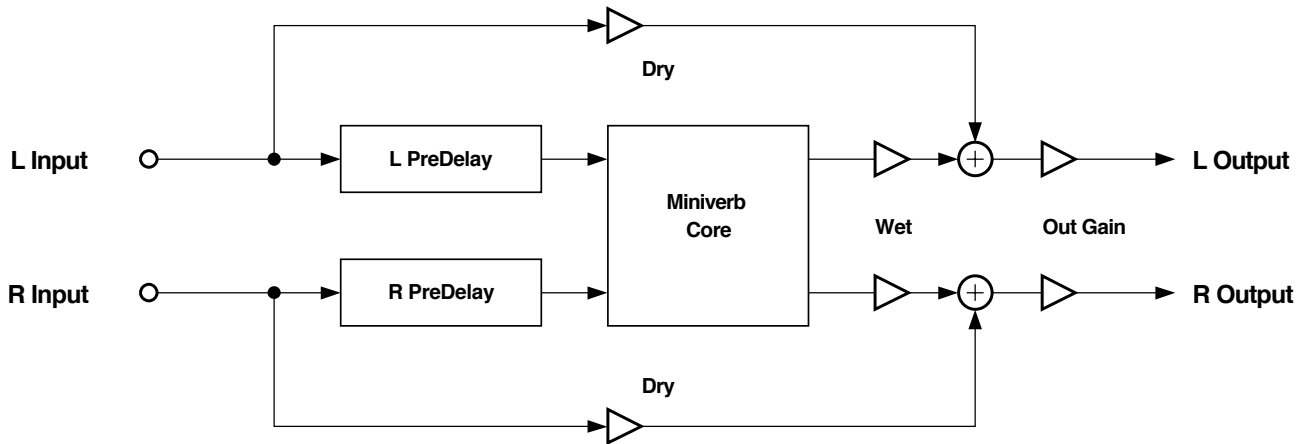

Simplified block diagram of MiniVerb

Each Room Type incorporates different diffusion, room size and reverb density settings. The Room Types were designed to sound best when Diff Scale, Size Scale and Density are set to the default values of 1.00x. If you want a reverb to sound perfect immediately, set the Diff Scale, Size Scale and Density parameters to 1.00x, pick a Room Type and you'll be on the way to a great sounding reverb. But if you want to experiment with new reverb flavors, changing the scaling parameters away from 1.00x can cause a subtle (or drastic!) coloring of the carefully crafted Room Types.

Diffusion characterizes how the reverb spreads the early reflections out in time. At very low settings of Diff Scale, the early reflections start to sound quite discrete, and at higher settings the early reflections are seamless. Density controls how tightly the early reflections are packed in time. Low Density settings have the early reflections grouped close together, and higher values spread the reflections for a smoother reverb.

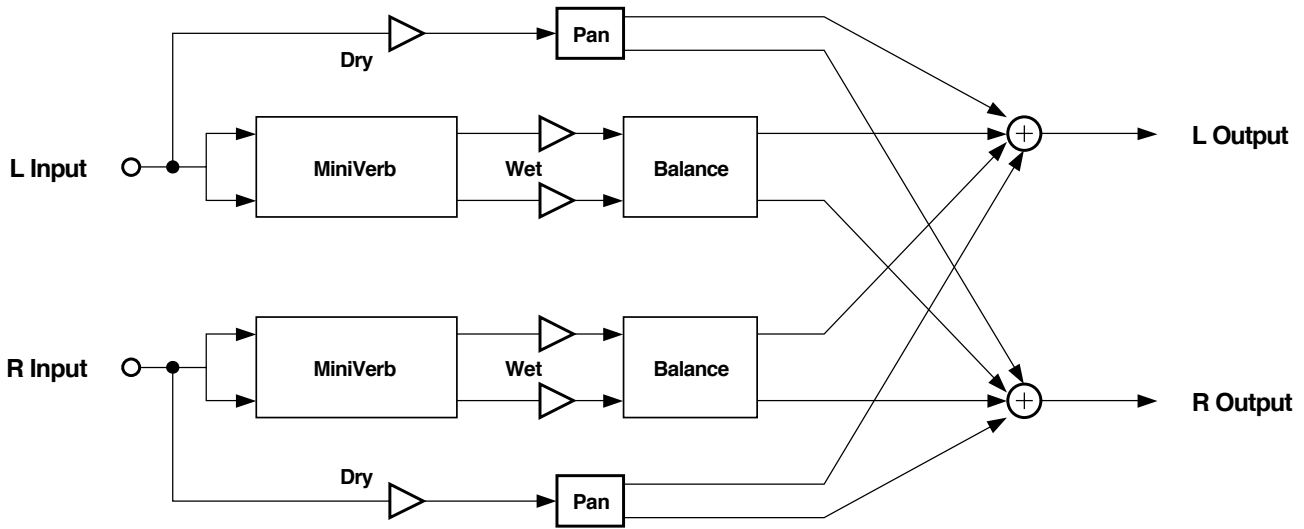

Simplified block diagram of Dual MiniVerb

Dual MiniVerb has a full MiniVerb, including Wet/Dry, Pre Delay and Out Gain controls, dedicated to each of the left and right channels. The two blocks in the diagram above labeled “MiniVerb” contain a complete copy of the MiniVerb on the previous page. Dual MiniVerb gives you independent reverbs on both channels which has obvious benefits for mono material. With stereo material, any panning or image placement can be maintained, even in the reverb tails. This is pretty unusual behavior for a reverb, since even real halls will rapidly delocalize acoustic images in the reverberance. Since maintaining image placement in the reverberation is so unusual, you will have to carefully consider whether it is appropriate for your particular situation. To use Dual MiniVerb to maintain stereo signals in this manner, set the reverb parameters for both channels to the same values. The Dry Pan and Wet Bal parameters should be fully left (-100%) for the left MiniVerb and fully right (100%) for the right MiniVerb.

Parameters (MiniVerb):

PAGE 1

Wet/Dry	0 to 100%wet	Out Gain	Off, -79.0 to 24.0 dB
Rvrb Time	0.5 to 30.0 s, Inf	HF Damping	16 to 25088 Hz
L Pre Dly	0 to 620 ms	R Pre Dly	0 to 620 ms

PAGE 2

Room Type	Hall1	Diff Scale	0.00 to 2.00x
		Size Scale	0.00 to 4.00x
		Density	0.00 to 4.00x

Parameters (Dual MiniVerb):

PAGE 1

L Wet/Dry	0 to 100%wet	R Wet/Dry	0 to 100%wet
L Out Gain	Off, -79.0 to 24.0 dB	R Out Gain	Off, -79.0 to 24.0 dB
L Wet Bal	-100 to 100%	R Wet Bal	-100 to 100%
L Dry Pan	-100 to 100%	R Dry Pan	-100 to 100%

PAGE 2

L RoomType	Hall1		
L RvrbTime	0.5 to 30.0 s, Inf		
L Diff Scl	0.00 to 2.00x	L Density	0.00 to 4.00x
L Size Scl	0.00 to 4.00x	L HF Damp	16 to 25088 Hz
L PreDlyL	0 to 620 ms	L PreDlyR	0 to 620 ms

PAGE 3

R RoomType	Hall1		
R RvrbTime	0.5 to 30.0 s, Inf		
R Diff Scl	0.00 to 2.00x	R Density	0.00 to 4.00x
R Size Scl	0.00 to 4.00x	R HF Damp	16 to 25088 Hz
R PreDlyL	0 to 620 ms	R PreDlyR	0 to 620 ms

- Wet/Dry A simple mix of the reverb sound with the dry sound.
- Out Gain The overall gain or amplitude at the output of the effect.
- Rvrb Time The reverb time displayed is accurate for normal settings of the other parameters (HF Damping = 25088kHz, and Diff Scale, Room Scale and Density = 1.00x). Changing Rvrb Time to Inf creates an infinitely sustaining reverb.
- HF Damping Reduces high-frequency components of the reverb above the displayed cutoff frequency. Removing higher reverb frequencies can often make rooms sound more natural.
- L/R Pre Dly The delay between the start of a sound and the output of the first reverb reflections from that sound. Longer pre-delays can help make larger spaces sound more realistic. Longer times can also help improve the clarity of a mix by separating the reverb signal from the dry signal, so the dry signal is not obscured. Likewise, the wet signal will be more audible if delayed, and thus you can get by with a dryer mix while maintaining the same subjective wet/dry level.
- Room Type Changes the configuration of the reverb algorithm to simulate a wide array of carefully designed room types and sizes. This parameter effectively allows you to have several different reverb algorithms only a parameter change away. Smaller Room Types will sound best with shorter Rvrb Times, and vice versa. (Note that since this parameter changes the structure of the reverb algorithm, you don't want to assign it a KDFX Modulation that will change it in real time.)
- Diff Scale A multiplier which affects the diffusion of the reverb. At 1.00x, the diffusion will be the normal, carefully-adjusted amount for the current Room Type. Altering this parameter will change the diffusion from the preset amount.

Size Scale

A multiplier which changes the size of the current room. At 1.00x, the room will be the normal, carefully-tweaked size of the current Room Type. Altering this parameter will change the size of the room, and thus will cause a subtle coloration of the reverb (since the room's dimensions are changing).

Density

A multiplier which affects the density of the reverb. At 1.00x, the room density will be the normal, carefully-set amount for the current Room Type. Altering this parameter will change the density of the reverb, which may color the room slightly.

Wet Bal

In Dual MiniVerb, two mono signals (left and right) are fed into two separate stereo reverbs. If you center the wet balance (0%), the left and right outputs of the reverb will be sent to the final output in equal amounts. This will add a sense of spaciousness.

FXAlg #3: Gated MiniVerb

A reverb and gate in series

Allocation Units: 2

This algorithm is a small reverb followed by a gate. The main control for the reverb is the Room Type parameter. Room Type changes the structure of the algorithm to simulate many carefully crafted room types and sizes. Spaces characterized as booths, small rooms, chambers, halls and large spaces can be selected. See the previous section (FXAlg #1-2) for details on the reverb.

The gate turns the output of the reverb on and off based on the amplitude of the input signal. One or both input channels is used to control whether the switch is on (gate is open) or off (gate is closed). This on/off control is called “side chain” processing. You select which of the two input channels or both is used for side chain processing. When you select both channels, the sum of the left and right input amplitudes is used.

The gate is opened when the side chain amplitude rises above a level that you specify with the Threshold parameter. The gate will stay open for as long as the side chain signal is above the threshold. When the signal drops below the threshold, the gate will remain open for the time set by the Gate Time parameter. At the end of the Gate Time, the gate closes. When the signal rises above threshold, it opens again. What is happening is that the gate timer is being constantly retriggered while the signal is above threshold.

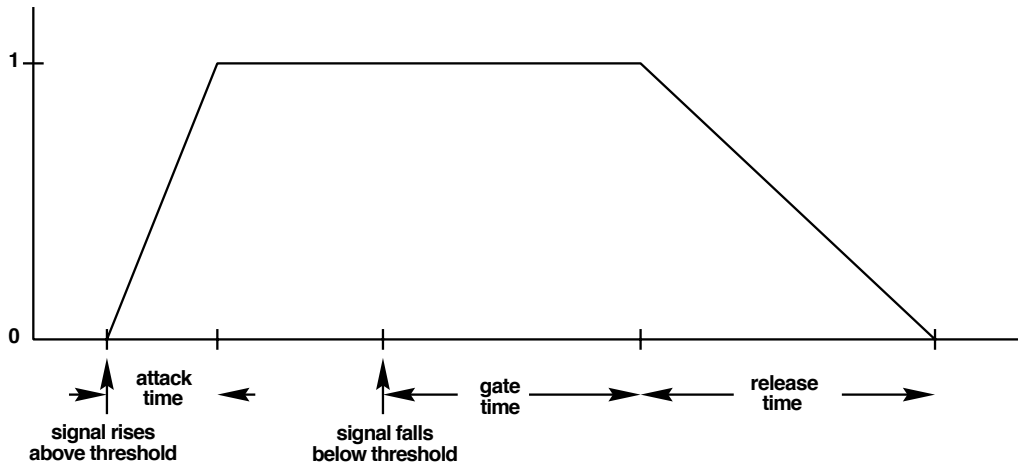

Gate Behavior

If Gate Duck is turned on, then the behavior of the gate is reversed. The gate is open while the side chain signal is below threshold, and it closes when the signal rises above threshold.

If the gate opened and closed instantaneously, you would hear a large digital click, like a big knife switch was being thrown. Obviously that’s not a good idea, so Gate Atk (attack) and Gate Rel (release) parameters are used to set the times for the gate to open and close. More precisely, depending on whether Gate Duck is off or on, Gate Atk sets how fast the gate opens or closes when the side chain signal rises above the threshold. The Gate Rel sets how fast the gate closes or opens after the gate timer has elapsed.

The Signal Dly parameter delays the signal being gated, but does not delay the side chain signal. By delaying the main signal relative to the side chain signal, you can open the gate just before the main signal rises above threshold. It’s a little like being able to pick up the telephone before it rings!

Parameters:

PAGE 1

Wet/Dry	0 to 100%wet	Out Gain	Off, -79.0 to 24.0 dB
Rvrb Time	0.5 to 30.0s, Inf	HF Damping	16 to 25088 Hz
L Pre Dly	0 to 620ms	R Pre Dly	0 to 620 ms

PAGE 2

Room Type	Hall1	Diff Scale	0.00 to 2.00x
		Size Scale	0.00 to 4.00x
		Density	0.00 to 4.00x

PAGE 3

Gate Thres	-79.0 to 0.0 dB	Gate Time	0 to 3000 ms
Gate Duck	In or Out	Gate Atk	0.0 to 228.0 ms
		Gate Rel	0 to 3000 ms
		GateSigDly	0.0 to 25.0 ms
Reduction			
-dB 60 40 * 16 * 8 4 0			

<u>Wet/Dry</u>	A simple mix of the reverb sound with the dry sound. When set fully dry (0%), the gate is still active.
<u>Out Gain</u>	An overall level control of the effect's output (applied after the gate).
<u>Gate Thres</u>	The input signal level in dB required to open the gate (or close the gate if Gate Duck is on).
<u>Gate Duck</u>	When set to "Off", the gate opens when the signal rises above threshold and closes when the gate time expires. When set to "On", the gate closes when the signal rises above threshold and opens when the gate time expires.
<u>Gate Time</u>	The time in seconds that the gate will stay fully on after the signal envelope rises above threshold. The gate timer is started or restarted whenever the signal envelope rises above threshold.
<u>Gate Atk</u>	The attack time for the gate to ramp from closed to open (reverse if Gate Duck is on) after the signal rises above threshold.
<u>Gate Rel</u>	The release time for the gate to ramp from open to closed (reverse if Gate Duck is on) after the gate timer has elapsed.
<u>Signal Dly</u>	The delay in milliseconds (ms) of the reverb input signal relative to the side chain signal. By delaying the reverb signal, the gate can be opened before the reverb signal rises above the gating threshold.

For descriptions of the other parameters, see the previous section, FXAlgs #1-2.

FXAlgs #4-11: Classic • TQ • Diffuse • Omni reverbs

FXAlg #4: Classic Place

FXAlg #5: Classic Verb

FXAlg #6: TQ Place

FXAlg #7: TQ Verb

FXAlg #8: Diffuse Place

FXAlg #9: Diffuse Verb

FXAlg #10: OmniPlace

FXAlg #11: OmniVerb

More Complex Reverb algorithms

Allocation Units: "Classic" 2; others 3

This set of 2 and 3 PAU sized algorithms can be divided into 2 groups: Verb and Place. Verb effects allow user friendly control over medium to large spaces. Their decay times are controlled by Rvrb Time or LateRvbTim parameters, and Room Types range from rooms to large areas. Place algorithms on the other hand are optimized for small spaces. Decay time is controlled by the Absorption parameter, and Room Types offers several booths.

Each of these reverb algorithms combines several components: a diffuser, an injector, predelay, an ambience generator with feedback, and various filters. These components provide sonic building blocks for both the early reflection portions and the body of the reverb.

The ambience generator is the heart of each reverb algorithm and creates most of the 'late' reverb in algorithms with an Early Reflections circuit. It is comprised of a complex arrangement of delay lines to disperse the sound. By using feedback in conjunction with the ambience generator, a reverb tail is produced. The length of this reverb tail is controlled by the Rvrb Time parameter in the "Verb" algorithms, or the Absorption parameter in "Place" algorithms.

In order to create reverbs that are smoother and richer, some of the delays in the ambience generator are moved by LFOs. The LFOs are adjusted by using the LFO Rate and LFO Depth controls. When used subtly, unwanted artifacts such as flutter and ringing that are inherent in digital reverbs can be reduced.

In the feedback loop of the ambience generator are filters that further enhance the sonic properties of each reverb. A lowpass filter is controlled by HF Damping. Its action mimics high-frequency energy being absorbed as the sound travels around a room. A low shelving filter is controlled by LF Split and LF Time, which are used to shorten or lengthen the decay time of low frequency energy.

At the beginning of each algorithm are diffusers. A diffuser creates an initial "smearing" quality on input signals usually before the signal enters the ambience generating loop. The DiffAmtScl and DiffLenScl parameters respectively change the amount and the length of time that the sound is smeared. The Diffuse reverbs, however, implement diffusion a little differently. See the section on Diffuse Verb and Diffuse Place below for detailed information.

Some algorithms use injector mechanisms when feeding a signal into the ambience generator. An injector creates copies of the input signal at different delay intervals and feeds each copy into the ambience generator at different points. This results in finer control over the onset of the reverb. By tapering the amplitudes of early copies vs. late copies, the initial build of the reverb can be controlled. Inj Build controls this taper. Negative values create a slower build, while positive values create a faster build. Inj Spread scales the length of all the copies as a group. Inj Skew (Omni reverbs) delays one channel relative to the other before injecting into the ambience generator. Negative values delay the left side while positive values delay the right side. Inj LP controls the cutoff frequency of a 1 pole (6dB/oct) lowpass filter associated with the injector.

Predelay can give the illusion that a space is more voluminous. Separate control over left and right predelay is provided which can be used to de-correlate the center image, increasing reverb envelopment.

In addition to filters inside the ambience feedback loop, there also may be filters placed at the output of the reverb including a low shelf, high shelf, and/or lowpass.

Algorithms that utilize Early Reflection circuits use a combination of delays, diffusers, and filters to create ambience that is sparser than the late portion of the reverb. These early reflections model the initial near-discrete echoes rebounding directly off of near field surfaces before the reverb has a chance to become diffuse. They add realism when emulating real rooms and halls.

The starting point when creating a new reverb preset should be the Room Type parameter. This parameter selects the basic type of reverb. Due to the inherent complexity of reverb algorithms and the sheer number of variables responsible for their character, the Room Type parameter provides condensed preset collections of these variables. Each Room Type collection has been painstakingly selected by Kurzweil engineers to provide the best-sounding combination of mutually complementary variables modeling an assortment of reverb families. When a room type is selected, an entire incorporated set of delay lengths and diffusion settings are established within the algorithm. By using the Size Scale, DiffAmtScl, DiffLenScl, and Inj Spread parameters, you may scale individual elements away from their pre-defined values. When set to 1.00x, each of these elements are accurately representing their preset values determined by the current Room Type.

Room Types with similar names in different reverb algorithms do not sound the same. For example, Hall1 in Diffuse Verb does not sound the same as Hall1 in TQ Verb.

The Size Scale parameter scales the inherent size of the reverb chosen by Room Type. For a true representation of the selected Room Type size, set this to 1.00x. Scaling the size below this will create smaller spaces, while larger scale factors will create large spaces.

The InfinDecay switch is designed to override the Rvrb Time parameter and create a reverb tail with an infinite decay time when 'On'. However, certain HF Damping settings may reduce this effect, and cause the tail to taper away. This parameter is an excellent candidate for a KDFX Modulation, using a switch pedal as a source.

Classic Verb and Classic Place:

Classic reverbs are 2-PAU algorithms with early reflections. The late portion consists of an input diffuser; ambience generator with low shelving filters, lowpass filters, and LFO moving delays; and predelay.

The early reflection portion consists of one delay per channel sent to its own output channel controlled by E Dly L and E Dly R, and one delay per channel sent to its opposite output channel controlled by E Dly LX and E Dly RX. Each of these delays also use a Diffuser. Diffusion lengths are separately controlled by E DifDly L, E DifDly R, E DifDly LX, and E DifDly RX while diffusion amounts are all adjusted with E DiffAmt.

The late reverb and early reflection portions are independently mixed together with the Late Lvl and EarRef Lvl controls. The wet signal is passed through a final high-shelving filter before being mixed with the dry signal.

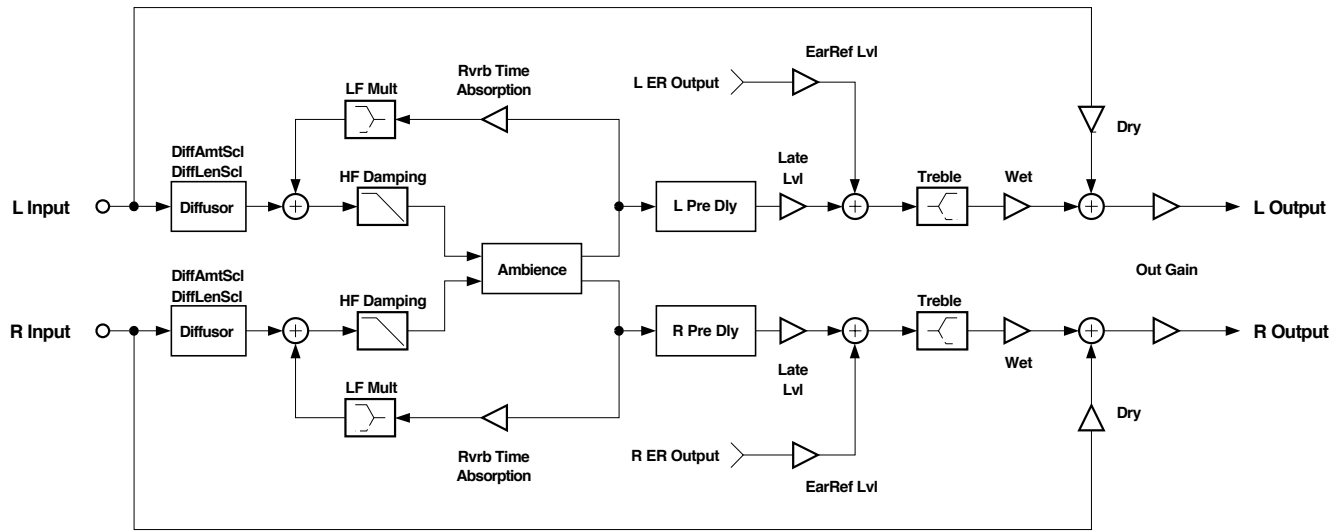

Signal flow of Classic Verb and Classic Place

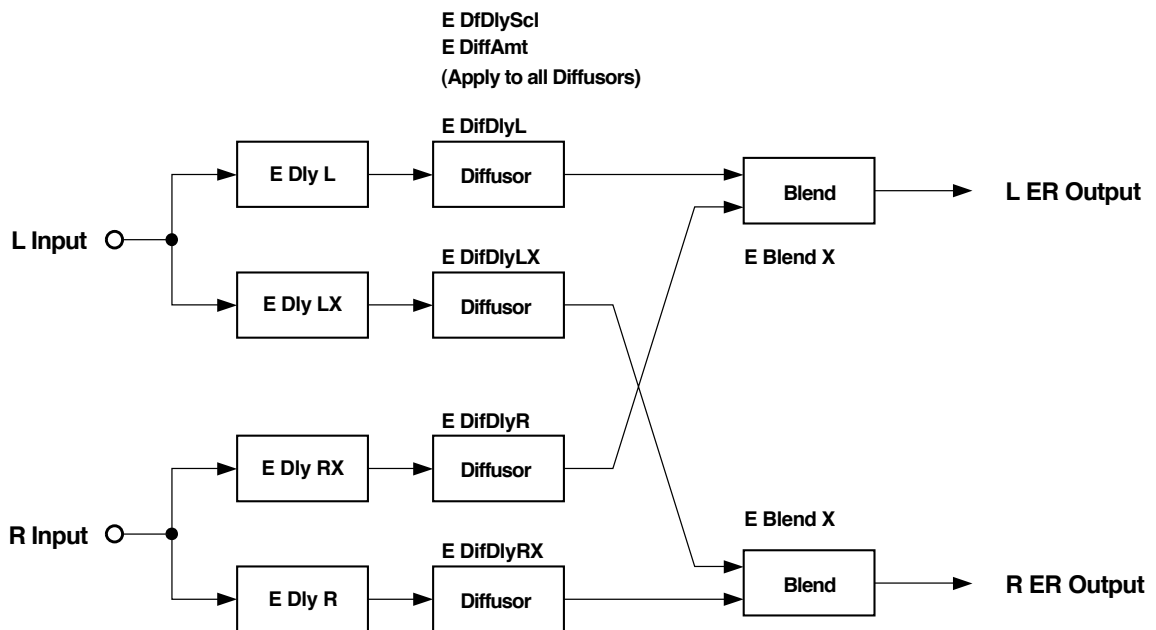

Early reflection portion of Classic Verb and Classic Place

PAGE 1 (Classic Verb)

Wet/Dry	-100 to 100%	Out Gain	Off; -79.0 to 24.0 dB
Rvrb Time	0.00 to 60.00 s	EarRef Lvl	-100 to 100%
HF Damping	0 to 25088 Hz	Late Lvl	-100 to 100%
L Pre Dly	0.0 to 230.0 ms	R Pre Dly	0.0 to 230.0 ms

PAGE 1 (Classic Place)

Wet/Dry	-100 to 100%	Out Gain	Off; -79.0 to 24.0 dB
Absorption	0 to 100%	EarRef Lvl	-100 to 100%
HF Damping	0 to 25088 Hz	Late Lvl	-100 to 100%
L Pre Dly	0.0 to 230.0 ms	R Pre Dly	0.0 to 230.0 ms

PAGE 2 (Classic Verb)

Room Type	Hall1, ...	DiffAmtScl	0.00 to 2.00 x
Size Scale	0.01 to 2.00x	DiffLenScl	0.00 to 2.00 x
InfinDecay	On or Off	LFO Rate	0.01 to 10.00 Hz
		LFO Depth	0.0 to 100.0 ct
TrebShlf F	16 to 25088 Hz	LF Split	16 to 25088 Hz
TrebShlf G	-79.0 to 24.0 dB	LF Time	0.50 to 1.50 x

PAGE 2 (Classic Place)

Room Type	Booth1, ...	DiffAmtScl	0.00 to 2.00 x
Size Scale	0.01 to 2.00x	DiffLenScl	0.00 to 2.00 x
		LFO Rate	0.01 to 10.00 Hz
		LFO Depth	0.0 to 100.0 ct
TrebShlf F	16 to 25088 Hz	LF Split	16 to 25088 Hz
TrebShlf G	-79.0 to 24.0 dB	LF Time	0.50 to 1.50 x

PAGE 3

E DfDlyScl	0.00 to 2.00 x	E X Blend	0 to 100%
E DiffAmt	-100 to 100%		
E Dly L	0.0 to 720.0 ms	E Dly R	0.0 to 720.0 ms
E Dly LX	0.0 to 720.0 ms	E Dly RX	0.0 to 720.0 ms
E DifDlyL	0.0 to 160.0 ms	E DifDlyR	0.0 to 160.0 ms
E DifDlyLX	0.0 to 230.0 ms	E DifDlyRX	0.0 to 230.0 ms

TQ Verb and TQ Place:

TQ reverbs are 3-PAU algorithms with early reflections. The late portion consists of an input diffuser, injector, ambience generator with a lowpass filter, low shelving filter, and LFO moving delays, and predelay.

The early reflection portion combines a combination of delays, diffusers, and feedback. The relative delay lengths are all fixed but are scalable with the E Dly Scl parameter. Relative diffusion lengths are also fixed, and are scalable with the E DfLenScl parameter. Diffusion amounts are adjusted with E DiffAmt. The E Build parameter ramps the gains associated with each delay line in a way that changes the characteristic of the onset of the early reflections. Negative amounts create a slower onset while positive amounts create a faster onset.

The late reverb and early reflection portions are independently mixed together with the Late Lvl and EarRef Lvl controls. The wet signal is passed through a final high shelving filter before being mixed with the dry signal.

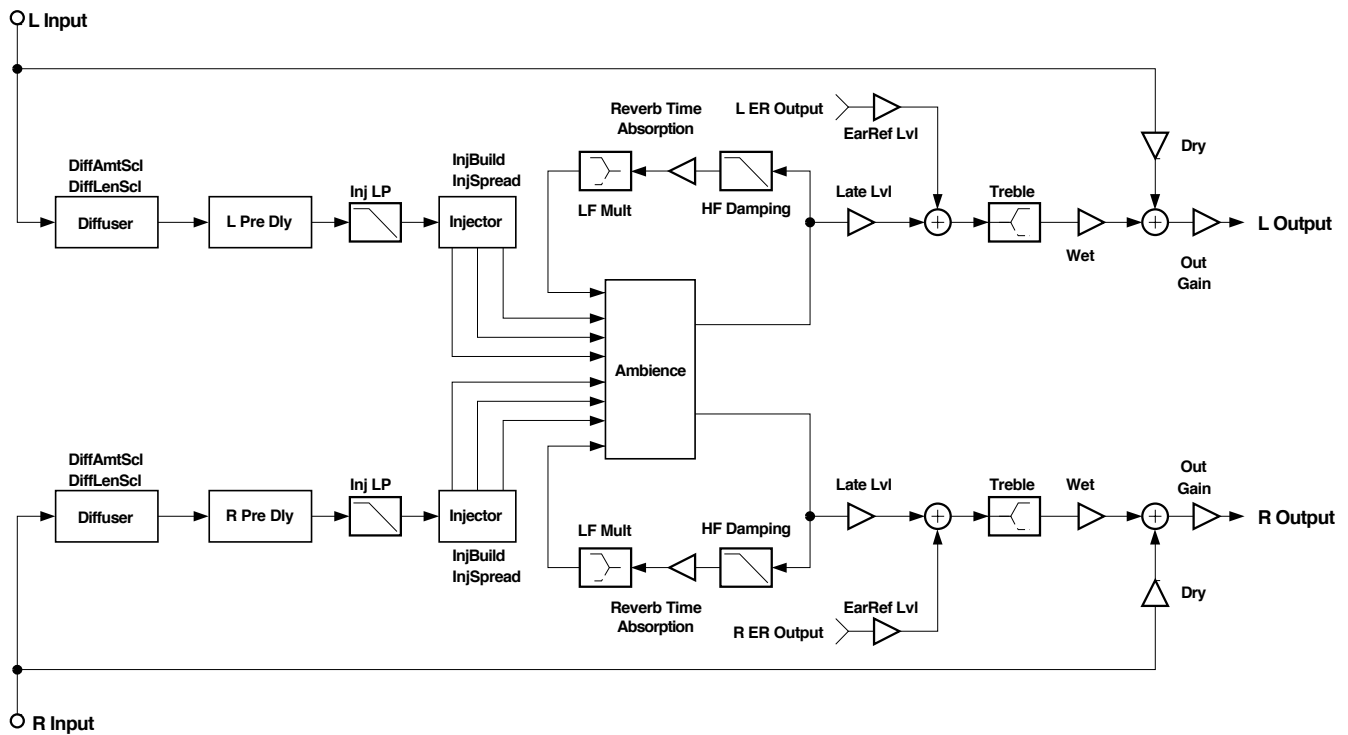

Signal flow of TQ Verb and TQ Place

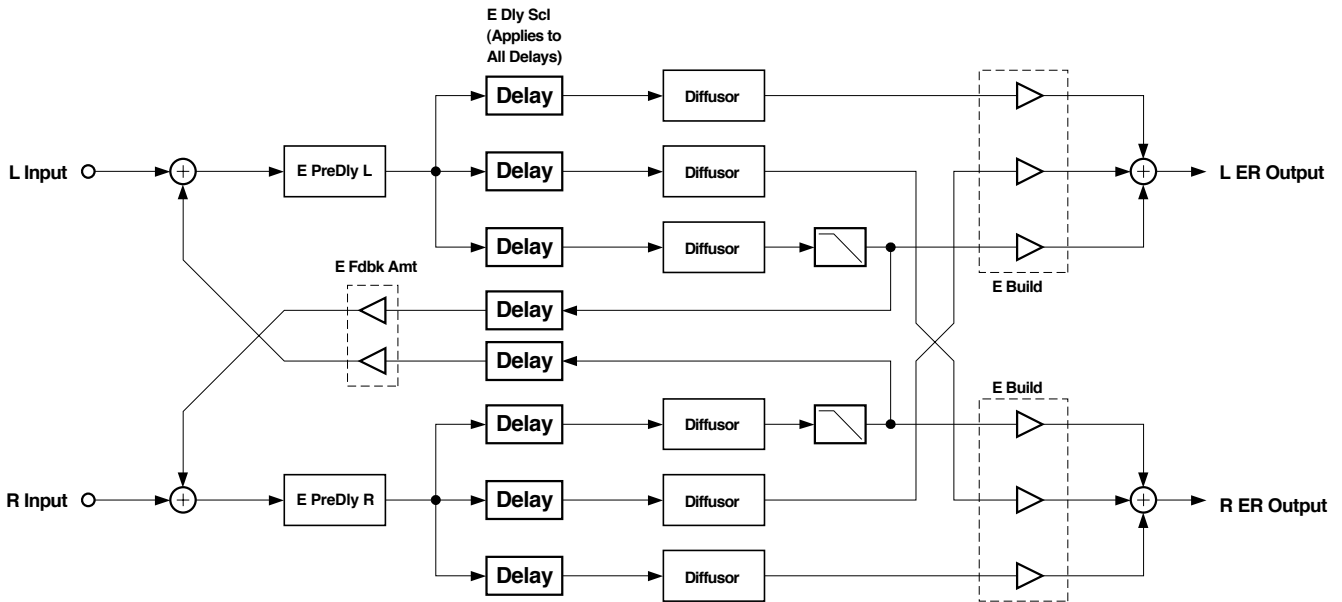

Early reflection portion of TQ Verb and TQ Place

PAGE 1 (TQ Verb)

Wet/Dry	-100 to 100%	Out Gain	Off; -79.0 to 24.0 dB
Rvrb Time	0.00 to 60.00 s	EarRef Lvl	-100 to 100%
HF Damping	0 to 25088 Hz	Late Lvl	-100 to 100%
L Pre Dly	0.0 to 230.0 ms	R Pre Dly	0.0 to 230.0 ms

PAGE 1 (TQ Place)

Wet/Dry	-100 to 100%	Out Gain	Off; -79.0 to 24.0 dB
Absorption	0 to 100%	EarRef Lvl	-100 to 100%
HF Damping	0 to 25088 Hz	Late Lvl	-100 to 100%
L Pre Dly	0.0 to 230.0 ms	R Pre Dly	0.0 to 230.0 ms

PAGE 2 (TQ Verb)

Room Type	Hall1, ...	TrebShlf F	16 to 25088 Hz
Size Scale	0.00 to 2.50x	TrebShlf G	-79.0 to 24.0 dB
InfinDecay	On or Off	DiffAmtScl	0.00 to 2.00 x
		DiffLenScl	0.00 to 2.50 x
LF Split	16 to 25088 Hz	LFO Rate	0.01 to 10.00 Hz
LF Time	0.50 to 1.50 x	LFO Depth	0.0 to 100.0 ct

PAGE 2 (TQ Place)

Room Type	Booth1, ...	TrebShlf F	16 to 25088 Hz
Size Scale	0.00 to 2.50x	TrebShlf G	-79.0 to 24.0 dB
		DiffAmtScl	0.00 to 2.00 x
		DiffLenScl	0.00 to 2.50 x
LF Split	16 to 25088 Hz	LFO Rate	0.01 to 10.00 Hz
LF Time	0.50 to 1.50 x	LFO Depth	0.0 to 100.0 ct

PAGE 3

Inj Build	-100 to 100%	Inj LP	16 to 25088 Hz
Inj Spread	0.00 to 2.50 x		
E DiffAmt	-100 to 100%	E Build	-100 to 100%
E DfLenScl	0.00 to 2.50 x	E Fdbk Amt	-100 to 100%
E DlyScl	0.00 to 2.50 x	E HF Damp	16 to 25088 Hz
E PreDlyL	0.0 to 150.0 ms	E PreDlyR	0.0 to 150.0 ms

Diffuse Verb and Diffuse Place:

Diffuse reverbs are 3-PAU algorithms and are characterized as such because of the initial burst of diffusion inherent in the onset of the reverb. Each of these algorithms consists of an input diffuser; ambience generator with a lowpass filter, low shelving filter, and LFO moving delays; and predelay.

In the Diffuse reverbs, the diffuser is implemented a little differently. The diffuser is just inside the ambience generation loop, so changes in diffusion create changes in the reverb decay. The Diffuse reverbs also offer DiffExtent and Diff Cross parameters. DiffExtent selects one of seven arbitrary gate-time lengths of the initial diffusion burst, while Diff Cross adjusts the combination of left and right channels that are diffused.

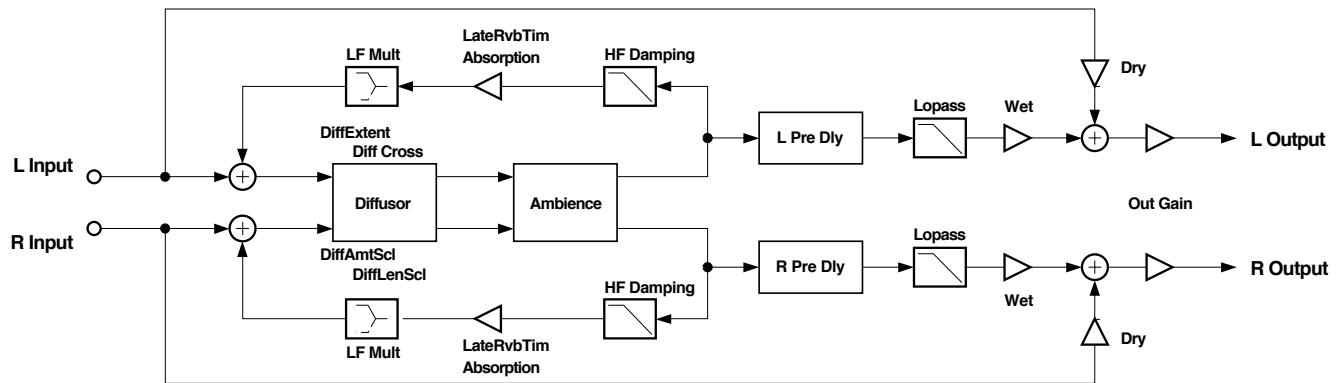

Signal flow of Diffuse Verb and Diffuse Place

PAGE 1 (Diffuse Verb)

Wet/Dry	-100 to 100%	Out Gain	Off; -79.0 to 24.0 dB
LateRvbTim	0.00 to 60.00 s		
HF Damping	0 to 25088 Hz	Lopass	16 to 25088 Hz
L Pre Dly	0.0 to 230.0 ms	R Pre Dly	0.0 to 230.0 ms

PAGE 1 (Diffuse Place)

Wet/Dry	-100 to 100%	Out Gain	Off; -79.0 to 24.0 dB
Absorption	0 to 100%		
HF Damping	0 to 25088 Hz	Lopass	16 to 25088 Hz
L Pre Dly	0.0 to 230.0 ms	R Pre Dly	0.0 to 230.0 ms

PAGE 2 (Diffuse Verb)

Room Type	Hall1,...	DiffExtent	1 to 7 x
Size Scale	0.01 to 2.50x	Diff Cross	-100 to 100%
InfinDecay	On or Off	DiffAmtScl	0.00 to 2.00 x
		DiffLenScl	0.01 to 2.50 x
LF Split	16 to 25088 Hz	LFO Rate	0.01 to 10.00 Hz
LF Time	0.50 to 1.50 x	LFO Depth	0.0 to 100.0 ct

PAGE 2 (Diffuse Place)

Room Type	Booth1, ...	DiffExtent	1 to 7 x
Size Scale	0.01 to 2.50x	Diff Cross	-100 to 100%
		DiffAmtScl	0.00 to 2.00 x
		DiffLenScl	0.01 to 2.50 x
LF Split	16 to 25088 Hz	LFO Rate	0.01 to 10.00 Hz
LF Time	0.50 to 1.50 x	LFO Depth	0.0 to 100.0 ct

OmniVerb and OmniPlace:

Omni reverbs are 3-PAU algorithms that consist of an input diffuser; injector; ambience generator with a lowpass filter, low shelving filter, and LFO moving delays; and predelay.

The Expanse parameter adjusts the amount of reverb energy that is fed to the edges of the stereo image. A value of 0% will concentrate energy in the center of the image, while non-zero values will spread it out. Positive and negative values will impose different characteristics on the reverb image.

At the output of the reverb are a pair each of low-shelving and high-shelving filters.

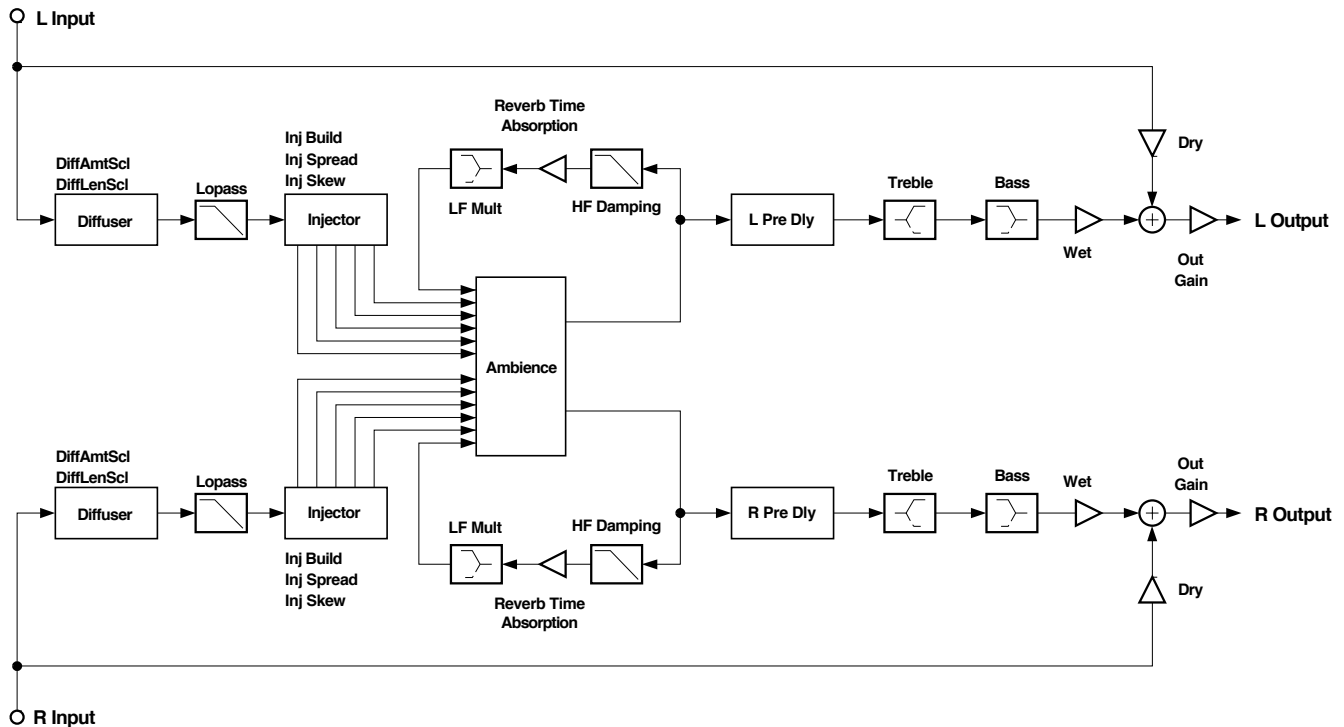

Signal flow of OmniVerb and OmniPlace

PAGE 1 (OmniVerb)

Wet/Dry	-100 to 100%	Out Gain	Off; -79.0 to 24.0 dB
Rvrb Time	0.00 to 60.00 s		
HF Damping	0 to 25088 Hz	Lopass	16 to 25088 Hz
L Pre Dly	0.0 to 230.0 ms	R Pre Dly	0.0 to 230.0 ms

PAGE 1 (OmniPlace)

Wet/Dry	-100 to 100%	Out Gain	Off; -79.0 to 24.0 dB
Absorption	0 to 100%		
HF Damping	0 to 25088 Hz	Lopass	16 to 25088 Hz
L Pre Dly	0.0 to 230.0 ms	R Pre Dly	0.0 to 230.0 ms

PAGE 2 (OmniVerb)

Room Type	Hall1, ...	Expanse	-100 to 100%
Size Scale	0.00 to 2.50x		
InfinDecay	On or Off	DiffAmtScl	0.00 to 2.00 x
		DiffLenScl	0.00 to 4.50 x
LF Split	16 to 25088 Hz	LFO Rate	0.01 to 10.00 Hz
LF Time	0.50 to 1.50 x	LFO Depth	0.0 to 100.0 ct

PAGE 2 (OmniPlace)

Room Type	Booth1, ...	Expanse	-100 to 100%
Size Scale	0.00 to 2.50x		
		DiffAmtScl	0.00 to 2.00 x
		DiffLenScl	0.00 to 4.50 x
LF Split	16 to 25088 Hz	LFO Rate	0.01 to 10.00 Hz
LF Time	0.50 to 1.50 x	LFO Depth	0.0 to 100.0 ct

PAGE 3

		TrebShlf F	16 to 25088 Hz
Inj Build	-100 to 100%	TrebShlf G	-79.0 to 24.0 dB
Inj Spread	0.00 to 4.50 x	BassShlf F	16 to 25088 Hz
Inj Skew	-200 to 200 ms	BassShlf G	-79.0 to 24.0 dB

Absorption

This controls the amount of reflective material that is in the space being emulated, much like an acoustical absorption coefficient. The lower the setting, the longer it will take for the sound to die away. A setting of 0% will cause an infinite decay time.

Rvrb Time

Adjusts the basic decay time of the late portion of the reverb.

LateRvrbTim

Adjusts the basic decay time of the late portion of the reverb after diffusion.

HF Damping

This controls the amount of high frequency energy that is absorbed as the reverb decays. The values set the cutoff frequency of the 1-pole (6dB/oct) lowpass filter within the reverb feedback loop.

L Pre Dly, R Pre Dly

These control the amount that each channel of the reverb is delayed relative to the dry signal. Setting different lengths for both channels can de-correlate the center portion of the reverb image and make it seem wider. This only affects the late reverb in algorithms that have early reflections.

Lopass

Controls the cutoff frequency of a 1-pole (6dB/oct) lowpass filter at the output of the reverb. This only affects the late reverb in algorithms that have early reflections.

EarRef Lvl

Adjusts the mix level of the early reflection portion of algorithms offering early reflections.

Late Lvl

Adjusts the mix level of the late reverb portion of algorithms offering early reflections.

<u>Room Type</u>	<p>This parameter selects the basic type of reverb being emulated, and should be the starting point when creating your own reverb presets. Due to the inherent complexity of reverb algorithms and the sheer number of variables responsible for their character, the Room Type parameter provides condensed preset collections of these variables. Each Room Type preset has been painstakingly selected by Kurzweil engineers to provide the best sounding collection of mutually complementary variables modeling an assortment of reverb families. When a room type is selected, an entire incorporated set of delay lengths and diffusion settings are established within the algorithm. By using the Size Scale, DiffAmtScl, DiffLenScl, and Inj Spread parameters, you may scale individual elements away from their preset value. When set to 1.00x, each of these elements is accurately representing its preset value determined by the current Room Type.</p> <p>Room Types with similar names in different reverb algorithms do not sound the same. For example, Hall1 in Diffuse Verb does not sound the same as Hall1 in TQ Verb.</p>
<u>Size Scale</u>	<p>This parameter scales the inherent size of the reverb chosen by Room Type. For a true representation of the selected Room Type size, set this to 1.00x. Scaling the size below this will create smaller spaces, while larger scale factors will create large spaces.</p>
<u>InfinDecay</u>	<p>Found in “Verb” algorithms. When turned “On”, the reverb tail will decay indefinitely. However, certain HF Damping settings may reduce this effect, and cause the tail to taper away. When turned “Off”, the decay time is determined by the “Rvrb Time” or “LateRvbTim” parameters. This parameter is an excellent candidate for a KDFX Modulation, using a switch pedal as a source.</p>
<u>LF Split</u>	<p>Used in conjunction with LF Time. This controls the upper-frequency limit of the low-frequency decay time multiplier. Energy below this frequency will decay faster or slower depending on the LF Time parameter.</p>
<u>LF Time</u>	<p>Used in conjunction with LF Split. This modifies the decay time of the energy below the LF Split frequency. A setting of 1.00x will make low-frequency energy decay at the rate determined by the decay time. Higher values will cause low-frequency energy to decay slower, and lower values will cause it to decay more quickly.</p>
<u>TrebShlf F</u>	<p>Adjusts the frequency of a high-shelving filter at the output of the late reverb.</p>
<u>TrebShlf G</u>	<p>Adjusts the gain of a high-shelving filter at the output of the late reverb.</p>
<u>BassShlf F</u>	<p>Adjusts the frequency of a low-shelving filter at the output of the late reverb.</p>
<u>BassShlf G</u>	<p>Adjusts the gain of a low-shelving filter at the output of the late reverb.</p>
<u>DiffAmtScl</u>	<p>Adjusts the amount of diffusion at the onset of the reverb. For a true representation of the selected Room Type diffusion amount, set this to 1.00x.</p>
<u>DiffLenScl</u>	<p>Adjusts the length of the diffusion at the onset of the reverb. For a true representation of the selected Room Type diffusion length, set this to 1.00x.</p>
<u>DiffExtent</u>	<p>Adjust the onset diffusion duration. Higher values create longer diffuse bursts at the onset of the reverb.</p>
<u>Diff Cross</u>	<p>Adjusts the onset diffusion cross-coupling character. Although subtle, this parameter bleeds left and right channels into each other during onset diffusion, and also in the body of the reverb. 0% setting will disable this. Increasing this value in either the positive or negative direction will increase its effect.</p>
<u>Expanse</u>	<p>Amount of late reverb energy biased toward the edges of the stereo image. A setting of 0% will bias energy towards the center. Moving away from 0% will bias energy towards the sides. Positive and negative values will have a different character.</p>

<u>LFO Depth</u>	Adjusts the detuning depth in cents caused by a moving reverb delay line. Moving delay lines can imitate voluminous flowing air currents and reduce unwanted artifacts like ringing and flutter when used properly. Depth settings under 1.5ct with LFO Rate settings under 1.00Hz are recommended for modeling real spaces. High depth settings can create chorusing qualities, which won't be suitable for real acoustic spaces, but can nonetheless create interesting effects. Instruments that have little or no inherent pitch fluctuation (like piano) are much more sensitive to this LFO than instruments that normally have a lot of vibrato (like voice) or non-pitched instruments (like snare drum).
<u>LFO Rate</u>	Adjusts the rate at which the moving reverb delay lines move.
<u>Inj Build</u>	Used in conjunction with Inj Spread, this adjusts the envelope of the onset of the reverb. Specifically, it tapers the amplitudes of a series of delayed signals injected into the body of the reverb. Values above 0% will produce a faster build, while values below 0% will cause the build to be more gradual.
<u>Inj Spread</u>	Used in conjunction with Inj Build, this scales the length of the series of delays injected into the body of the reverb. For a true representation of the selected Room Type injector spread, set this to 1.00x.
<u>Inj LP</u>	This adjusts the cutoff frequency of a 1 pole (6dB/oct) lowpass filter applied to the signal being injected into the body of the reverb.
<u>Inj Skew</u>	Adjusts the amount of delay applied to either the left or right channel of the reverb injector. Positive values delay the right channel while negative values delay the left channel.
<u>E DiffAmt</u>	Adjusts the amount of diffusion applied to the early reflection network.
<u>E DfLenScl</u>	Adjusts the length of diffusion applied to the early reflection network. This is influenced by E PreDlyL and E PreDlyR.
<u>E Dly Scl</u>	Scales the delay lengths inherent in the early reflection network.
<u>E Build</u>	Adjusts the envelope of the onset of the early reflections. Values above 0% will create a faster attack while values below 0% will create a slower attack.
<u>E Fdbk Amt</u>	Adjusts the amount of the output of an early reflection portion that is fed back into the input of the opposite channel in front of the early pre-delays. Overall, it lengthens the decay rate of the early reflection network. Negative values polarity-invert the feedback signal.
<u>E HF Damp</u>	This adjusts the cutoff frequency of a 1-pole (6dB/oct) lowpass filter applied to the early reflection feedback signal.
<u>E PreDlyL, E PreDlyR</u>	Adjusts how much the early reflections are delayed relative to the dry signal. These are independent of the late reverb predelay times, but will influence E Dly Scl.
<u>E Dly L, E Dly R</u>	Adjusts the left and right early reflection delays fed to the same output channels.
<u>E Dly LX, E Dly RX</u>	Adjusts the left and right early reflection delays fed to the opposite output channels.
<u>E DifDlyL, E DifDlyR</u>	Adjusts the diffusion delays of the diffusers on delay taps fed to the same output channels.
<u>E DifDlyLX, E DifDlyRX</u>	Adjusts the diffusion delays of the diffusers on delay taps fed to the opposite output channels.
<u>E X Blend</u>	Adjusts the balance between early reflection delay tap signals with diffusers fed to their same output channel, and those fed to opposite channels. 0% allows only delay taps being fed to opposite output channels to be heard, while 100% allows only delay taps going to the same channels to be heard.

FXAlg #12: Panaural Room

Room reverberation algorithm

Allocation Units: 3

The Panaural Room reverberation is implemented using a special network arrangement of many delay lines that guarantees colorless sound. The reverberator is inherently stereo with each input injected into the “room” at multiple locations. The signals entering the reverberator first pass through a shelving bass equalizer with a range of +/-15dB. To shorten the decay time of high frequencies relative to mid frequencies, lowpass filters controlled by HF Damping are distributed throughout the network. Room Size scales all the delay times of the network (but not the Pre Dly or Build Time), to change the simulated room dimension over a range of 1 to 16m. Decay Time varies the feedback gains to achieve decay times from 0.5 to 100 seconds. The Room Size and Decay Time controls are interlocked so that a chosen Decay Time will be maintained while Room Size is varied. A two-input stereo mixer, controlled by Wet/Dry and Out Gain, feeds the output.

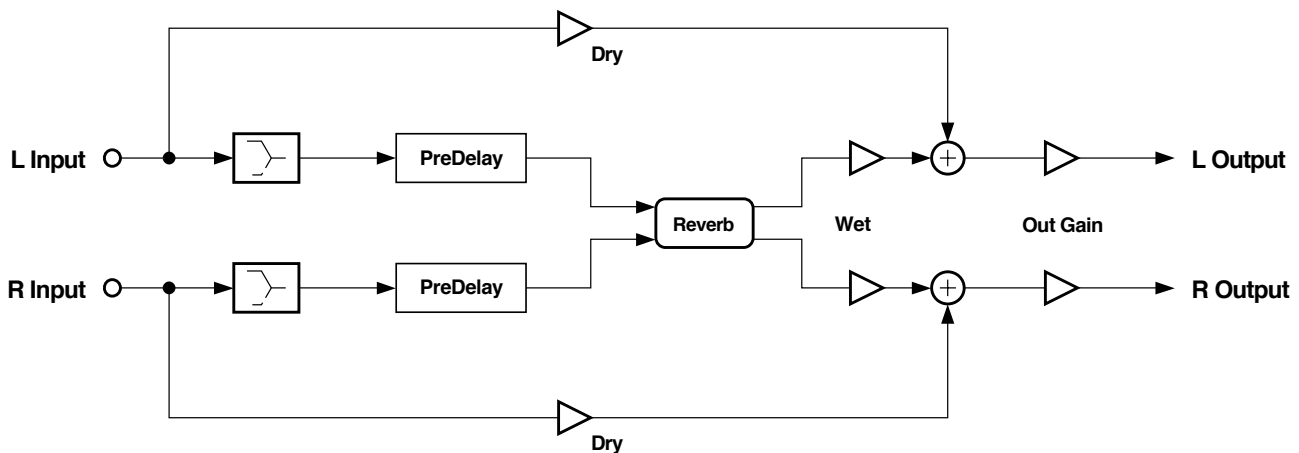

Simplified block diagram of Panaural Room.

The duration and spacing of the early reflections are influenced by Room Size and Build Time, while the number and relative loudness of the individual reflections are influenced by Build Env. When Build Env is near 0 or 100%, fewer reflections are created. The maximum number of important early reflections, 13, is achieved at a setting of 50%.

To get control over the growth of reverberation, the left and right inputs each are passed through an “injector” that can extend the source before it drives the reverberator. Only when Build Env is set to 0% is the reverberator driven in pure stereo by the pure dry signal. For settings of Build Env greater than 0%, the reverberator is fed multiple times. Build Env controls the injector so that the reverberation begins abruptly (0%), builds immediately to a sustained level (50%), or builds gradually to a maximum (100%). Build Time varies the injection length over a range of 0 to 500ms. At a Build Time of 0ms, there is no extension of the build time. In this case, the Build Env control adjusts the density of the reverberation, with maximum density at a setting of 50%. In addition to the two build controls, there is an overall Pre Dly control that can delay the entire reverberation process by up to 500ms.

Parameters:

PAGE 1

Wet/Dry	0 to 100%wet	Out Gain	Off, -79.0 to 24.0
Room Size	1.0 to 16.0 m		
Pre Dly	0 to 500 ms	Decay Time	0.5 to 100.0 s
HF Damping	16 to 25088 Hz		

PAGE 2

Bass Gain	-15 to 15 dB	Build Time	0 to 500 ms
		Build Env	0 to 100%

- Wet/Dry The amount of the stereo reverberator (wet) signal relative to the original input (dry) signal to be output. The dry signal is not affected by the Bass Gain control. The wet signal is affected by the Bass Gain control and by all the other reverberator controls. The balance between wet and dry signals is an extremely important factor in achieving a good mix. Emphasizing the wet signal gives the effect of more reverberation and of greater distance from the source.
- Out Gain The overall output level for the reverberation effect, and controls the level for both the wet and dry signal paths.
- Decay Time The reverberation decay time (mid-band “RT₆₀”), the time required before the reverberation has died away to 60dB below its “running” level. Adjust decay time according to the tempo and articulation of the music and to taste.
- HF Damping Adjusts lowpass filters in the reverberator so that high frequencies die away more quickly than mid and low frequencies. This shapes the reverberation for a more natural, more acoustically accurate sound.
- Bass Gain Shapes the overall reverberation signal’s bass content, but does not modify the decay time. Reduce the bass for a less muddy sound, raise it slightly for a more natural acoustic effect.
- Room Size Choosing an appropriate room size is very important in getting a good reverberation effect. For impulsive sources, such as percussion instruments or plucked strings, increase the size setting until discrete early reflections become audible, and then back it off slightly. For slower, softer music, use the largest size possible. At lower settings, Room Size leads to coloration, especially if the Decay Time is set too high.
- Pre Dly Introducing predelay creates a gap of silence that allows the dry signal to stand out with greater clarity and intelligibility against the reverberant background. This is especially helpful with vocal or classical music.
- Build Time Similar to predelay, but more complex, larger values of Build Time slow down the building up of reverberation and can extend the build-up process. Experiment with Build Time and Build Env and use them to optimize the early details of reverberation. A Build Time of 0ms and a Build Env of 50% is a good default setting that yields a fast arriving, maximally dense reverberation.

Build Env

When Build Time has been set to greater than about 80ms, Build Env begins to have an audible influence on the early unfolding of the reverberation process. For lower-density reverberation that starts cleanly and impulsively, use a setting of 0%. For the highest-density reverberation, and for extension of the build-up period, use a setting of 50%. For an almost reverse reverberation, set Build Env to 100%. You can think of Build Env as setting the position of a see-saw. The left end of the see-saw represents the driving of the reverberation at the earliest time, the pivot point as driving the reverberation at mid-point in the time sequence, and the right end as the last signal to drive the reverberator. At settings near 0%, the see-saw is tilted down on the right: the reverberation starts abruptly and the drive drops with time. Near 50%, the see-saw is level and the reverberation is repeatedly fed during the entire build time. At settings near 100%, the see-saw is tilted down on the left, so that the reverberation is hit softly at first, and then at increasing level until the end of the build time.

FXAlg #13: Stereo Hall

A stereo hall reverberation algorithm

Allocation Units: 3

The Stereo Hall reverberation is implemented using a special arrangement of all pass networks and delay lines, which reduces coloration and increases density. The reverberator is inherently stereo with each input injected into the “room” at multiple locations. To shorten the decay time of low and high frequencies relative to mid frequencies, bass equalizers and lowpass filters, controlled by Bass Gain and by HF Damping, are placed within the network. Room Size scales all the delay times of the network (but not the Pre Dly or Build Time), to change the simulated room dimension over a range of 10 to 75m. Decay Time varies the feedback gains to achieve decay times from 0.5 to 100 seconds. The Room Size and Decay Time controls are interlocked so that a chosen Decay Time will be maintained while Room Size is varied. At smaller sizes, the reverb becomes quite colored and is useful only for special effects. A two-input stereo mixer, controlled by Wet/Dry and Out Gain, feeds the output. The Lowpass control acts only on the wet signal and can be used to smooth out the reverb high end without modifying the reverb decay time at high frequencies.

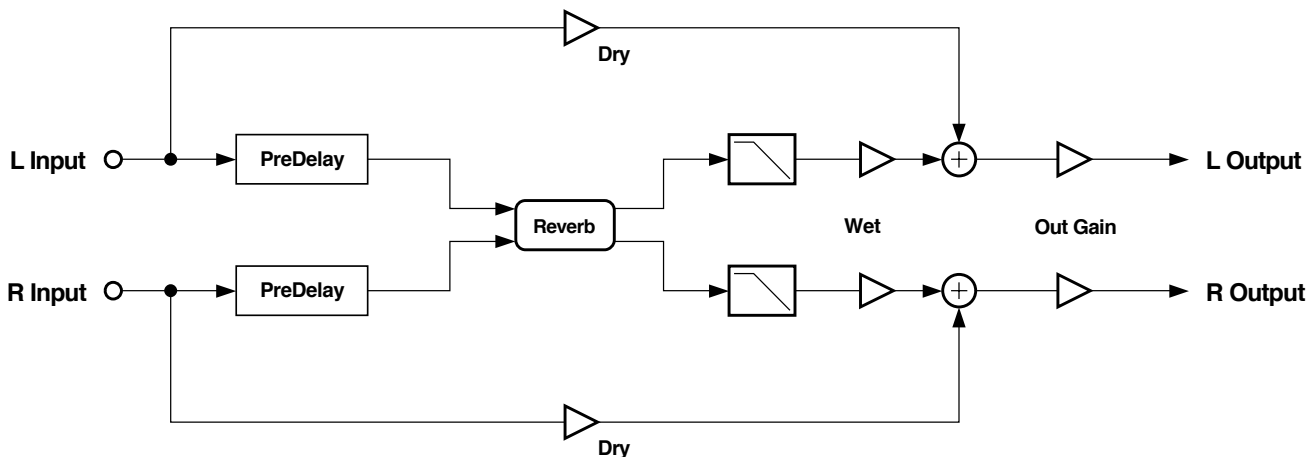

Simplified block diagram of Stereo Hall.

Within the reverberator, certain delays can be put into a time varying motion to break up patterns and to increase density in the reverb tail. Using the LFO Rate and Depth controls carefully with longer decay times can be beneficial. But beware of the pitch-shifting artifacts which can accompany randomization when it is used in greater amounts. Also within the reverberator, the Diffusion control can reduce the diffusion provided by some all pass-networks. While the reverb will eventually reach full diffusion regardless of the Diffusion setting, the early reverb diffusion can be reduced, which sometimes is useful to help keep the dry signal “in the clear”.

The reverberator structure is stereo and requires that the dry source be applied to both left and right inputs. If the source is mono, it should still be applied (pan centered) to both left and right inputs. Failure to drive both inputs will result in offset initial reverb images and later ping-ponging of the reverberation. Driving only one input will also increase the time required to build up reverb density.

To gain control over the growth of reverberation, the left and right inputs each are passed through an “injector” that can extend the source before it drives the reverberator. Only when Build Env is set to 0% is the reverberator driven in pure stereo by the pure dry signal. For settings of Build Env greater than 0%, the reverberator is fed multiple times. Build Env controls the injector so that the reverberation begins abruptly (0%), builds immediately to a sustained level (50%), or builds gradually to a maximum (100%). Build Time varies the injection length over a range of 0 to 500ms. At a Build Time of 0ms, there is no extension of the build time. In this case, the Build Env control adjusts the density of the reverberation, with maximum density at a setting of 50%. In addition to the two build controls, there is an overall Pre Dly control that can delay the entire reverberation process by up to 500ms.

Parameters:

PAGE 1

Wet/Dry	0 to 100%wet	Out Gain	Off, -79.0 to 24.0 dB
Room Size	2.0 to 15.0 m	Diffusion	0 to 100%
Pre Dly	0 to 500 ms	Decay Time	0.5 to 100.0 ms
HF Damping	16 to 25088 Hz		

PAGE 2

Bass Gain	-15 to 0 dB	Build Time	0 to 500 ms
Lowpass	16 to 25088 Hz	Build Env	0 to 100%
LFO Rate	0.00 to 5.10 Hz		
LFO Depth	0.00 to 10.20 ct		

Wet/Dry

The amount of the stereo reverberator (wet) signal relative to the original input (dry) signal to be output. The dry signal is not affected by the Bass Gain control. The wet signal is affected by the Bass Gain control and by all the other reverberator controls. The balance between wet and dry signals is an extremely important factor in achieving a good mix. Emphasizing the wet signal gives the effect of more reverberation and of greater distance from the source.

Out Gain

The overall output level for the reverberation effect, and controls the level for both the wet and dry signal paths.

Decay Time

The reverberation decay time (mid-band “RT₆₀”), the time required before the reverberation has died away to 60dB below its “running” level. Adjust decay time according to the tempo and articulation of the music and to taste.

HF Damping

Adjusts lowpass filters in the reverberator so that high frequencies die away more quickly than mid and low frequencies. This shapes the reverberation for a more natural, more acoustically accurate sound.

Room Size

Choosing an appropriate room size is very important in getting a good reverberation effect. For impulsive sources, such as percussion instruments or plucked strings, increase the size setting until discrete early reflections become audible, and then back it off slightly. For slower, softer music, use the largest size possible. At lower settings, RoomSize leads to coloration, especially if the DecayTime is set too high.

Bass Gain

Adjusts bass equalizers in the reverberator so that low frequencies die away more quickly than mid and high frequencies. This can be used to make the reverberation less muddy.

FXAlg #13: Stereo Hall

<u>Lowpass</u>	Used to shape the overall reverberation signal's treble content, but does not modify the decay time. Reduce the treble for a softer, more acoustic sound.
<u>Pre Dly</u>	Introducing predelay creates a gap of silence that allows the dry signal to stand out with greater clarity and intelligibility against the reverberant background. This is especially helpful with vocal or classical music.
<u>Build Time</u>	Similar to predelay, but more complex, larger values of BuildTime slow down the building up of reverberation and can extend the build up process. Experiment with BuildTime and BuildEnv and use them to optimize the early details of reverberation. A BuildTime of 0ms and a BuildEnv of 50% is a good default setting that yields fast arriving, natural reverberation.
<u>Build Env</u>	When BuildTime has been set to greater than about 80ms, BuildEnv begins to have an audible influence on the early unfolding of the reverberation process. For lower-density reverberation that starts cleanly and impulsively, use a setting of 0%. For the highest-density reverberation, and for extension of the build-up period, use a setting of 50%. For an almost reverse reverberation, set BuildEnv to 100%. You can think of BuildEnv as setting the position of a see-saw. The left end of the see-saw represents the driving of the reverberation at the earliest time, the pivot point as driving the reverberation at mid-point in the time sequence, and the right end as the last signal to drive the reverberator. At settings near 0%, the see-saw is tilted down on the right: the reverberation starts abruptly and the drive drops with time. Near 50%, the see-saw is level and the reverberation is repeatedly fed during the entire build time. At settings near 100%, the see-saw is tilted down on the left, so that the reverberation is hit softly at first, and then at increasing level until the end of the build time.
<u>LFO Rate and LFO Depth</u>	Within the reverberator, the certain delay values can be put into a time varying motion to break up patterns and to increase density in the reverb tail. Using the LFO Rate and Depth controls carefully with longer decay times can be beneficial. But beware of the pitch-shifting artifacts which can accompany randomization when it is used in greater amounts.
<u>Diffusion</u>	Within the reverberator, the Diffusion control can reduce the diffusion provided by some of the all-pass networks. While the reverb will eventually reach full diffusion regardless of the Diffusion setting, the early reverb diffusion can be reduced, which sometimes is useful to help keep the dry signal "in the clear."

FXAlg #14: Grand Plate

A plate reverberation algorithm

Allocation Units: 3

This algorithm emulates an EMT 140 steel plate reverberator. Plate reverberators were manufactured during the 1950s, 60s, 70s, and perhaps into the 80s. By the end of the 1980s, they had been supplanted in the marketplace by digital reverberators, which first appeared in 1976. While a handful of companies made plate reverberators, EMT (Germany) was the best known and most popular.

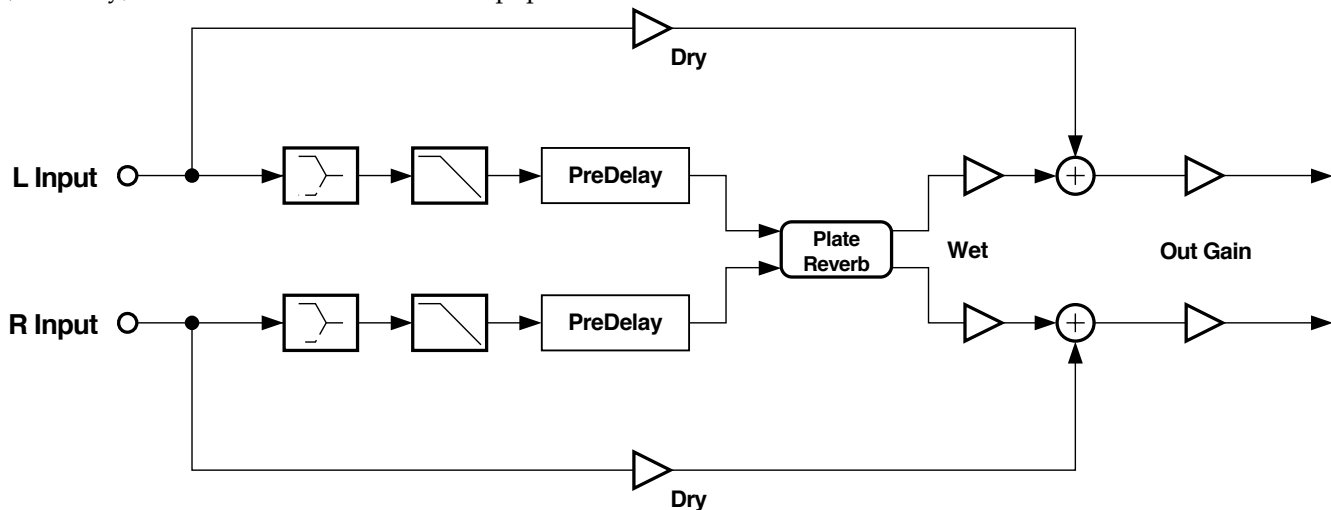

Diagram of Grand Plate reverb

A plate reverberator is generally quite heavy and large, perhaps 4 feet high by 7 feet long, and a foot thick. They were only slightly adjustable, with controls for high frequency damping and decay time. Some were stereo in/stereo out, others mono in/mono out.

A plate reverb begins with a sheet of plate steel suspended by its edges, leaving the plate free to vibrate. At one (or two) points on the plate, an electromagnetic driver (sort of a small loudspeaker without a cone) is arranged to couple the dry signal into the plate, sending sound vibrations into the plate in all directions. At one or two other locations, a pickup is placed, sort of like a dynamic microphone whose diaphragm is the plate itself, to pick up the reverberation.

Since the sound waves travel very rapidly in steel (faster than they do in air), and since the dimensions of the plate are not large, the sound quickly reaches the plate edges and reflects from them. This results in a very rapid build-up of the reverberation, essentially free of early reflections and with no distinguishable gap before the onset of reverb.

Plates offered a wonderful sound of their own, easily distinguished from other reverberators in the pre-digital reverb era, such as springs or actual “echo” chambers. Plates were bright and diffused (built up echo density) rapidly. Curiously, when we listen to a vintage plate today, we find that the much vaunted brightness is nothing like what we can accomplish digitally; we actually have to deliberately reduce the brightness of a plate emulation to match the sound of a real plate. Similarly, we find that we must throttle back on the low frequency content as well.

FXAlg #14: Grand Plate

The algorithm developed for Grand Plate was carefully crafted for rapid diffusion, low coloration, freedom from discrete early reflections, and “brightness”. We also added some controls that were never present in real plates: size, predelay of up to 500ms, LF damping, lowpass roll off, and bass roll off. Furthermore, we allow a wider range of decay time adjustment than a conventional plate. Once the algorithm was complete, we tuned it by listening to the original EMT reverb on one channel and the Grand Plate emulation on the other. A lengthy and careful tuning of Grand Plate (tuning at the micro detail level of each delay and gain in the algorithm) was carried out until the stereo spread of this reverb was matched in all the time periods—early, middle, and late.

The heart of this reverb is the plate simulation network, with its two inputs and two outputs. It is a full stereo reverberation network, which means that the left and right inputs get slightly different treatment in the reverberator. This yields a richer, more natural stereo image from stereo sources. If you have a mono source, assign it to both inputs for best results.

The incoming left source is passed through predelay, lowpass (Lowpass), and bass-shelf (Bass Gain) blocks. The right source is treated similarly.

There are lowpass filters (HF Damping) and high pass filters (LF Damping) embedded in the plate simulation network to modify the decay times. The reverb network also accommodates the Room Size and Decay Time controls.

An output mixer assembles dry and wet signals.

Parameters:**PAGE 1**

Wet/Dry	0 to 100%wet	Out Gain	Off, -79.0 to 24.0 dB
Room Size	1.00 to 4.00 m		
Pre Dly	0 to 500 ms	Decay Time	0.2 to 5.0 s
HF Damping	16 to 25088 Hz	LF Damping	1 to 294 Hz

PAGE 2

Lowpass	16 to 25088 Hz	Bass Gain	-15 to 0 dB
----------------	-----------------------	------------------	--------------------

Wet/Dry The amount of the stereo reverberator (wet) signal relative to the original input (dry) signal sent to the output. The dry signal is not affected by the Lowpass or Bass Gain controls. The wet signal is affected by the Lowpass and Bass Gain controls and by all the other reverberator controls. The balance between wet and dry signals is an extremely important factor in achieving a good mix. Emphasizing the wet signal gives the effect of more reverberation and of greater distance from the source.

Out Gain The overall output level for the reverberation effect and controls the level for both the wet and dry signal paths.

Room Size Choosing an appropriate room size is very important in getting a good reverberation effect. For impulsive sources, such as percussion instruments or plucked strings, increase the size setting until discrete reflections become audible, and then back it off slightly. For slower, softer music, use the largest size possible. At lower settings, Room Size leads to coloration, especially if the Decay Time is set too high. To emulate a plate reverb, this control is typically set to 1.9m.

Pre Dly Introducing predelay creates a gap of silence that allows the dry signal to stand out with greater clarity and intelligibility against the reverberant background. This is especially helpful with vocals or classical music.

<u>Decay Time</u>	The reverberation decay time (mid-band “RT ₆₀ ”), the time required before the reverberation has died away to 60dB below its “running” level. Adjust decay time according to the tempo and articulation of the music. To emulate a plate reverb, this control is typically set from 1 to 5 seconds.
<u>HF Damping</u>	Adjusts lowpass filters in the reverberator so that high frequencies die away more quickly than mid and low frequencies. This shapes the reverberation for a more natural, more acoustically accurate sound. To emulate a plate reverb, this control is typically set to 5920Hz.
<u>LF Damping</u>	Adjusts hipass filters in the reverberator so that low frequencies die away more quickly than mid and high frequencies. This shapes the reverberation for a more natural, more acoustically accurate sound. To emulate a plate reverb, this control is typically set to 52 Hz.
<u>Lowpass</u>	Shapes the overall reverberation signal’s treble content, but does not modify the decay time. Reduce the treble for a duller, more natural acoustic effect. To emulate a plate reverb, this control is typically set to 3951Hz.
<u>Bass Gain</u>	Shapes the overall reverberation signal’s bass content, but does not modify the decay time. Reduce the bass for a less muddy sound. To emulate a plate reverb, this control is typically set to -12dB.

FXAlg #15: Finite Verb

“Enveloped” reverberation algorithm

Allocation Units: 3

In this algorithm, the left and right sources are summed before being fed into a tapped delay line, which directly simulates the impulse response of a reverberator. The taps are placed in sequence from zero delay to a maximum delay value, at quasi-regular spacings. By varying the coefficients with which these taps are summed, one can create the effect of a normal rapidly building/slowly decaying reverb or a reverse reverb which builds slowly then stops abruptly.

A special tap is picked off the tapped delay line and its length is controlled by Dly Length. It can be summed into the output wet mix (Dly Lvl) to serve as the simulated dry source that occurs after the reverse reverb sequence has built up and ended. It can also be fed back for special effects. Fdbk Lvl and HF Damping tailor the gain and spectrum of the feedback signal. Despite the complex reverb-like sound of the tapped delay line, the Feedback tap is a pure delay. Feeding it back is like reapplying the source, as in a simple tape echo.

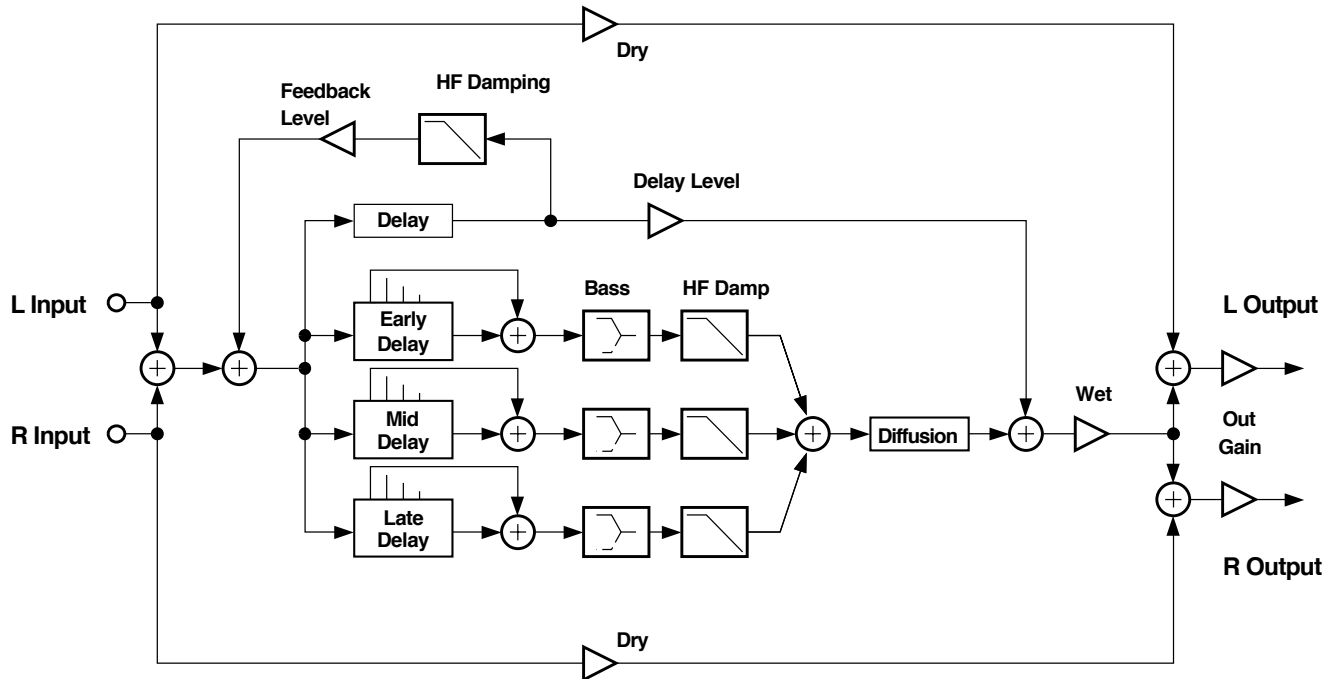

Diagram of Finite Verb

Dly Length and Rvb Length range from 300 to 3000 milliseconds. With the R1 Rvb Env variants, Rvb Length corresponds to a decay time (RT_{60}).

To make things a little more interesting, the tapped delay line mixer is actually broken into three mixers: an early, middle, and late mixer. Each mixes its share of taps and then applies the submix to a lowpass filter (cut only) and a simple bass control (boost and cut). Finally, the three equalized sub mixes are mixed into one signal. The Bass and Damp controls allow special effects such as a reverb that begins dull and increases in two steps to a brighter sound.

The Rvb Env control selects 27 cases of envelope gains for the taps. Nine cases emulate a normal forward-evolving reverb, but with some special twists. Cases FWD R1xx have a single reverb peak, with a fast attack and slower decay. The sub cases FWD R1Sx vary the sharpness of the envelope, from dullest (S1) to sharpest (S3). The sub cases FWD R2xx have two peaks; that is, the reverb builds, decays, builds again, and decays again. The sub cases FWD R3xx have three peaks.

The sub cases SYM have a symmetrical build and decay time. The cases R1 build to a single peak, while R2 and R3 have two and three peaks, respectively.

The sub cases REV simulate a reverse reverb effect. REV R1xx imitates a backward running reverb, with a long rising "tail" ending abruptly (followed, optionally, by the "dry" source mixed by Dly Lvl). Once again, the number of peaks and the sharpness are variable.

The usual Wet/Dry and Output Gain controls are provided.

Parameters:

PAGE 1

Wet/Dry	0 to 100%wet	Out Gain	Off, -79.0 to 24.0 dB
Fdbk Lvl	0 to 100%		
HF Damping	16 to 25088 Hz		

PAGE 2

Dly Lvl	0 to 100%	Rvb Env	REV R1S1
Dly Length	300 to 3000 ms	Rvb Length	300 to 3000 ms

PAGE 3

Early Bass	-15 to 15 dB	Early Damp	16 to 25088 Hz
Mid Bass	-15 to 15 dB	Mid Damp	16 to 25088 Hz
Late Bass	-15 to 15 dB	Late Damp	16 to 25088 Hz

Wet/Dry

Wet/Dry sets the relative amount of wet signal and dry signal. The wet signal consists of the reverb itself (stereo) and the delayed mono signal arriving after the reverb has ended (simulating the dry source in the reverse reverb sequence). The amount of the delayed signal mixed to the Wet signal is separately adjustable with the Dly Lvl control. The Dry signal is the stereo input signal.

Out Gain

This controls the level of the output mix, wet and dry, sent back into KDFX.

Fdbk Lvl

This controls the feedback gain of the separate (mono) delay tap. A high value contributes a long repeating echo character to the reverb sound.

HF Damping

HF Damping adjusts a lowpass filter in the late delay tap feedback path so that high frequencies die away more quickly than mid and low frequencies.

Dly Lvl

This adjusts the level of the separate (mono) delay tap used to simulate the dry source of a reverse reverb effect. This same tap is used for feedback.

Dly Length

Sets the length (in milliseconds), of the separate (mono) delay tap used to simulate the dry source of a reverse reverb effect. This same tap is used for feedback.

FXAlg #15: Finite Verb

- Rvb Env The Rvb Env control selects 27 cases of envelope gains for the taps. Nine cases emulate a normal forward evolving reverb, another nine emulate a reverb building symmetrically to a peak at the mid point, while the last nine cases emulate a reverse-building reverb. For each major shape, there are three variants of one, two, and three repetitions and three variants of envelope sharpness.
- Rvb Length Sets the length (in milliseconds), from start to finish, of the reverberation process. This parameter is essentially the decay time or RT_{60} for the Rvb Env cases..R1.. where there is only one repetition.
- Early Bass, Mid Bass, and Late Bass These bass controls shape the frequency response (boost or cut) of the three periods of the finite reverb sequence. Use them to tailor the way the reverb bass content changes with time.
- Early Damp, Mid Damp, and Late Damp These treble controls shape the frequency response (cut only) of the three periods of the finite reverb sequence. Use them to tailor the way the reverb treble content changes with time.

FXAlg #130: Complex Echo

Multitap delay line effect, consisting of 6 independent output taps
and 4 independent feedback taps

Allocation Units: 1

Complex Echo is an elaborate delay line with three independent output taps per channel, two independent feedback taps per channel, equal-power output tap panning, feedback diffuser, and high frequency damping. Each channel has three output taps which can each be delayed up to 2600ms (2.6 sec) then panned at the output. Feedback taps can also be delayed up to 2600ms, but both feedback channels do slightly different things. Feedback line 1 feeds the signal back to the delay input of the same channel, while feedback line 2 feeds the signal back to the opposite channel—it can be considered “ping-pong” feedback. Relative levels for each feedback line can be set with the “FB2/FB1>FB” control where 0% only allows FB1 to be used, and 100% only allows FB2 to be used.

The diffuser sits at the beginning of the delay line, and consists of three controls. Separate left and right Diff Dly parameters control the length that a signal is smeared from 0 to 100ms as it passes through these diffusers. Diff Amt adjusts the smearing intensity. Short diffuser delays can diffuse the sound while large delays can drastically alter the spectral flavor. Setting all three diffuser parameters to 0 will disable the diffuser.

Also at the input to the delays are 1-pole (6dB/oct) lowpass filters controlled by the HF Damping parameter.

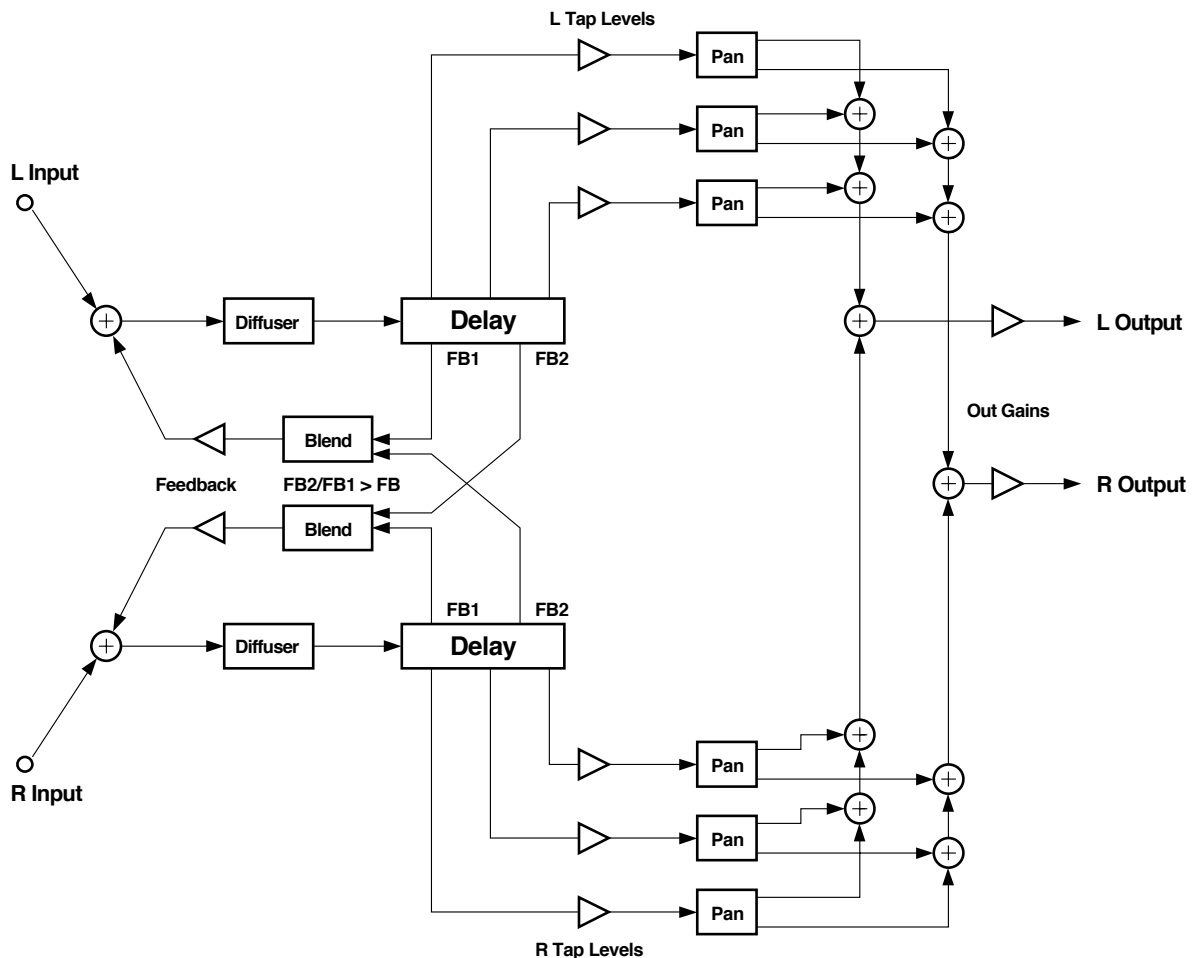

Signal flow of Complex Echo

Parameters:

PAGE 1

Wet/Dry	0 to 100%wet	Out Gain	Off, -79.0 to 24.0 dB
Feedback	0 to 100%	L Diff Dly	0 to 100 ms
FB2/FB1>FB	0 to 100%	R Diff Dly	0 to 100 ms
HF Damping	16 to 25088 Hz	Diff Amt	0 to 100%

PAGE 2

L Fdbk1 Dly	0 to 2600 ms	R Fdbk1 Dly	0 to 2600 ms
L Fdbk2 Dly	0 to 2600 ms	R Fdbk2 Dly	0 to 2600 ms
L Tap1 Dly	0 to 2600 ms	R Tap1 Dly	0 to 2600 ms
L Tap2 Dly	0 to 2600 ms	R Tap2 Dly	0 to 2600 ms
L Tap3 Dly	0 to 2600 ms	R Tap3 Dly	0 to 2600 ms

PAGE 3

L Tap1 Lvl	0 to 100%	R Tap1 Lvl	0 to 100%
L Tap2 Lvl	0 to 100%	R Tap2 Lvl	0 to 100%
L Tap3 Lvl	0 to 100%	R Tap3 Lvl	0 to 100%

PAGE 4

L Tap1 Pan	-100 to 100%	R Tap1 Pan	-100 to 100%
L Tap2 Pan	-100 to 100%	R Tap2 Pan	-100 to 100%
L Tap3 Pan	-100 to 100%	R Tap3 Pan	-100 to 100%

- Wet/Dry The relative amount of input signal and effected signal that is to appear in the final effect output mix. When set to 0%, the output is taken only from the input (dry). When set to 100%, the output is all wet.
- Out Gain The overall gain or amplitude at the output of the effect.
- Feedback The amplitude of the feedback tap(s) fed back to the beginning of the delay.
- FB2/FB1>FB Balance control between feedback line 1 and line 2. Setting this to 0% turns off feedback line 2, only allowing use of feedback line 1. A setting of 50% is an even mix of both lines, and 100% turns off line 1.
- HF Damping The amount of high frequency content of the signal to the input of the delay. This control determines the cutoff frequency of the one-pole (-6dB/octave) lowpass filters.
- L Diff Dly, R Diff Dly Adjusts delay length of the diffusers.
- Diff Amt Adjusts the diffuser intensity.
- L Fdbk1 Dly Adjusts the delay length of the left channel’s feedback tap, fed back to the left channel’s delay input.
- L Fdbk2 Dly Adjusts the delay length of the left channel’s feedback tap, fed back to the right channel’s delay input.
- R Fdbk1 Dly Adjusts the delay length of the right channel’s feedback tap, fed back to the right channel’s delay input.

<u>R Fdbk2 Dly</u>	Adjusts the delay length of the right channel's feedback tap, fed back to the left channel's delay input.
<u>L Tapn Dly, R Tapn Dly</u>	Adjusts the delay length of the left and right channel's three output taps.
<u>L Tapn Lvl, L Tapn Lvl</u>	Adjusts the listening level of the left and right channel's three output taps.
<u>L Tapn Pan, L Tapn Pan</u>	Adjusts the equal power pan position of the left and right channel's three output taps. 0% is center pan, negative values pan to left, and positive values pan to the right.

FXAlg #131: 4-Tap Delay • FXAlg #132: 4-Tap Delay BPM

A stereo four-tap delay with feedback
Allocation Units: 1

This is a simple stereo 4-tap delay algorithm with delay lengths defined either in milliseconds (ms) (#131), or in tempos and beats (#132). The left and right channels are fully symmetric (all controls affect both channels). The duration of each stereo delay tap (length of the delay) and the signal level from each stereo tap may be set. Prior to output each delay tap passes through a level and left/right balance control. The taps are summed and added to the dry input signal through a Wet/Dry control. The delayed signal from the “Loop” tap may be fed back to the delay input.

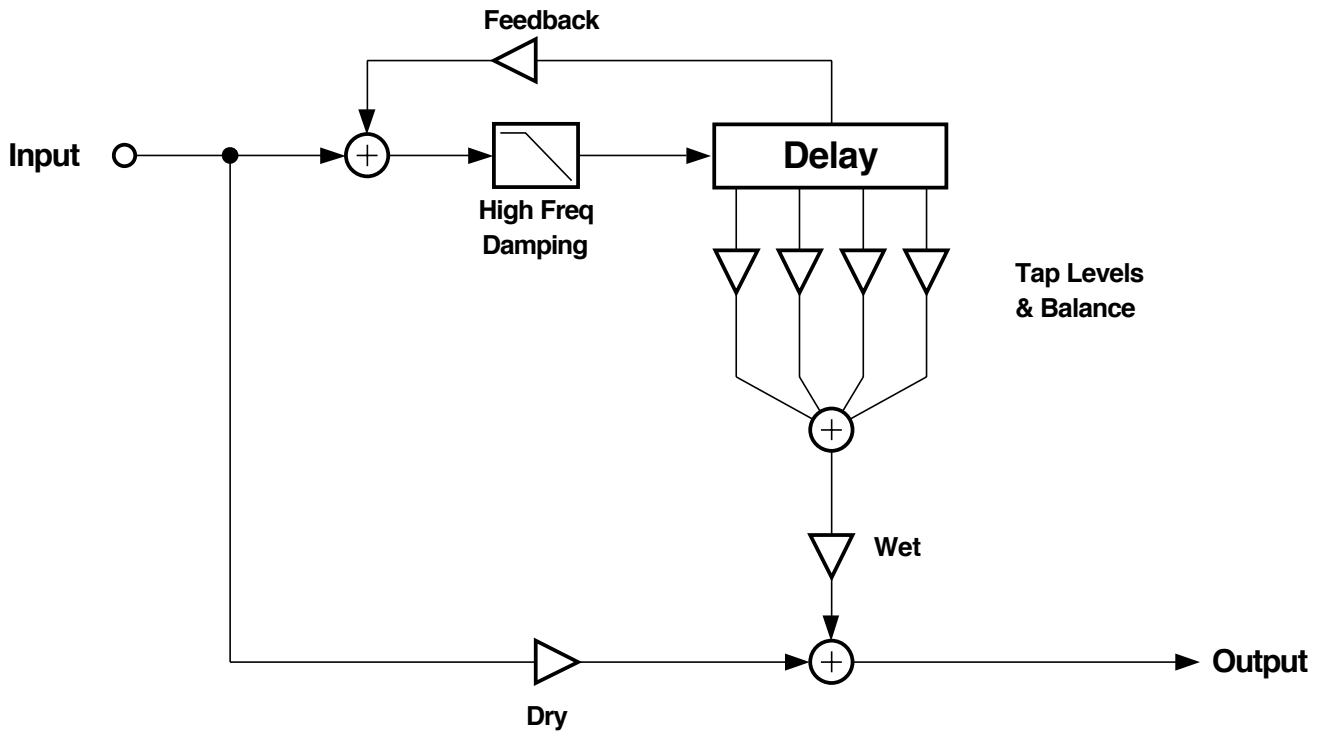

Left Channel of 4-Tap Delay

The delay length for any given tap is the sum of the coarse and fine parameters for the tap, multiplied by the DelayScale parameter which is common to all taps. The DelayScale parameter allows you to change the lengths of all the taps together.

A repetitive loop delay is created by turning up the Fdbk Level parameter. Only the Loop tap is fed back to the input of the delay, so this is the tap which controls the loop rate. Usually you will want the Loop delay length to be longer than the other tap lengths. Set the Loop delay length to the desired length, then set the other taps to fill in the measure with interesting rhythmical patterns. Setting tap levels allows some “beats” to receive more or less emphasis than others.

The delay lengths for 4-Tap Delay are in units of milliseconds (ms). If you want to base delay lengths on tempo, then the 4-Tap Delay BPM algorithm may be more convenient.

The feedback (Fdbk Level) controls how long a sound in the delay line takes to die out. At 100% feedback, the sound will be repeated indefinitely. HF Damping selectively removes high-frequency content from the delayed signal and will also cause the sound to eventually disappear.

The Hold parameter is a switch which controls signal routing. When turned on, Hold will play whatever signal is in the delay line indefinitely. Hold overrides the feedback parameter and prevents any incoming signal from entering the delay. You may have to practice using the Hold parameter. Each time the sound goes through the delay, it is reduced by the feedback amount. If feedback is fairly low and you turn on Hold at the wrong moment, you can get a disconcerting jump in level at some point in the loop. The Hold parameter has no effect on the Wet/Dry or HF Damping parameters, which continue to work as usual, so if there is some HF Damping, the delay will eventually die out.

Parameters:

PAGE 1

Wet/Dry	0 to 100%wet	Out Gain	Off, -79.0 to 24.0 dB
Fdbk Level	0 to 100%		
		Dry Bal	-100 to 100%
HF Damping	16 Hz to 25088 Hz	Hold	On or Off

PAGE 2

Loop Crs	0 to 2540 ms	DelayScale	0.00x to 10.00x
Loop Fine	-20 to 20 ms		
Tap1 Crs	0 to 2540 ms	Tap3 Crs	0 to 2540 ms
Tap1 Fine	-20 to 20 ms	Tap3 Fine	-20 to 20 ms
Tap2 Crs	0 to 2540 ms	Tap4 Crs	0 to 2540 ms
Tap2 Fine	-20 to 20 ms	Tap4 Fine	-20 to 20 ms

PAGE 3

Loop Level	0 to 100%	Loop Bal	-100 to 100%
Tap2 Level	0 to 100%	Tap2 Bal	-100 to 100%
Tap3 Level	0 to 100%	Tap3 Bal	-100 to 100%
Tap4 Level	0 to 100%	Tap4 Bal	-100 to 100%

Wet/Dry

The relative amount of input signal and delay signal that are to appear in the final effect output mix. When set to 0%, the output is taken only from the input (dry). When set to 100%, the output is all wet.

Out Gain

The overall gain or amplitude at the output of the effect.

Fdbk Level

The percentage of the delayed signal to feed back or return to the delay input. Turning up the feedback will cause the effect to repeatedly echo or act as a crude reverb.

HF Damping

The -3 dB frequency in Hz of a one-pole lowpass filter (-6 dB/octave) placed in front of the delay line. The filter is specified for a signal passing through the filter once. Multiple passes through the feedback will cause the signal to become more and more dull.

FXAlg #131: 4-Tap Delay • FXAlg #132: 4-Tap Delay BPM

<u>Dry Bal</u>	The left-right balance of the dry signal. A setting of -100% allows only the left dry signal to pass to the left output, while a setting of 100% lets only the right dry signal pass to the right output. At 0%, equal amounts of the left and right dry signals pass to their respective outputs.
<u>Hold</u>	A switch which when turned on, locks any signal currently in the delay to play until Hold is turned off. When Hold is on, no signal can enter the delay and Feedback is set to 100% behind the scenes. Hold does not affect the HF Damping or Wet/Dry mix. A good candidate for a KDFX FXMod mapped to a momentary foot switch.
<u>Tapn Level</u>	The amount of signal from each of the taps ($n = 1...4$) which get sent to the output. With the Loop Lvl control, you can give different amounts of emphasis to the various taps in the loop.
<u>Tapn Bal</u>	The left-right balance of each of the stereo taps ($n = 1...4$). A setting of -100% allows only the left tap to pass to the left output, while a setting of 100% lets only the right tap pass to the right output. At 0%, equal amounts of the left and right taps pass to their respective outputs.

The following parameters are in #131 4-Tap Delay only:

<u>Loop Crs</u>	The coarse delay length of the Loop tap. If the feedback is turned up, this parameter sets the repeating delay loop length. The resolution of the coarse adjust is 20 milliseconds, but finer resolution can be obtained using the Loop Fine parameter. The maximum delay length is 2.55 seconds (2550ms).
<u>Loop Fine</u>	A fine adjustment to the Loop tap delay length. The delay resolution is 0.2 milliseconds (ms). Loop Fine is added to Loop Crs (coarse) to get the actual delay length.
<u>Delay Scale</u>	Multiplies all tap times by a common factor.
<u>Tapn Crs</u>	The coarse delay lengths of the output taps ($n = 1...4$). The resolution of the coarse adjust is 20 milliseconds, but finer resolution can be obtained using the Tap n Fine parameters. The maximum delay length is 2.55 seconds (2550ms).
<u>Tapn Fine</u>	A fine adjustment to the output tap delay lengths ($n = 1...4$). The delay resolution is 0.2 milliseconds (ms). Tap n Fine is added to Tap n Crs (coarse) to get actual delay lengths.

FXAlg #132: 4-Tap Delay BPM

In this Algorithm, the delay length for any given tap is determined by the tempo, expressed in beats per minute (BPM), and multiples or fractions of beats (bts). The tempo alters all tap lengths together.

The “bts” parameter is adjustable in increments of 1/24th of a beat, which is a useful fraction because it can divide beats into 2, 3, 4, 6, 8, or 12 parts. The length of a delay in seconds can be calculated as $T = (\text{beats} / \text{tempo}) * 60$.

IMPORTANT NOTE: KDFX has a limited amount of delay memory available (over 2.5 seconds for 4-Tap BPM). When slow tempos and/or long lengths are specified, you may run out of delay memory, at which point the delay length will be cut in half. When you slow down the tempo, you may find the delays suddenly getting shorter.

A repetitive loop delay is created by turning up the feedback parameter (Fdbk Level). Only the Loop tap is fed back to the input of the delay, so this is the tap which controls the loop rate. Usually you will want the Loop tap (LoopLength parameter) to be longer than the other tap lengths. To repeat a pattern on a 4/4 measure (4 beats per measure) simply set LoopLength to 4 bts. The output taps can then be used to fill in the measure with interesting rhythmical patterns. Setting tap levels allows some “beats” to receive more or less emphasis than others.

Parameters:

PAGE 1

Wet/Dry	0 to 100%wet	Out Gain	Off, -79.0 to 24.0 dB
Fdbk Level	0 to 100%	Tempo	System, 1 to 255 BPM
		Dry Bal	-100 to 100%
HF Damping	16 Hz to 25088 Hz	Hold	On or Off

PAGE 2

LoopLength	0 to 32 bts		
Tap1 Delay	0 to 32 bts		
Tap2 Delay	0 to 32 bts		
Tap3 Delay	0 to 32 bts		
Tap4 Delay	0 to 32 bts		

PAGE 3

Tap1 Level	0 to 100%	Tap1 Bal	-100 to 100%
Tap2 Level	0 to 100%	Tap2 Bal	-100 to 100%
Tap3 Level	0 to 100%	Tap3 Bal	-100 to 100%
Tap4 Level	0 to 100%	Tap4 Bal	-100 to 100%

Tempo Basis for the delay lengths, as referenced to a musical tempo in bpm (beats per minute). When this parameter is set to "System", the tempo is locked to the internal sequencer tempo or to incoming MIDI clocks. When it is set to "System", sources (FUNs, LFOs, ASRs etc.) will have no effect on the Tempo parameter.

LoopLength The delay length of the Loop tap. If the feedback is turned up, this parameter sets the repeating delay loop length. The loop length is specified as a fraction or multiple of the tempo, in "beats". The length of a delay loop in seconds can be calculated as $T = (\text{beats}/\text{tempo}) * 60$.

Tap n Delay The delay lengths of the taps ($n = 1..4$). as tempo beat durations. The delay length is specified as a fraction or multiple of the tempo, in "beats". The length of a delay in seconds can be calculated as $T = (\text{beats}/\text{tempo}) * 60$. Use the output taps to create interesting rhythmic patterns within the repeating loop.

FXAlg #133: 8-Tap Delay • FXAlg #134: 8-Tap Delay BPM

A stereo eight-tap delay with cross-coupled feedback
Allocation Units: 2

This is a simple stereo 8-tap delay algorithm with delay lengths defined in milliseconds (ms) (#133), or in tempos and beats (#134). The left and right channels are fully symmetric (all controls affect both channels). The duration of each stereo delay tap (length of the delay) and the signal level from each stereo tap may be set. Prior to output each delay tap passes through a level and left/right balance control. Pairs of stereo taps are tied together with balance controls acting with opposite left/right sense. The taps are summed and added to the dry input signal through a Wet/Dry control. The delayed signal from the “Loop” tap may be fed back to the delay input. The sum of the input signal and the feedback signal may be mixed or swapped with the input/feedback signal from the other channel (cross-coupling). When used with feedback, cross-coupling can achieve a ping-pong effect between the left and right channels.

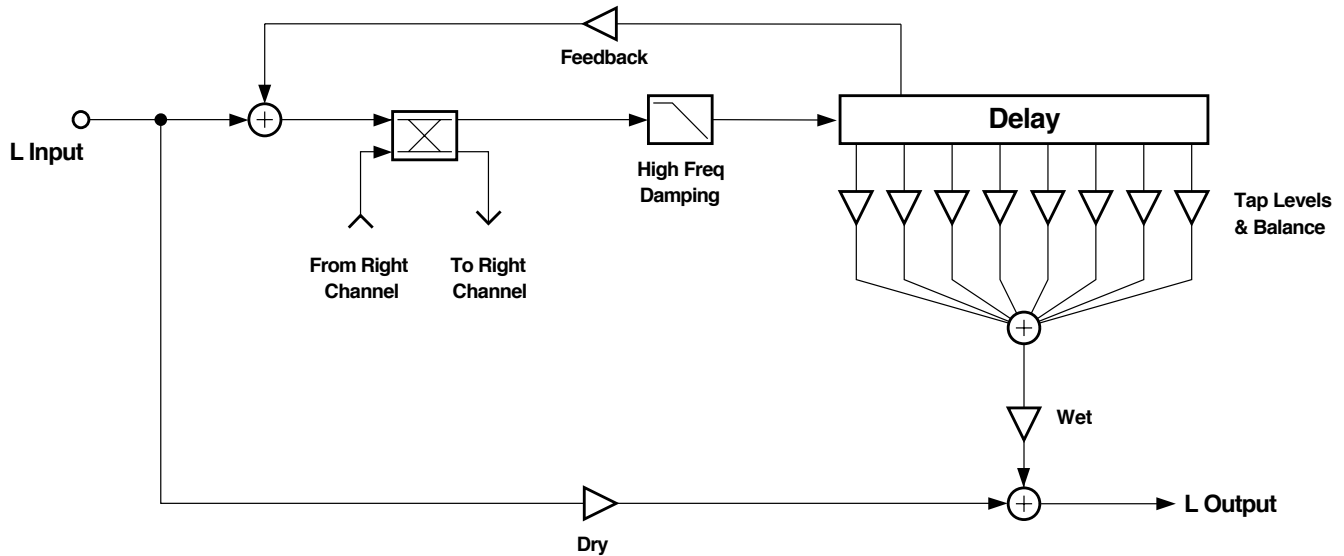

Left Channel of 8-Tap Delay

The delay length for any given tap is the sum of the coarse and fine parameters for the tap multiplied by the DelayScale parameter which is common to all taps. The DelayScale parameter allows you to change the lengths of all the taps together.

A repetitive loop delay is created by turning up the Fdbk Level parameter. Only the Loop tap is fed back to the input of the delay, so this is the tap which controls the loop rate. Usually you will want the Loop delay length to be longer than the other tap lengths. Set the Loop delay length to the desired length, then set the other taps to fill in the measure with interesting rhythmical patterns. Setting tap levels allows some “beats” to receive more or less emphasis than others.

The delay lengths for 8-Tap Delay are in milliseconds (ms). If you want to base delay lengths on tempo, then the 8-Tap Delay BPM algorithm may be more convenient.

The feedback (Fdbk Level) controls how long a sound in the delay line takes to die out. At 100% feedback, the sound will be repeated indefinitely. HF Damping selectively removes high-frequency content from the delayed signal and will also cause the sound to eventually disappear.

The Hold parameter is a switch which controls signal routing. When turned on, Hold will play whatever signal is in the delay line indefinitely. Hold overrides the feedback parameter and prevents any incoming signal from entering the delay. You may have to practice using the Hold parameter. Each time the sound goes through the delay, it is reduced by the feedback amount. If feedback is fairly low and you turn on Hold at the wrong moment, you can get a disconcerting jump in level at some point in the loop. The Hold parameter has no effect on the Wet/Dry or HF Damping parameters, which continue to work as usual, so if there is some HF Damping, the delay will eventually die out. It is an excellent candidate for a KDFX Modulation routing using a momentary foot switch as a source.

Parameters:

PAGE 1

Wet/Dry	0 to 100%wet	Out Gain	Off, -79.0 to 24.0 dB
Fdbk Level	0 to 100%		
Xcouple	0 to 100%	Dry Bal	-100 to 100%
HF Damping	16 Hz to 25088 Hz	Hold	On or Off

PAGE 2

Loop Crs	0 to 5100 ms	DelayScale	0.00x to 10.00x
Loop Fine	-20 to 20 ms		
Tap1 Crs	0 to 5100 ms	Tap3 Crs	0 to 5100 ms
Tap1 Fine	-20 to 20 ms	Tap3 Fine	-20 to 20 ms
Tap2 Crs	0 to 5100 ms	Tap4 Crs	0 to 5100 ms
Tap2 Fine	-20 to 20 ms	Tap4 Fine	-20 to 20 ms

PAGE 3

Tap5 Crs	0 to 5100 ms	Tap7 Crs	0 to 5100 ms
Tap5 Fine	-20 to 20 ms	Tap7 Fine	-20 to 20 ms
Tap6 Crs	0 to 5100 ms	Tap8 Crs	0 to 5100 ms
Tap6 Fine	-20 to 20 ms	Tap8 Fine	-20 to 20 ms

PAGE 4

Tap1 Level	0 to 100%	Tap5 Level	0 to 100%
Tap2 Level	0 to 100%	Tap6 Level	0 to 100%
Tap3 Level	0 to 100%	Tap7 Level	0 to 100%
Tap4 Level	0 to 100%	Tap8 Level	0 to 100%
Tap1/-5Bal	-100 to 100%	Tap3/-7Bal	-100 to 100%
Tap2/-6Bal	-100 to 100%	Tap4/-8Bal	-100 to 100%

Wet/Dry

The relative amount of input signal and delay signal that is to appear in the final effect output mix. When set to 0%, the output is taken only from the input (dry). When set to 100%, the output is all wet.

Out Gain

The overall gain or amplitude at the output of the effect.

Fdbk Level

The percentage of the delayed signal to feed back or return to the delay input. Turning up the feedback will cause the effect to repeatedly echo or act as a crude reverb.

FXAlg #133: 8-Tap Delay • FXAlg #134: 8-Tap Delay BPM

<u>Xcouple</u>	8-Tap Delay is a stereo effect. The cross-coupling control lets you send the feedback from a channel to its own input (0% cross-coupling) or to the other channel's input (100% cross-coupling) or somewhere in between. This control has no effect if the Fdbk Level control is set to 0%.
<u>HF Damping</u>	The -3 dB frequency in Hz of a one-pole lowpass filter (-6 dB/octave) placed in front of the delay line. The filter is specified for a signal passing through the filter once. Multiple passes through the feedback will cause the signal to become more and more dull.
<u>Dry Bal</u>	The left/right balance of the dry signal. A setting of -100% allows only the left dry signal to pass to the left output, while a setting of 100% lets only the right dry signal pass to the right output. At 0%, equal amounts of the left and right dry signals pass to their respective outputs.
<u>Hold</u>	A switch which when turned on, locks any signal currently in the delay to play until Hold is turned off. When Hold is on, no signal can enter the delay and Feedback is set to 100% behind the scenes. Hold does not affect the HF Damping or Wet/Dry mix. It is an excellent candidate for a KDFX Modulation routing using a momentary foot switch as a source.
<u>Tapn Level</u>	The amount of signal from each of the taps ($n = 1...8$) which gets sent to the output.
<u>Tapm / -n Bal</u>	The left/right balance of each of the stereo taps. The balances are controlled in pairs of taps: 1 & 5, 2 & 6, 3 & 7, and 4 & 8. The balance controls work in opposite directions for the two taps in the pair. When the balance is set to -100%, the first tap of the pair is fully right while the second is fully left. At 0%, equal amounts of the left and right taps pass to their respective outputs.

The following parameters are in #133 8-Tap Delay only:

<u>Loop Crs</u>	The coarse delay length of the Loop tap. If the feedback is turned up, this parameter sets the repeating delay loop length. The resolution of the coarse adjust is 20 milliseconds, but finer resolution can be obtained using the Loop Fine parameter. The maximum delay length is 5.10 seconds (5100ms).
<u>Loop Fine</u>	A fine adjustment to the Loop tap delay length. The delay resolution is 0.2 milliseconds (ms). Loop Fine is added to Loop Crs (coarse) to get the actual delay length.
<u>Delay Scale</u>	Multiplies all tap times by a common factor.
<u>Tapn Crs</u>	The coarse delay lengths of the output taps ($n = 1...8$). The resolution of the coarse adjust is 20 milliseconds, but finer resolution can be obtained using the Tap n Fine parameters. The maximum delay length is 5.1 seconds (5100ms).
<u>Tapn Fine</u>	A fine adjustment to the output tap delay lengths ($n = 1...8$). The delay resolution is 0.2 milliseconds (ms). Tap n Fine is added to Tap n Crs (coarse) to get actual delay lengths.

FXAlg #134: 8-Tap Delay BPM

In this Algorithm, the delay length for any given tap is determined by the tempo, expressed in beats per minute (BPM), and multiples or fractions of beats (bts). The tempo alters all tap lengths together.

The “bts” parameter is adjustable in increments of 1/24th of a beat, which is a useful fraction because it can divide beats into 2, 3, 4, 6, 8, or 12 parts. The length of a delay in seconds can be calculated as $T = (\text{beats}/\text{tempo}) * 60$.

IMPORTANT NOTE: KDFX has a limited amount of delay memory available (over 5 seconds for 8-Tap BPM). When slow tempos and/or long lengths are specified, you may run out of delay memory, at which point the delay length will be cut in half. When you slow down the tempo, you may find the delays suddenly getting shorter.

A repetitive loop delay is created by turning up the feedback parameter (Fdbk Level). Only the Loop tap is fed back to the input of the delay, so this is the tap which controls the loop rate. Usually you will want the Loop tap (LoopLength parameter) to be longer than the other tap lengths. To repeat a pattern on a 4/4 measure (4 beats per measure) simply set LoopLength to 4 bts. The output taps can then be used to fill in the measure with interesting rhythmical patterns. Setting tap levels allows some “beats” to receive more or less emphasis than others.

Parameters:

PAGE 1

Wet/Dry	0 to 100%wet	Out Gain	Off, -79.0 to 24.0 dB
Fdbk Level	0 to 100%	Tempo	System, 1 to 255 BPM
Xcouple	0 to 100%	Dry Bal	-100 to 100%
HF Damping	16 Hz to 25088 Hz	Hold	On or Off

PAGE 2

LoopLength	0 to 32 bts		
Tap1 Delay	0 to 32 bts	Tap5 Delay	0 to 32 bts
Tap2 Delay	0 to 32 bts	Tap6 Delay	0 to 32 bts
Tap3 Delay	0 to 32 bts	Tap7 Delay	0 to 32 bts
Tap4 Delay	0 to 32 bts	Tap8 Delay	0 to 32 bts

PAGE 3

Tap1 Level	0 to 100%	Tap5 Level	0 to 100%
Tap2 Level	0 to 100%	Tap6 Level	0 to 100%
Tap3 Level	0 to 100%	Tap7 Level	0 to 100%
Tap4 Level	0 to 100%	Tap8 Level	0 to 100%

PAGE 4

Tap1 Bal	-100 to 100%	Tap5 Bal	-100 to 100%
Tap2 Bal	-100 to 100%	Tap6 Bal	-100 to 100%
Tap3 Bal	-100 to 100%	Tap7 Bal	-100 to 100%
Tap4 Bal	-100 to 100%	Tap8 Bal	-100 to 100%

Tempo

Basis for the delay lengths, as referenced to a musical tempo in bpm (beats per minute). When this parameter is set to “System”, the tempo is locked to the internal sequencer tempo or to incoming MIDI clocks. When it is set to “System”, sources (FUNs, LFOs, ASRs etc.) will have no effect on the Tempo parameter.

LoopLength

The delay length of the Loop tap. If the feedback is turned up, this parameter sets the repeating delay loop length. The loop length is specified as a fraction or multiple of the tempo, in “beats”. The length of a delay loop in seconds can be calculated as $T = (\text{beats}/\text{tempo}) * 60$.

Tap n Delay

The delay lengths of the taps ($n = 1..4$). as tempo beat durations. The delay length is specified as a fraction or multiple of the tempo, in “beats”. The length of a delay in seconds can be calculated as $T = (\text{beats}/\text{tempo}) * 60$. Use the output taps to create interesting rhythmic patterns within the repeating loop.

FXAlg #135: Spectral 4-Tap · FXAlg #136: Spectral 6-Tap

Tempo based 4- and 6-tap delays with
added shapers and resonant comb filters on each tap
Allocation Units: 2 for Spectral 4-Tap; 3 for Spectral 6-Tap

Spectral 4 Tap and Spectral 6 Tap are respectively 2- and 3-PAU tempo-based multi-tap delay effects. They are similar to simple 4- and 6-tap delays with feedback, but have their feedback and output taps modified with shapers and filters. In the feedback path of each channel are a diffuser, hipass filter, lowpass filter, and imager. Each delay tap has a shaper, comb filter, balance and level controls with the exception of Tap 1, which does not have a comb filter.

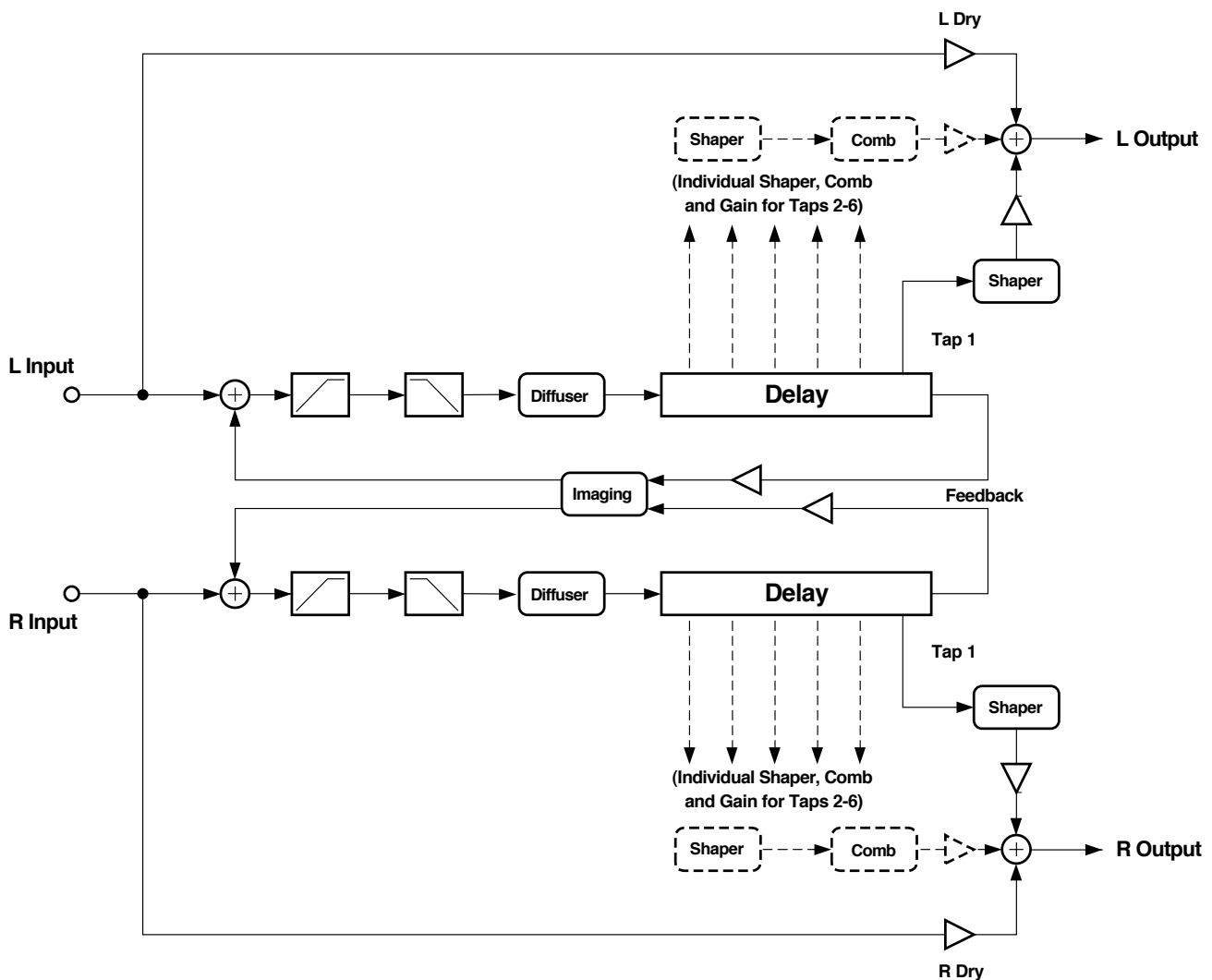

Spectral 6-Tap

Diffusers add a quality that can be described as “smearing” the feedback signal. The more a signal has been regenerated through feedback and consequently fed through the diffuser, the more it is smeared. It requires two parameters, one for the duration a signal is smeared, labeled Diff Delay, and the other for the amount it is smeared, labeled Diff Amt. Positive diffusion settings will add diffusion while maintaining image integrity. Negative diffusion amounts will cause the feedback image to lose image integrity and become wide. Short Diff Delay settings have subtle smearing effects. Increasing Diff Delay will be more noticeable, and long delay settings will take on a ringy resonant quality. To disable the diffuser, both Diff Delay and Diff Amt should be set to zero.

Two 1-pole 6dB/oct filters—hipass and lowpass—are also in the feedback path. The hipass filter roll-off frequency is controlled with LF Damping, and the lowpass filter roll-off frequency is controlled by HF Damping.

The imager (found on PARAM2) shifts the stereo input image when fed through feedback. Small positive or negative values shift the image to the right or left respectively. Larger values shift the image so much that the image gets scrambled through each feedback generation.

On each output tap is a shaper. For an overview of shaper functionality, refer to the section on shapers in the *K2500 Performance Guide*. The Spectral Multi-Tap shapers offer 4 shaping loops as opposed to 8 found in the VAST shapers, but can allow up to 6.00x intensity (Figure 2). Immediately following the shapers on taps 2 and above are resonant comb filters tuned in semitones. These comb filters make the taps become pitched. When a comb filter is in use, the shaper before it can be used to intensify these pitched qualities.

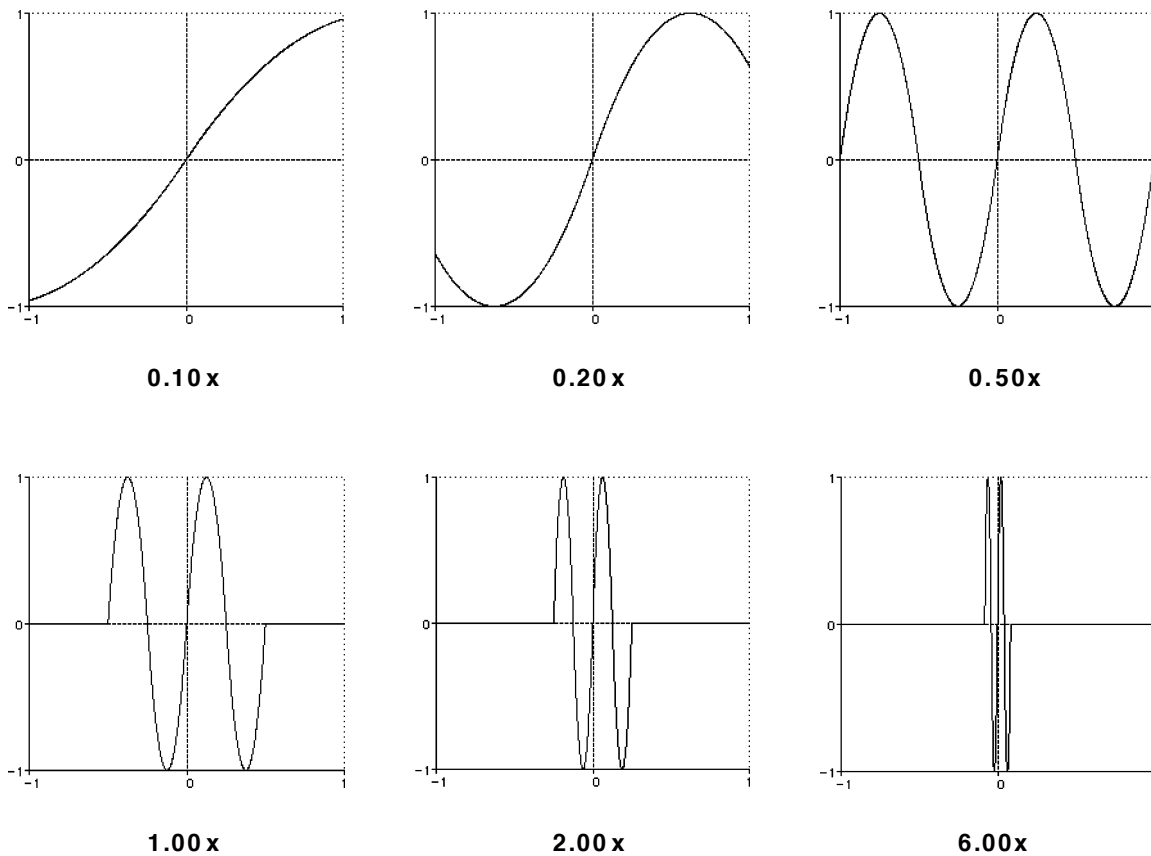

Various shaper curves used in the Spectral Multi-Taps

FXAlg #135: Spectral 4-Tap · FXAlg #136: Spectral 6-Tap

Each tap also has separate balance and level controls.

Since these are tempo based effects, tap delay values and feedback delay (labeled LoopLength on PARAM2) values are set relative to a beat. The beat duration is set by adjusting Tempo in BPM. The tempo can be synced to the system clock by setting Tempo to System.

The “bts” parameter is adjustable in increments of 1/24th of a beat, which is a useful fraction because it can divide beats into 2, 3, 4, 6, 8, or 12 parts. The length of a delay in seconds can be calculated as $T = (\text{beats} / \text{tempo}) * 60$.

Parameters (Spectral 4-Tap):**PAGE 1**

Wet/Dry	0 to 100%	Out Gain	Off, -79.0 to 24.0 dB
Fdbk Level	0 to 100%	Tempo	System, 0 to 255 BPM
HF Damping	16 to 25088 Hz	Diff Delay	0 to 20.0 ms
LF Damping	16 to 25088 Hz	Diff Amt	-100 to 100%

PAGE 2

LoopLength	On or Off	Tap2 Delay	0 to 32 bts
Fdbk Image	-100 to 100%	Tap2 Shapr	0.10 to 6.00 x
Tap1 Delay	0 to 32 bts	Tap2 Pitch	C-1 to C8
Tap1 Shapr	0.10 to 6.00 x	Tap2 PtAmt	0 to 100%
Tap1 Level	0 to 100%	Tap2 Level	0 to 100%
Tap1 Bal	-100 to 100%	Tap2 Bal	-100 to 100%

PAGE 3

Tap3 Delay	0 to 32 bts	Tap4 Delay	0 to 32 bts
Tap3 Shapr	0.10 to 6.00 x	Tap4 Shapr	0.10 to 6.00 x
Tap3 Pitch	C-1 to C8	Tap4 Pitch	C-1 to C8
Tap3 PtAmt	0 to 100%	Tap4 PtAmt	0 to 100%
Tap3 Level	0 to 100%	Tap4 Level	0 to 100%
Tap3 Bal	-100 to 100%	Tap4 Bal	-100 to 100%

Parameters (Spectral 6-Tap):**PAGE 1**

Wet/Dry	0 to 100%	Out Gain	Off, -79.0 to 24.0 dB
Fdbk Level	0 to 100%	Tempo	System, 0 to 255 BPM
HF Damping	16 to 25088 Hz	Diff Delay	0 to 20.0 ms
LF Damping	16 to 25088 Hz	Diff Amt	-100 to 100%

PAGE 2

LoopLength	On or Off	Tap2 Delay	0 to 32 bts
Fdbk Image	-100 to 100%	Tap2 Shapr	0.10 to 6.00 x
Tap1 Delay	0 to 32 bts	Tap2 Pitch	C-1 to C8
Tap1 Shapr	0.10 to 6.00 x	Tap2 PtAmt	0 to 100%
Tap1 Level	0 to 100%	Tap2 Level	0 to 100%
Tap1 Bal	-100 to 100%	Tap2 Bal	-100 to 100%

PAGE 3

Tap3 Delay	0 to 32 bts	Tap4 Delay	0 to 32 bts
Tap3 Shapr	0.10 to 6.00 x	Tap4 Shapr	0.10 to 6.00 x
Tap3 Pitch	C-1 to C8	Tap4 Pitch	C-1 to C8
Tap3 PtAmt	0 to 100%	Tap4 PtAmt	0 to 100%
Tap3 Level	0 to 100%	Tap4 Level	0 to 100%
Tap3 Bal	-100 to 100%	Tap4 Bal	-100 to 100%

PAGE 4

Tap5 Delay	0 to 32 bts	Tap6 Delay	0 to 32 bts
Tap5 Shapr	0.10 to 6.00 x	Tap6 Shapr	0.10 to 6.00 x
Tap5 Pitch	C-1 to C8	Tap6 Pitch	C-1 to C8
Tap5 PtAmt	0 to 100%	Tap6 PtAmt	0 to 100%
Tap5 Level	0 to 100%	Tap6 Level	0 to 100%
Tap5 Bal	-100 to 100%	Tap6 Bal	-100 to 100%

Wet/Dry

The relative amount of input signal and effected signal that is to appear in the final effect output mix. When set to 0%, the output is taken only from the input (dry). When set to 100%, the output is all wet. Negative values polarity-invert the wet signal.

Out Gain

The overall gain or amplitude at the output of the effect.

Fdbk Level

The amount that the feedback tap is fed to the input of the delay.

HF Damping

The amount of high-frequency content of the signal to the input of the delay. This control determines the cutoff frequency of the one-pole (-6dB/octave) lowpass filters.

LF Damping

The amount of low-frequency content of the signal to the input of the delay. This control determines the cutoff frequency of the one-pole (-6dB/octave) hipass filters.

Tempo

Basis for the rates of the delay times, as referenced to a musical tempo in BPM (beats per minute). When this parameter is set to "System", the tempo is locked to the internal sequencer tempo or to incoming MIDI clocks. When it is set to "System", sources (FUNs, LFOs, ASRs etc.) will have no effect on the Tempo parameter.

Diff Dly

The length that the diffuser smears the signal sent to the input of the delay.

Diff Amt

The intensity that the diffuser smears the signal sent to the input of the delay. Negative values decorrelate the stereo signal.

LoopLength

The delay length of the feedback tap in 24ths of a beat. The length of a delay in seconds can be calculated as $T = (\text{beats}/\text{tempo}) * 60$.

FXAlg #135: Spectral 4-Tap · FXAlg #136: Spectral 6-Tap

<u>Fdbk Image</u>	Sets the amount the stereo image is shifted each time it passes through the feedback line.
<u>Tap <i>n</i> Delay</u>	Adjusts the length of time, in 1/24ths of a beat, each output tap is delayed.
<u>Tap <i>n</i> Shapr</u>	Adjusts the intensity of the shaper at each output tap.
<u>Tap <i>n</i> Pitch</u>	Adjusts the frequency in semitones of the comb filter at each output tap.
<u>Tap <i>n</i> PtAmt</u>	Adjusts the intensity of the comb filter at each output tap.
<u>Tap <i>n</i> Level</u>	Adjusts the relative amplitude of each output tap.
<u>Tap <i>n</i> Bal</u>	Adjusts the left/right balance of each output tap. Negative values bring down the right channel, and positive values bring down the left channel.

FXAlgs #150–153: Choruses

FXAlg #150: Chorus 1

FXAlg #151: Chorus 2

FXAlg #152: Dual Chorus 1

FXAlg #153: Dual Chorus 2

One- and three-tap stereo and dual-mono choruses

Allocation Units: 1 for Chorus 1 and Dual Chorus 1; 2 for Chorus 2 and Dual Chorus 2

Chorus is an effect which gives the illusion of multiple voices playing in unison. The effect is achieved by detuning copies of the original signal and summing the detuned copies back with the original. Low-frequency oscillators (LFOs) are used to modulate the positions of output taps from a delay line. The delay line tap modulation causes the pitch of the signal to shift up and down, producing the required detuning.

The choruses are available as stereo or dual mono. The stereo choruses have the parameters for the left and right channels ganged.

Chorus 2 is a 2-PAU multi-tapped delay (3 taps) based chorus effect with cross-coupling and individual output tap panning. Figure 1 is a simplified block diagram of the left channel of Chorus 2.

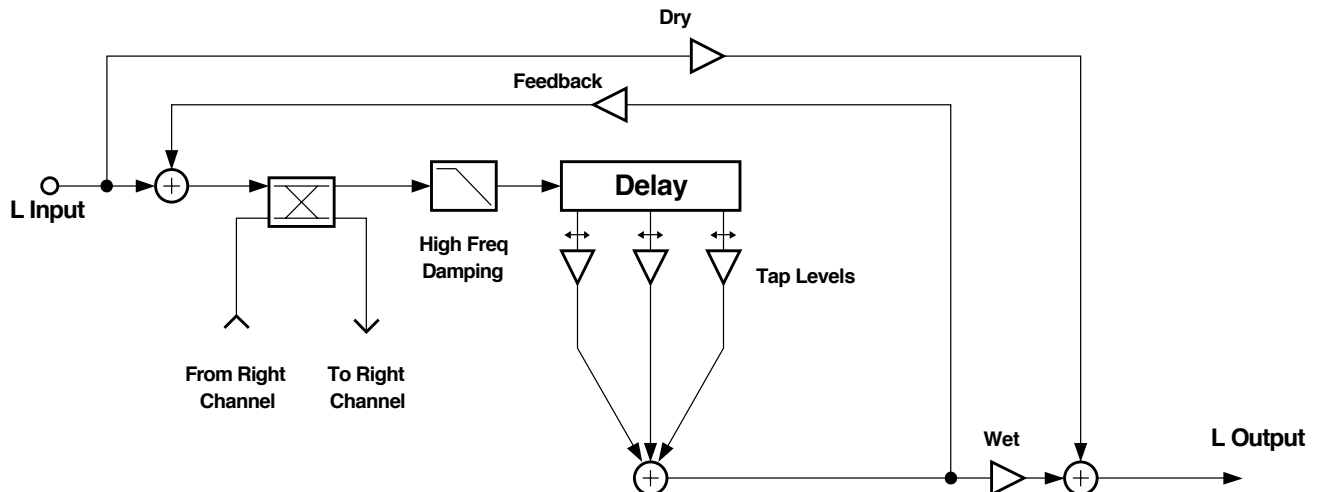

Block diagram of left channel of Chorus 2. Right channel is the same.

FXAlgs #150–153: Choruses

The dual mono choruses are like the stereo choruses but have separate left and right controls. Dual mono choruses also allow you to pan the delay taps between left or right outputs.

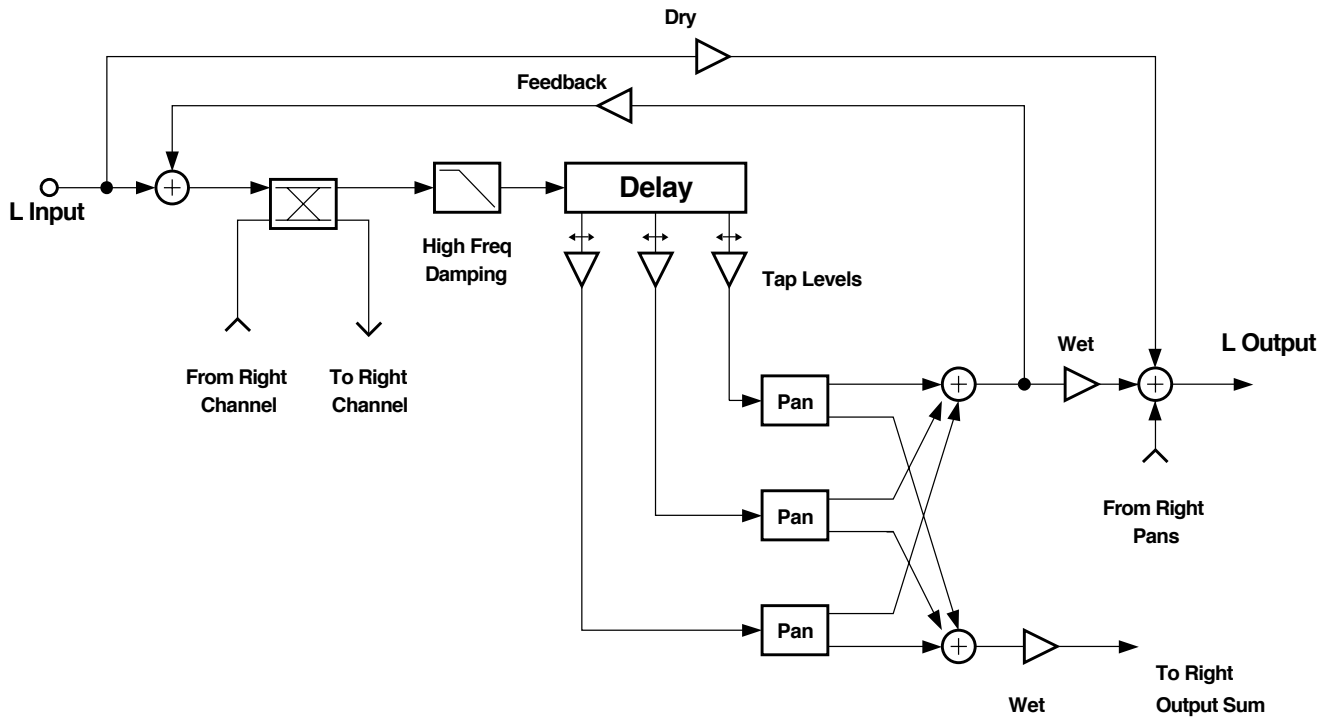

Block diagram of left channel of Dual Chorus 2. Right channel is similar.

Chorus 1 uses just 1 PAU and has a single delay tap.

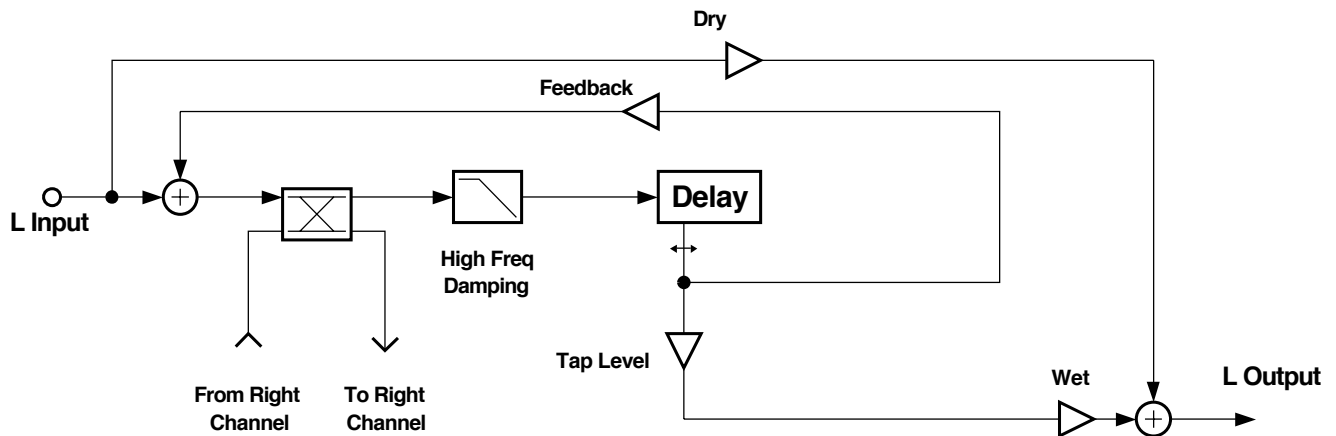

Block diagram of left channel of Chorus 1. Right channel is the same.

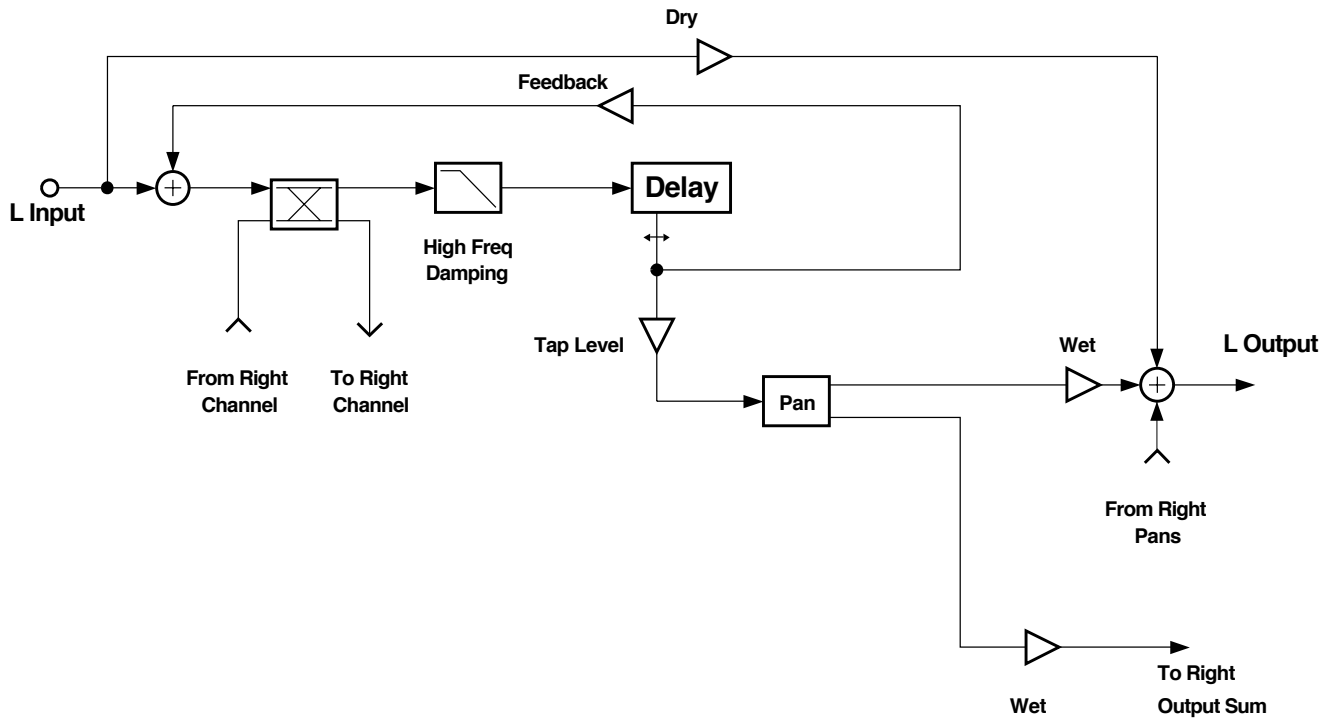

Block diagram of left channel of Dual Chorus 1. Right channel is similar.

The left and right channels pass through their own chorus blocks. There may be cross-coupling between the channels. For Chorus 2 and Dual Chorus 2, each channel has three moving taps which are summed, while Chorus 1 and Dual Chorus 1 have one moving tap for both channels. In the dual mono choruses you can pan the taps to left or right. The summed taps (or the single tap of Chorus 1) is used for the wet output signal. The summed tap outputs, weighted by their level controls, are used for feedback to the delay line input. The input and feedback signals go through a one-pole lowpass filter (HF Damping) before entering the delay line.

The Wet/Dry control is an equal power cross-fade. The Output Gain parameters affect both wet and dry signals.

For each of the LFO tapped delay lines, you may set the tap levels, the left/right pan position, delays of the modulating delay lines, the rates of the LFO cycles, and the maximum depths of the pitch detuning. The LFOs detune the pitch of signal copies above and below the original pitch. The depth units are in cents, or 1/100ths of a semitone.

In the stereo Chorus 1 and Chorus 2, the relative phases of the LFOs modulating the left and right channels may be adjusted.

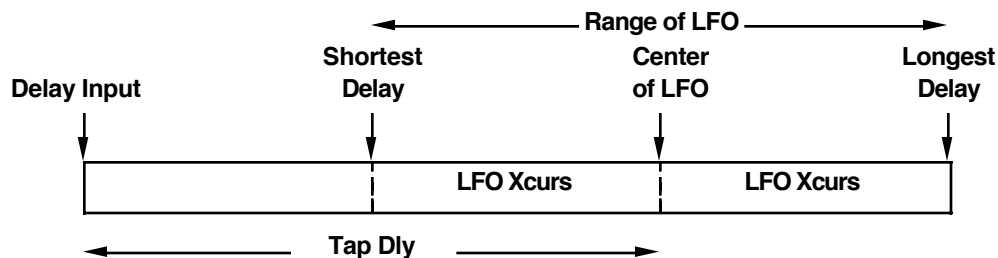

Delay for a Single LFO

The settings of the LFO rates and the LFO depths determine how far the LFOs will sweep across their delay lines from the shortest delays to the longest delays (the LFO excursions). The Tap Delays specify the average amount of delay of the LFO-modulated delay lines—in other words, the timing of the center of the LFO excursion. The center of LFO excursion can not move smoothly, and changing that parameter creates discontinuities in the tapped signal, which is heard as zipper noise. It is therefore a good idea to adjust the Tap Dly parameter to a reasonable setting (one which gives enough delay for the maximum LFO excursion), then leave it. If you increase the LFO modulation depth or reduce the LFO rate to a point where the LFO excursion exceeds the specified Tap Dly, the center of LFO excursion will be moved up, and again cause signal discontinuities. However, if enough Tap Dly is specified, Depth and Rate will be modulated smoothly.

As the LFOs sweep across the delay lines, the signal will change pitch. The pitch will change with a triangular envelope (rise-fall-rise-fall) or with a trapezoidal envelope (rise-hold-fall-hold). You can choose the pitch envelope with the Pitch Env parameter. Unfortunately rate and depth cannot be smoothly modulated when set to the “trapezoid” setting.

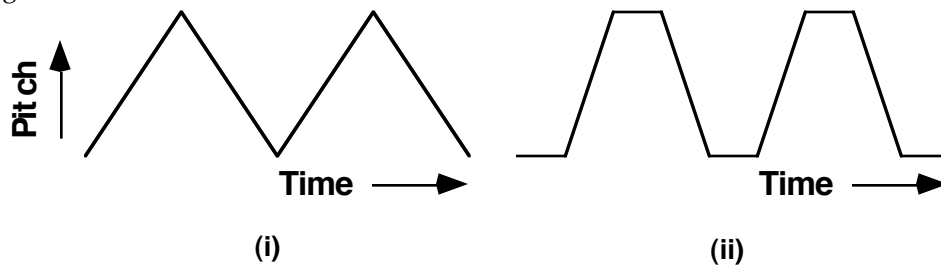

Pitch Envelope—(i) “Triangle”; (ii) “trapezoid”

Parameters (Chorus1):

PAGE 1

Wet/Dry	-100 to 100%wet	Out Gain	Off, -79.0 to 24.0 dB
Fdbk Level	-100 to 100%		
Xcouple	0 to 100%		
HF Damping	16 Hz to 25088 Hz	Pitch Env	Triangle or trapezoid

PAGE 2

Tap Lvl	-100 to 100%	LFO Rate	0.01 to 10.00 Hz
Tap Dly	0.0 to 1000.0 ms	LFO Depth	0.0 to 50.0 ct
		L/R Phase	0.0 to 360.0 deg

Parameters (Chorus 2):

PAGE 1

Wet/Dry	-100 to 100%wet	Out Gain	Off, -79.0 to 24.0 dB
Fdbk Level	-100 to 100%		
Xcouple	0 to 100%		
HF Damping	16 Hz to 25088 Hz	Pitch Env	Triangle or trapezoid

PAGE 2

Tap1 Lvl	-100 to 100%	Tap1 Dly	4.0 to 1000.0 ms
Tap2 Lvl	-100 to 100%	Tap2 Dly	4.0 to 1000.0 ms
Tap3 Lvl	-100 to 100%	Tap3 Dly	4.0 to 1000.0 ms

PAGE 3

LFO1 Rate	0.01 to 10.00 Hz	LFO1 LRPhs	0.0 to 360.0 deg
LFO2 Rate	0.01 to 10.00 Hz	LFO2 LRPhs	0.0 to 360.0 deg
LFO3 Rate	0.01 to 10.00 Hz	LFO3 LRPhs	0.0 to 360.0 deg
LFO1 Dpth	0.0 to 50.0 ct		
LFO2 Dpth	0.0 to 50.0 ct		
LFO3 Dpth	0.0 to 50.0 ct		

Parameters (Dual Chorus1):

PAGE 1

L Wet/Dry	-100 to 100%wet	R Wet/Dry	-100 to 100%wet
L Out Gain	Off, -79.0 to 24.0 dB	R Out Gain	Off, -79.0 to 24.0 dB
L Fdbk Lvl	-100 to 100%	R Fdbk Lvl	-100 to 100%
Xcouple	0 to 100%		

PAGE 2

L Tap Lvl	-100 to 100%	R Tap Lvl	-100 to 100%
L Tap Pan	-100 to 100%	R Tap Pan	-100 to 100%
L LFO Rate	0.01 to 10.00 Hz	R LFO Rate	0.01 to 10.00 Hz
L LFODepth	0.0 to 50.0 ct	R LFO Depth	0.0 to 50.0 ct
L Tap Dly	0.0 to 1000.0 ms	R Tap Dly	0.0 to 1000.0 ms
L HF Damp	16 Hz to 25088 Hz	R HF Damp	16 Hz to 25088 Hz

PAGE 3

L PitchEnv	Triangle or trapezoid	R PitchEnv	Triangle or trapezoid
------------	-----------------------	------------	-----------------------

Parameters (Dual Chorus 2):

PAGE 1

L Wet/Dry	-100 to 100%wet	R Wet/Dry	-100 to 100%wet
L Out Gain	Off, -79.0 to 24.0 dB	R Out Gain	Off, -79.0 to 24.0 dB
L Fdbk Lvl	-100 to 100%	R Fdbk Lvl	-100 to 100%
Xcouple	0 to 100%		

PAGE 2

L Tap1 Lvl	-100 to 100%	R Tap1 Lvl	-100 to 100%
L Tap2 Lvl	-100 to 100%	R Tap2 Lvl	-100 to 100%
L Tap3 Lvl	-100 to 100%	R Tap3 Lvl	-100 to 100%
L Tap1 Pan	-100 to 100%	R Tap1 Pan	-100 to 100%
L Tap2 Pan	-100 to 100%	R Tap2 Pan	-100 to 100%
L Tap3 Pan	-100 to 100%	R Tap3 Pan	-100 to 100%

PAGE 3

L LFO1Rate	0.01 to 10.00 Hz	R LFO1Rate	0.01 to 10.00 Hz
L LFO2Rate	0.01 to 10.00 Hz	R LFO2Rate	0.01 to 10.00 Hz
L LFO3Rate	0.01 to 10.00 Hz	R LFO3Rate	0.01 to 10.00 Hz
L LFO1Dpth	0.0 to 50.0 ct	R LFO1Dpth	0.0 to 50.0 ct
L LFO2Dpth	0.0 to 50.0 ct	R LFO2Dpth	0.0 to 50.0 ct
L LFO3Dpth	0.0 to 50.0 ct	R LFO3Dpth	0.0 to 50.0 ct

PAGE 4

L Tap1 Dly	0.0 to 1000.0 ms	R Tap1 Dly	0.0 to 1000.0 ms
L Tap2 Dly	0.0 to 1000.0 ms	R Tap2 Dly	0.0 to 1000.0 ms
L Tap3 Dly	0.0 to 1000.0 ms	R Tap3 Dly	0.0 to 1000.0 ms
L HF Damp	16 Hz to 25088 Hz	R HF Damp	16 Hz to 25088 Hz
L PitchEnv	Triangle or trapezoid	R PitchEnv	Triangle or trapezoid

- Wet/Dry The relative amount of input (dry) signal and chorus (wet) signal that appears in the final effect output mix. When set to 0%, the output is taken only from the input. When set to 100%, the output is all wet. Negative values polarity-invert the wet signal.
- Out Gain The overall gain or amplitude at the output of the effect.
- Fdbk Level The level of the feedback signal into the delay line. The feedback signal is taken from the LFO1 delay tap. Negative values polarity-invert the feedback signal.
- Xcouple Controls how much of the left channel input and feedback signals are sent to the right channel delay line and vice versa. At 50%, equal amounts from both channels are sent to both delay lines. At 100%, the left feeds the right delay and vice versa.
- HF Damping The amount of high-frequency content of the signal that is sent into the delay lines. This control determines the cutoff frequency of the one-pole (-6dB/octave) lowpass filter.
- Pitch Env The pitch of the chorus modulation can be made to follow a triangular “Triangle” envelope (rise-fall-rise-fall) or a trapezoidal “trapezoid” envelope (rise-hold-fall-hold).

<u>Tap Lvl</u>	Levels of the LFO-modulated delay taps. Negative values polarity-invert the signal. Setting any tap level to 0% effectively turns off the delay tap. Since these controls allow the full input level to pass through all the delay taps, a 100% setting on all the summed taps will significantly boost the wet signal relative to dry. A 50% setting may be more reasonable.
<u>Tap Pan</u>	The left or right output panning of the delay taps. The range is -100% for fully left to 100% for fully right. Setting the pan to 0% sends equal amounts to both left and right channels for center or mono panning. [Dual Chorus 1 & 2 only]
<u>LFO Rate</u>	Used to set the speeds of modulation of the delay lines. Low rates increase LFO excursion (see LFO Dpth below). If Pitch Env is set to “trapezoid”, you will be unable to put the rate on an FXMod or otherwise change the rate without introducing discontinuities (glitches or zippering) to your output signal. The triangular “Triangle” Pitch Env setting does allow smooth rate modulation, provided you’ve specified enough delay.
<u>LFO Depth</u>	The maximum depth of detuning of the LFO-modulated delay lines. The range is 0 to 50 cents, with a cent equal to 1/100th of a semitone. If you do not have enough delay specified with Tap Dly to get the depth you’ve dialed up, then Tap Dly will be forced to increase, which can cause discontinuities if signal is present. The LFOs move a tap back and forth across the delay lines to shift the pitch of the tapped signal. The maximum distance the taps get moved from the center position of the LFO is called the LFO excursion. Excursion is calculated from both the LFO depth and rate settings. Large depths and low rates produce large excursions. If Pitch Env is set to “trapezoid”, you will be unable to put the depth on an FXMod or otherwise change the depth without introducing discontinuities (glitches or zippering) to your output signal. The triangular “Triangle” Pitch Env setting does allow smooth depth modulation, provided you’ve specified enough delay.
<u>Tap Dly</u>	The average delay length, or the delay to the center of the LFO sweep. If the delay is shorter than the LFO excursion, then the Tap Dly will be forced to a longer length, equal to the amount of required excursion (the parameter display will not change though). Changing this parameter while signal is present will cause signal discontinuities. It’s best to set and forget this one. Set it long enough so that there are no discontinuities with the largest Depth and lowest Rates that you will be using.
<u>L/R Phase or LFO_n LRPhs</u>	In Chorus 1 and Chorus 2, the relative phases of the LFOs for the left and right channels may be adjusted.

FXAlg #154: Flanger 1 • FXAlg #155: Flanger 2

Multi-tap flangers

Allocation Units: 1 for Flanger 1; 2 for Flanger 2

Flanger 1 is a 1-PAU multi-sweep Thru-zero flanger effect with two LFOs per channel.

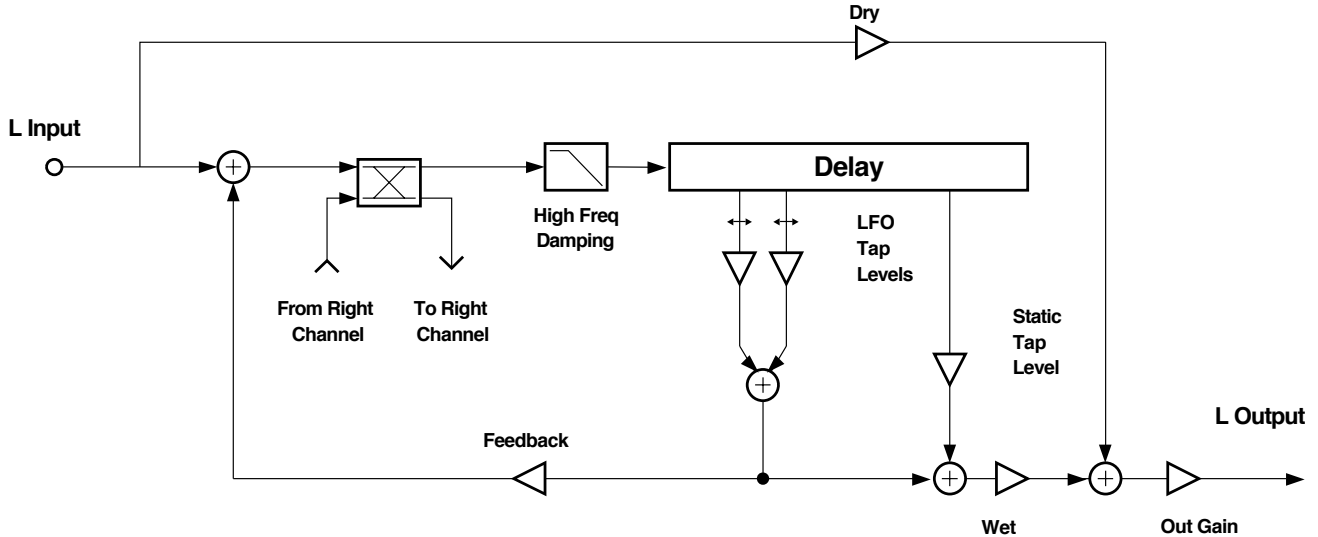

Simplified block diagram of the left channel of Flanger 1; the Right channel is similar.

Flanger 2 is a 2-PAU multi-sweep Thru-zero flanger effect with two LFOs per channel.

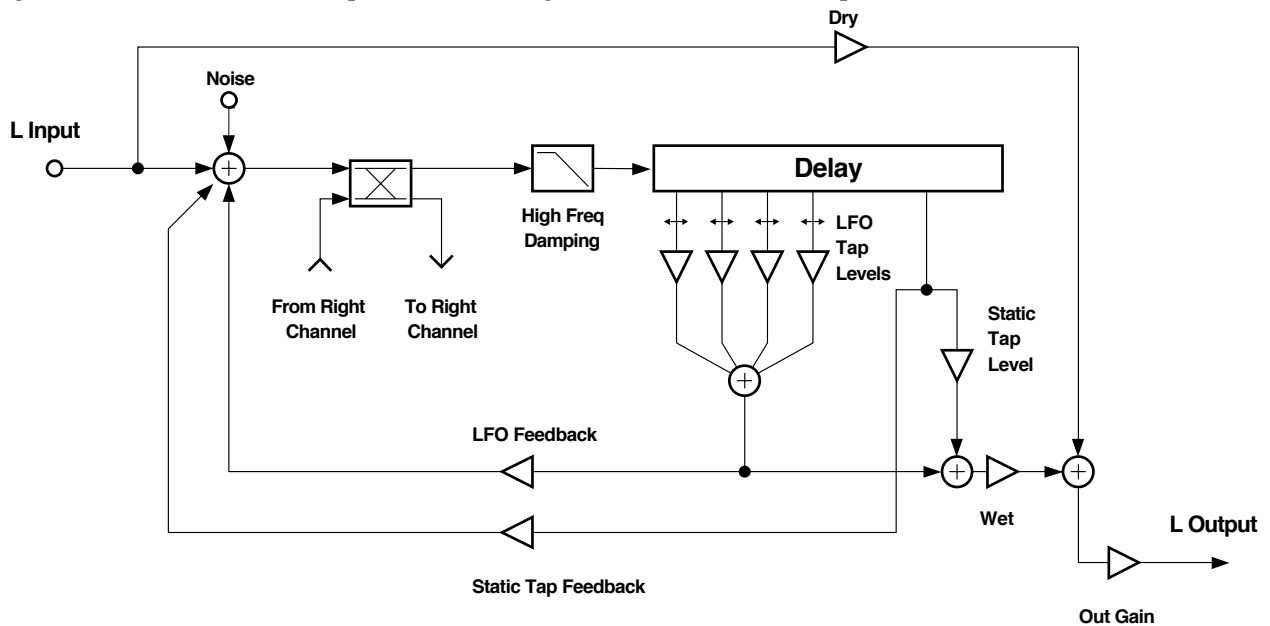

Simplified block diagram of the left channel of Flanger 2; the Right channel is similar.

Flanging was originally created by summing the outputs of two un-locked tape machines while varying their sync by pressing a hand on the outside edge of one reel—thus the name “reel-flanging”. The key to achieving the flanging effect is the summing of a signal with a time-displaced replica of itself.

The result is a series of notches in the frequency spectrum. These notches are equally spaced in (linear) frequency at multiples whose wavelengths are equal to the time delay. The result is generally referred to as a comb filter (the name arising from the resemblance of the spectrum to a comb). If the levels of the signals being added or subtracted are the same, the notches will be of infinite depth (in dB) and the peaks will be up 6 dB. Flanging is achieved by time-varying the delay length, thus changing the frequencies of the notches. The shorter the delay time, the greater the notch separation. This delay time variation imparts a sense of motion to the sound. Typically the delay times are on the order of 0-5 ms. Longer times begin to get into the realm of chorusing, where the ear begins to perceive the audio output as nearly two distinct signals, but with a variable time displacement.

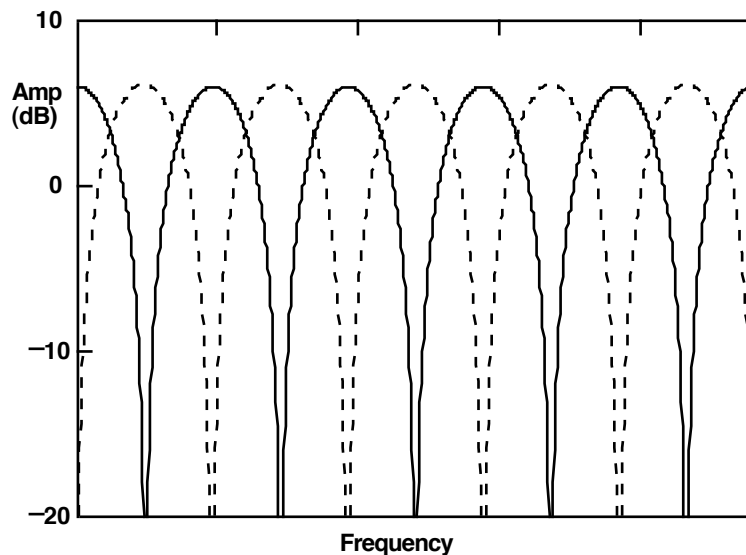

Comb Filters - Solid Line for Addition, Dashed Line for Subtraction

The heart of the flanger implemented here is a multi-tap delay line. You can set the level of each tap as a percentage of the input level, and the level may be negative (phase-inverted). One tap is a simple static delay over which you can control the length of delay (from the input tap). Four of the taps can have their lengths modulated up and down by a low frequency oscillator (LFO). You are given control of the rate of the LFOs, how far each LFO can sweep through the delay line, and the relative phases of the LFOs (i.e., whether the LFO is taking the taps from the input tap or bringing them toward it).

The flanger uses tempo units (based on the sequencer tempo or MIDI clock if you like), together with the number of tempo beats per LFO cycle. Thus if the tempo is 120 bpm (beats per minute) and the LFO Period is set to 1 beat, the LFOs will pass through 120 complete cycles in a minute or 2 cycles per second (2 Hz). Increasing the LFO Period increases the period of the LFOs (slows them down). An LFO Period setting of 16 beats will take 4 measures (in 4/4 time) for a complete LFO oscillation.

You can set how far each LFO can sweep through the delay line with the excursion controls (Xcurs). The excursion is the maximum distance an LFO will move from the center of its sweep. The total range of an LFO is twice the excursion. You set the delay to the center of LFO excursion with the Dly parameters. The excursion and delay controls both have coarse and fine adjustments. By setting the excursion to zero length, the LFO delay tap becomes a simple static tap. Note that modifying the delay to the center of LFO excursion will result in a sudden change of delay length and consequently, a discontinuity in the signal being read from the delay line. This can produce a characteristic zippering effect. The Dly parameters should be as long as the Xcurs parameters or longer, or else changing (or modulating) the excursion will force the center of LFO excursion to move, with the resulting signal discontinuities. The static delay tap does not suffer the zippering problem, and changes to its length will occur smoothly. You can assign the static delay tap to an FX Mod, and use the source controller to do manual flanging.

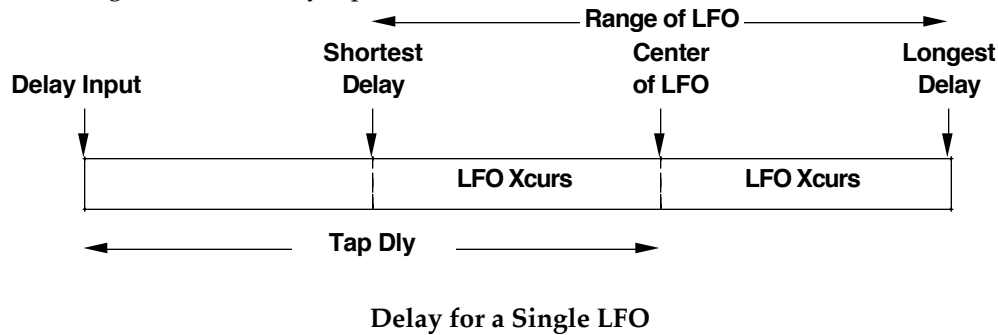

Consider a simple example where you have an LFO tap signal being subtracted from the static delay tap signal. If the delays are set such that at certain times both taps are the same length, then both taps have the same signal and the subtraction produces a null or zero output. The effect is most pronounced when the static tap is set at one of the ends of the LFO excursion where the LFO tap motion is the slowest. This is the classic Thru-Zero flanger effect. Adding other LFO taps to the mix increases the complexity of the final sound, and obtaining a true Thru-Zero effect may take some careful setting of delays and LFO phases.

The flanger has a Wet/Dry control as well, which can further add complexity to the output as the dry signal is added to various delayed wet components for more comb filtering.

When using more than one LFO, you can set up the phase relationships between each of the LFOs. The LFOs of the left channel and those of the right channel will be set up in the same phase relationship except that you may offset the phases of the right channel as a group relative to the left channel (L/R Phase). L/R Phase is the only control which treats left and right channels differently and has a significant effect on the stereo image. If you have tempo set to the system tempo, the phases will maintain their synchronization with the tempo clock. At the beat of the tempo clock, a phase set to 0° will be at the center of the LFO excursion and moving away from the delay input.

Regenerative feedback has been incorporated in order to produce a more intense resonant effect. The signal is fed back is from the first LFO delay tap (LFO1), and has its own level control (Fdbk Level). In-phase spectral components arriving at the summer add together, introducing a series of resonant peaks in the frequency spectrum between the notches. The amplitude of these peaks depends on the degree of feedback, and they can be made very resonant.

Cross-coupling (Xcouple) allows the signals of the right and left channels to be mixed or swapped. The cross-coupling is placed after the summation of the feedback to the input signal. When feedback and cross-coupling are turned up, you will get a ping-pong effect between right and left channels.

A lowpass filter (HF Damping) right before the input to the delay line is effective in emulating the classic sounds of older analog flangers with their limited bandwidths (typically 5-6kHz).

As stated earlier, it is the movement of the notches created in the frequency spectrum that give the flanger its unique

sound. It should be obvious that sounds with a richer harmonic structure will be effected in a much more dramatic way than harmonically starved sounds. Having more notches, i.e. a greater ‘notch-density’, should produce an even more intense effect. This increase in notch density may be achieved by having a number of modulating delay lines, all set at the same rate, but different depths. Setting the depths proportionately results in a more pleasing effect.

An often characteristic effect of flanging is the sound of system noise being flanged. Various pieces of analog gear add noise to the signal, and when this noise passes through a flanger, you can hear the noise “whooshing”. In the K2500, the noise level is very low, and in fact if no sound is being played, there is no noise at all at this point in the signal chain. To recreate the effect of system noise flanging, white noise may be added to the input of the flanger signal (Flanger 2 only). Since white noise has a lot of high frequency content and may sound too bright, it may be tamed with a first-order lowpass filter.

Parameters (Flanger 1):

PAGE 1

Wet/Dry	-100 to 100% wet	Out Gain	Off, -79.0 to 24.0 dB
Fdbk Level	-100 to 100%	LFO Tempo	System, 1 to 255 BPM
Xcouple	0 to 100%	LFO Period	1/24 to 32 bts
HF Damping	16 to 25088 Hz		

PAGE 2

StatDlyLvl	-100 to 100%	L/R Phase	0.0 to 360.0 deg
LFO1 Level	-100 to 100%	LFO1 Phase	0.0 to 360.0 deg
LFO2 Level	-100 to 100%	LFO2 Phase	0.0 to 360.0 deg

PAGE 3

StatDlyCrs	0.0 to 228.0 ms		
StatDlyFin	-127 to 127 samp		
Xcurs1 Crs	0.0 to 228.0 ms	Dly1 Crs	0.0 to 228.0 ms
Xcurs1 Fin	-127 to 127 samp	Dly1 Fin	-127 to 127 samp
Xcurs2 Crs	0.0 to 228.0 ms	Dly2 Crs	0.0 to 228.0 ms
Xcurs2 Fin	-127 to 127 samp	Dly2 Fin	-127 to 127 samp

Parameters (Flanger 2):

PAGE 1

Wet/Dry	-100 to 100%wet	Out Gain	Off, -79.0 to 24.0 dB
LFO Fdbk	-100 to 100%	Stat Fdbk	-100 to 100%
Xcouple	0 to 100%	LFO Tempo	System, 1 to 255 BPM
HF Damping	16 Hz to 25088 Hz	LFO Period	1/24 to 32 bts

PAGE 2

Noise Gain	Off, -79.0 to -30.0 dB	Noise LP	16 to 25088 Hz
StatDlyLvl	-100 to 100%	L/R Phase	0.0 to 360.0 deg
LFO1 Level	-100 to 100%	LFO1 Phase	0.0 to 360.0 deg
LFO2 Level	-100 to 100%	LFO2 Phase	0.0 to 360.0 deg
LFO3 Level	-100 to 100%	LFO3 Phase	0.0 to 360.0 deg
LFO4 Level	-100 to 100%	LFO4 Phase	0.0 to 360.0 deg

PAGE 3

StatDlyCrs	0.0 to 228.0 ms		
StatDlyFin	-127 to 127 samp		
Xcurs1 Crs	0.0 to 228.0 ms	Xcurs3 Crs	0.0 to 228.0 ms
Xcurs1 Fin	-127 to 127 samp	Xcurs3 Fin	-127 to 127 samp
Xcurs2 Crs	0.0 to 228.0 ms	Xcurs4 Crs	0.0 to 228.0 ms
Xcurs2 Fin	-127 to 127 samp	Xcurs4 Fin	-127 to 127 samp

PAGE 4

Dly1 Crs	0.0 to 228.0 ms	Dly3 Crs	0.0 to 228.0 ms
Dly1 Fin	-127 to 127 samp	Dly3 Fin	-127 to 127 samp
Dly2 Crs	0.0 to 228.0 ms	Dly4 Crs	0.0 to 228.0 ms
Dly2 Fin	-127 to 127 samp	Dly4 Fin	-127 to 127 samp

- Wet/Dry The relative amount of input signal and flanger signal that is to appear in the final effect output mix. When set to 0%, the output is taken only from the input (dry). When set to 100%, the output is all wet. Negative values polarity-invert the wet signal.
- Out Gain The overall gain or amplitude at the output of the effect.
- Fdbk Level The level of the feedback signal into the delay line. The feedback signal is taken from the LFO1 delay tap. Negative values polarity-invert the feedback signal.
- Xcouple How much of the left channel input and feedback signals are sent to the right channel delay line and vice versa. At 50%, equal amounts from both channels are sent to both delay lines. At 100%, the left feeds the right delay and vice versa. Xcouple has no effect if Fdbk Level is set to 0%.
- HF Damping The amount of high frequency content of the signal sent into the delay lines. This control determines the cutoff frequency of the one-pole (-6dB/octave) lowpass filters.
- LFO Tempo Basis for the rates of the LFOs, as referenced to a musical tempo in bpm (beats per minute). When this parameter is set to "System", the tempo is locked to the internal sequencer tempo or to incoming MIDI clocks. When it is set to "System", sources (FUNs, LFOs, ASRs etc.) will have no effect on the Tempo parameter.
- LFO Period Sets the LFO rate based on the Tempo determined above: the number of beats corresponding to one period of the LFO cycle. For example, if the LFO Period is set to "4", the LFOs will take four beats to pass through one oscillation, so the LFO rate will be 1/4th of the Tempo setting. If it is set to "6/24" (=1/4), the LFO will oscillate four times as fast as the Tempo. At "0", the LFOs stop oscillating and their phase is undetermined (wherever they stopped).

<u>Noise Gain</u>	The amount of noise (dB relative to full scale) to add to the input signal. In many flangers, you can hear the noise floor of the signal being flanged, but in the K2500, if there is no input signal, there is no noise floor unless it is explicitly added. [Flanger 2 only]
<u>Noise LP</u>	The cut-off frequency of a one-pole lowpass filter acting on the injected noise. The lowpass removes high frequencies from an otherwise pure white noise signal. [Flanger 2 only]
<u>StatDlyCrs</u>	The coarse adjustment to the static delay tap length. The name suggests the tap is stationary, but it can be connected through an FX Mod to a control source to smoothly vary the delay length. The range for all delays and excursions is 0 to 230 ms, but for flanging the range 0 to 5 ms is most effective.
<u>StatDlyFin</u>	A fine adjustment to the static delay tap length. The resolution is one sample.
<u>StatDlyLvl</u>	The level of the static delay tap. Negative values polarity-invert the signal. Setting the tap level to 0% turns off the delay tap.
<u>Xcurs n Crs</u>	These set how far the LFO-modulated delay taps can move from the center of their ranges. The total range of the LFO sweep is twice the excursion. If the excursion is set to 0, the LFO does not move and the tap behaves like a simple delay line set to the minimum delay. The excursion cannot be made longer than the delay to the center of excursion (see <u>Dly Crs</u> and <u>Dly Fin</u> below) because delays cannot be made shorter than 0. If you attempt longer excursions, the length of the Dly Crs/Fin will be forced to increase (though you will not see the increased length displayed in the Dly Crs/Fin parameters), and you will hear discontinuities in the signal, usually in the form of zipper noise. The range for all delays and excursions is 0 to 230 ms, but for flanging the range 0 to 5 ms is most effective. This parameter is a coarse adjustment for the excursion.
<u>Xcurs n Fin</u>	A fine adjustment for the LFO excursions. The resolution is one sample.
<u>Dly n Crs</u>	The delay to the center of LFO tap range. The maximum delay will be this delay plus the LFO excursion delay. The minimum delay will be this delay minus the LFO excursion delay. Since delays cannot be less than 0 ms in length, the this delay length will be increased if LFO excursion is larger than this delay length. The range for all delays and excursions is 0 to 230 ms, but for flanging the range 0 to 5 ms is most effective. This parameter is a coarse adjustment for the delay.
<u>Dly n Fin</u>	A fine adjustment to the minimum delay tap lengths. The resolution is one sample.
<u>LFO_n Level</u>	The levels of the LFO modulated delay taps. Negative values polarity-invert the signal. Setting any tap level to 0% turns off the delay tap.
<u>LFO_n Phase</u>	The phase angles of the LFOs relative to each other and to the system tempo clock, if turned on (see <u>Tempo</u>). For example, if one LFO is set to 0° and another is set to 180°, then when one LFO delay tap is at its shortest, the other will be at its longest. If the system tempo clock is on, the LFOs are synchronized to the clock with absolute phase. A phase of 0° will put an LFO tap at the center of its range and its lengthening.
<u>L/R Phase</u>	Adds the specified phase angle to the right channel LFOs. In all other respects the right and left channels are symmetric. By moving this control away from 0°, the stereo sound field is broken up and a stereo image becomes difficult to spatially locate. The effect is usually described as “phasey”. It tends to impart a greater sense of motion.

FX Algs #156-160: Phasers

- FXAlg #156: LFO Phaser**
- FXAlg #157: LFO Phaser Twin**
- FXAlg #158: Manual Phaser**
- FXAlg #159: Vibrato Phaser**
- FXAlg #160: SingleLFO Phaser**

A variety of single notch/bandpass Phasers

Allocation Units: 1 (each)

A simple phaser is an algorithm which produces a vague swishing or phasey effect. When the phaser signal is combined with the dry input signal or the phaser is fed back on itself, peaks and/or notches can be produced in the filter response making the effect much more pronounced. Most of the phaser algorithms presented here have built in low frequency oscillators (LFOs) to generate the motion of the phasers. In the case of Manual Phaser, the phaser motion is left to the user.

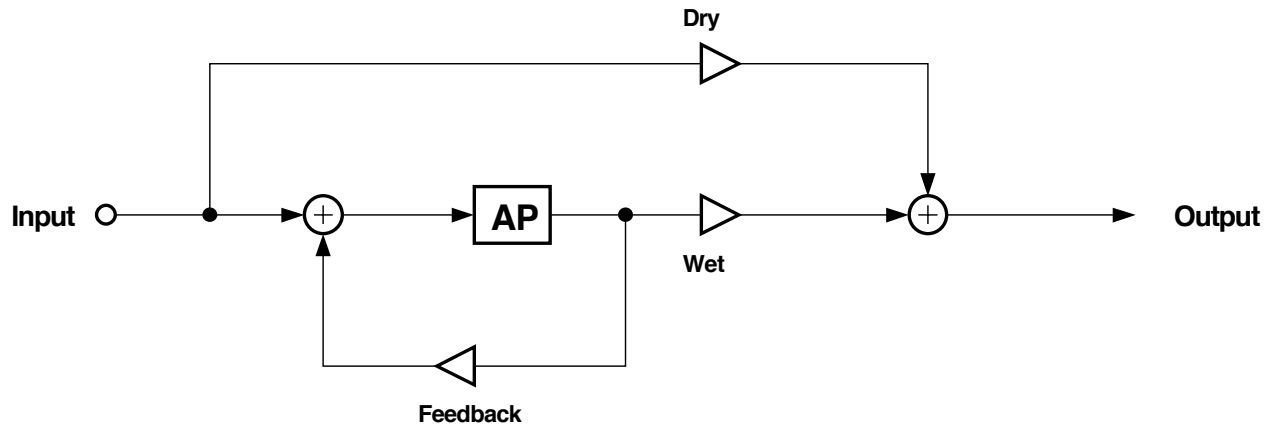

One channel of a typical phaser

A phaser uses a special filter called an all-pass filter to modify the phase response of a signal's spectrum without changing the amplitude of the spectrum. As the name suggests, an all-pass filter by itself does not change the amplitude of the frequency response of a signal passing through it—it does not cut or boost any frequencies. It does cause some frequencies to be delayed a little in time, and this small time shift is also known as a phase change. The frequency where the phase change has its greatest effect is a parameter that you can control. By modulating the frequency of the phaser, you get the swishy phaser sound. With a modulation rate of around 6 Hz, an effect similar to vibrato may be obtained, but only in a limited range of filter frequencies.

By adding the phaser output to the dry input using, for example, a Wet/Dry parameter, you can produce peaks and notches in the frequency response. At frequencies where the phaser is "in phase" with the dry signal, the signal level doubles (or there is a 6 dB level increase approximately). At frequencies where the phaser and dry signals are "out of phase", the two signals cancel each other out and there is a notch in the frequency response. You can get a complete notch when Wet/Dry is set to 50%. If subtraction is used instead of addition by setting Wet/Dry to -50%, then the notches become peaks and the peaks become notches.

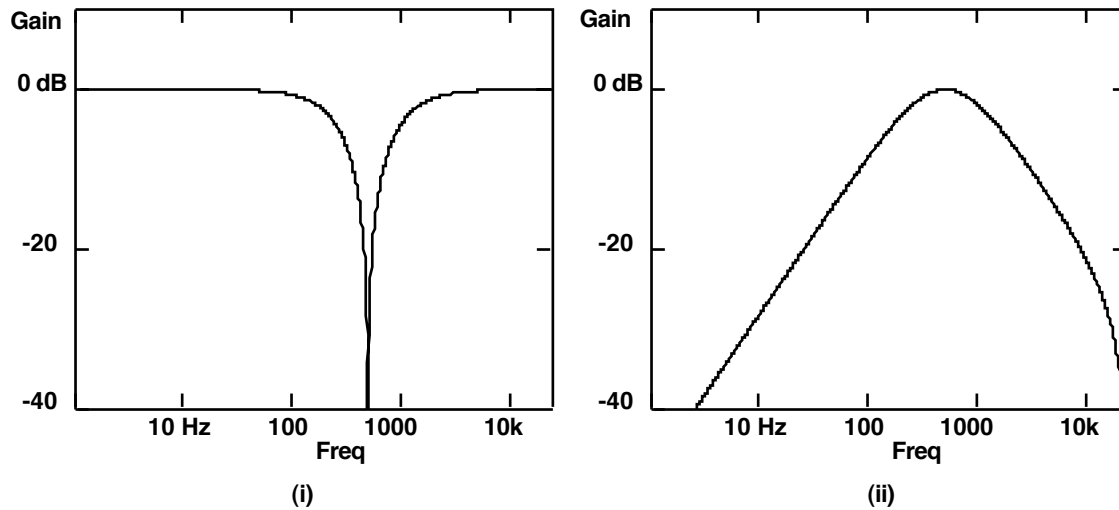

Response of typical phaser: (i) Wet/Dry = 50% and (ii) Wet/Dry = -50%.

Some of the phaser algorithms have feedback. When feedback is used, it can greatly exaggerate the peaks and notches, producing a much more resonant sound.

LFO Phaser is a simple phaser algorithm with Wet/Dry and Fdbk Level parameters. Two LFOs used to control the filter frequency and the depth of the resulting notch. You can control the depths, rates, and phases of both the LFOs. The algorithm is stereo so the relative phases of the LFOs for the left and right channels can be set. When setting the LFO that controls the filter frequency, you specify the center frequency around which the LFO will modulate and the depth of the LFO. The depth specifies how many cents (hundredths of a semitone) to move the filter frequency up and down.

The NotchDepth parameter provides an alternative way of combining wet and dry phaser signals to produce a notch. In this case the parameter specifies the depth of the notch in decibels (dB). The depth of the notch can be modulated with the notch LFO. The notch LFO is completely independent of the frequency, and their rates may be different. The relative phases of the notch and frequency LFOs (N/F Phase) only has meaning when the LFOs are running at the same rate. As with all KDFX LFO phases, it is not recommended to directly modulate the phase settings with an FXMod.

SingleLFO Phaser is identical to LFO Phaser except that the notch and frequency LFOs always run at the same rate.

Manual Phaser leaves the phaser motion up to you, so it has no built in LFOs. Manual Phaser has a Notch/BP parameter which produces a complete notch at the center frequency when Wet/Dry is set to -100% and a resonant bandpass when set to 100%. At 0% the signal is dry. To get phaser motion, you have to change the filter center frequencies (left and right channels) yourself. The best way to do this is with an FXMod. There are also feedback parameters for the left and right channels.

LFO Phaser Twin produces a pair of notches separated by a spectral peak. The center frequency parameter sets the frequency of the center peak. Like LFO Phaser, the filter frequency can be modulated with a built in LFO. The Notch/Dry parameter produces a pair of notches when set to 100%. The output signal is dry when set to 0% and at 200%, the signal is a pure (wet) allpass response. LFO Phaser Twin does not have Out Gain or feedback parameters.

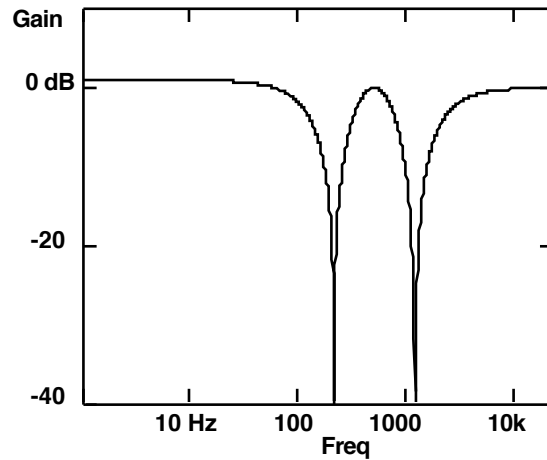

Response of LFO Phaser Twin with Wet/Dry set to 100%.

In the Vibrato Phaser algorithm, the bandwidth of the phaser filter can be adjusted exactly like a parametric EQ filter. The In Width controls how the stereo input signal is routed through the effect. At 100% In Width, left input is processed to the left output, and right to right. Lower In Width values narrow the input stereo field until at 0%, the processing is mono. Negative values reverse left and right channels. The dry signal is not affected by In Width. As described earlier, setting Wet/Dry to 50% will produce a full notch. At -50% Wet/Dry, you get a bandpass.

Parameters (LFO Phaser):

PAGE 1

Wet/Dry	0 to 100%wet	Out Gain	Off, -79.0 to 24.0 dB
Fdbk Level	-100 to 100%		

PAGE 2

CenterFreq	16 to 25088 Hz	NotchDepth	-79.0 to 6.0 dB
FLFO Depth	0 to 5400 ct	NLFO Depth	0 to 100%
FLFO Rate	0.00 to 10.00 Hz	NLFO Rate	0.00 to 10.00 Hz
FLFO LRPhs	0.0 to 360.0 deg	NLFO LRPhs	0.0 to 360.0 deg
		N/F Phase	0.0 to 360.0 deg

Parameters (SingleLFO Phaser):

PAGE 1

Wet/Dry	0 to 100%wet	Out Gain	Off, -79.0 to 24.0 dB
Fdbk Level	-100 to 100%		

PAGE 2

LFO Rate	0.00 to 10.00 Hz	N/F Phase	
CenterFreq	16 to 25088 Hz	NotchDepth	-79.0 to 6.0 dB
FLFO Depth	0 to 5400 ct	NLFO Depth	0 to 100%
FLFO LRPhs	0.0 to 360.0 deg	NLFO LRPhs	0.0 to 360.0 deg

<u>Wet/Dry</u>	The amount of phaser (wet) signal relative to unaffected (dry) signal as a percent.
<u>Out Gain</u>	The output gain in decibels (dB) to be applied to the combined wet and dry signals.
<u>Fdbk Level</u>	The phaser output can be added back to its input to increase the phaser resonance. Negative values polarity-invert the feedback signal.
<u>LFO Rate</u>	The rate of both the center frequency LFO and the notch depth LFO for the SingleLFO Phaser algorithm.
<u>CenterFreq</u>	The nominal center frequency of the phaser filter. The frequency LFO modulates the phaser filter centered at this frequency.
<u>FLFO Depth</u>	The depth in cents that the frequency LFO sweeps the phaser filter above and below the center frequency.
<u>FLFO Rate</u>	The rate of the center frequency LFO for the LFO Phaser algorithm.
<u>FLFO LRPhs</u>	Sets the phase difference between the left and right channels of the center frequency LFO. A setting of 180 degrees results in one channel being at the minimum frequency while the other channel is at the maximum.
<u>NotchDepth</u>	The nominal depth of the notch. The notch depth LFO modulates the depth of the notch. For maximum LFO depth, set NotchDepth to 0 dB and NLFO Depth to 100%.
<u>NLFO Depth</u>	The excursion of the notch depth LFO in units of percentage of the total range. The depth of the LFO is limited to the range of the NotchDepth parameter such that a full 100% modulation is only possible when the NotchDepth is at the center of its range (0 dB).
<u>NLFO Rate</u>	The rate of the notch depth LFO for the LFO Phaser algorithm.
<u>NLFO LRPhs</u>	The phase difference between the left and right channels of the notch depth LFO. A setting of 180 degrees results in one channel being at highest amplitude while the other channel is at lowest amplitude.
<u>N/F Phase</u>	The phase difference between the notch depth and center frequency LFOs. For LFO Phaser, this parameter is largely meaningless unless the FMod Rate and NMod Rate are set identically.

Parameters (Manual Phaser):

PAGE 1

Notch/BP	-100 to 100%	Out Gain	Off, -79.0 to 24.0 dB
L Feedback	-100 to 100%	R Feedback	-100 to 100%
L Ctr Freq	16 to 25088 Hz	R Ctr Freq	16 to 25088 Hz

- Notch/BP The amount of notch depth or bandpass. At -100% there is a complete notch at the center frequency. At 100% the filter response is a peak at the center frequency. 0% is the dry unaffected signal.
- Out Gain The output gain in decibels (dB) to be applied to the final output.
- Feedback The phaser output can be added back to its input to increase the phaser resonance (left and right). Negative values polarity-invert the feedback signal.
- Ctr Freq The nominal center frequency of the phaser filter (left and right). For a true phaser effect you may want to modulate these parameters by setting up FX Mods.

Parameters (LFO Phaser Twin):

PAGE 1

Notch/Dry	0 to 200%		
CenterFreq	16 to 25088 Hz	LFO Rate	0.00 to 10.00 Hz
LFO Depth	0 to 5400 ct	L/R Phase	0.0 to 360.0 deg

- Notch/Dry The amount of phaser (wet) signal relative to unaffected (dry) signal as a percent. At 100% the phaser produces a pair of full notches above and below the center frequency. At 200% the output is a pure all-pass response (no amplitude changes, but phase changes centered about the center frequency).
- CenterFreq The nominal center frequency of the phaser filter. When configured for a maximum notch (Notch/Dry is 100%), the CenterFreq specifies the frequency of the peak between two notches. The LFO modulates the phaser filter centered at this frequency.
- LFO Rate The rate of the phaser frequency modulating LFO in Hertz.
- LFO Depth The depth in cents that the frequency LFO sweeps the phaser filter above and below the center frequency.
- L/R Phase The phase difference between the left and right channels of the LFO. A setting of 180 degrees results in one channel being at the minimum frequency while the other channel is at the maximum.

Parameters (Vibrato Phaser):

PAGE 1

Wet/Dry	-100 to 100%wet	Out Gain	Off, -79.0 to 24.0 dB
----------------	------------------------	-----------------	------------------------------

PAGE 2

CenterFreq	16 to 25088 Hz	Bandwidth	0.010 to 5.000 oct
LFO Depth	0 to 100%	L/R Phase	0.0 to 360.0 deg
LFO Rate	0.00 to 10.00 Hz		
		In Width	-100 to 100%

<u>Wet/Dry</u>	The amount of phaser (wet) signal relative to unaffected (dry) signal as a percent. When set to 50% you get a complete notch. When set to -50%, the response is a bandpass filter. 100% is a pure allpass filter (no amplitude changes, but a strong phase response).
<u>Out Gain</u>	The output gain in decibels (dB) to be applied to the combined wet and dry signals.
<u>CenterFreq</u>	The nominal center frequency of the phaser filter. The frequency LFO modulates the phaser filter centered at this frequency.
<u>Bandwidth</u>	If the phaser is set to behave as a sweeping notch or bandpass, the bandwidth of the notch or bandpass is set with Bandwidth. This parameter works the same as for parametric EQ filter bandwidths.
<u>LFO Depth</u>	The depth that the frequency LFO sweeps the phaser filter above and below the center frequency as a percent.
<u>LFO Rate</u>	The rate of the LFO in Hertz. The LFO Rate may be scaled up by the Rate Scale parameter.
<u>L/R Phase</u>	Sets the phase difference between the left and right channels of the center frequency LFO. A setting of 180 degrees results in one being at a at the minimum frequency while the other channel is at the maximum.
<u>In Width</u>	The width of the stereo field that passes through the stereo phaser filtering. This parameter does not affect the dry signal. When set to 100%, the left and right channels are processed to their respective outputs. Smaller values narrow the stereo image until at 0% the input channels are summed to mono and set to left and right outputs. Negative values interchange the left and right channels.

Combination Algorithms [“+”]

- FXAlg #700 — Chorus+Delay**
- FXAlg #701 — Chorus+4Tap**
- FXAlg #703 — Chor+Dly+Reverb**
- FXAlg #706 — Flange+Delay**
- FXAlg #707 — Flange+4Tap**
- FXAlg #709 — Flan+Dly+Reverb**
- FXAlg #722 — Pitcher+Chor+Dly**
- FXAlg #723 — Pitcher+Flan+Dly**

A family of combination effect algorithms
Allocation Units: 1 or 2

Signal Routing (2 effects)

The algorithms listed above with two effects can be arranged in series or parallel. The output of the first effect in the algorithm name—A—is wired to the input of the second effect—B—and the input into effect B is a mix of effect A and the algorithm input dry signal. The effect B input mix is controlled by a parameter *A/Dry>B*. For example, in Chorus+Delay, the parameter name is “Ch/Dry>Dly”. The value functions much like a wet/dry mix where 0% means that only the algorithm input dry signal is fed into effect B, thus putting the effects in parallel; and 100% means only the output of effect A is fed into effect B, thus putting the effects in series.

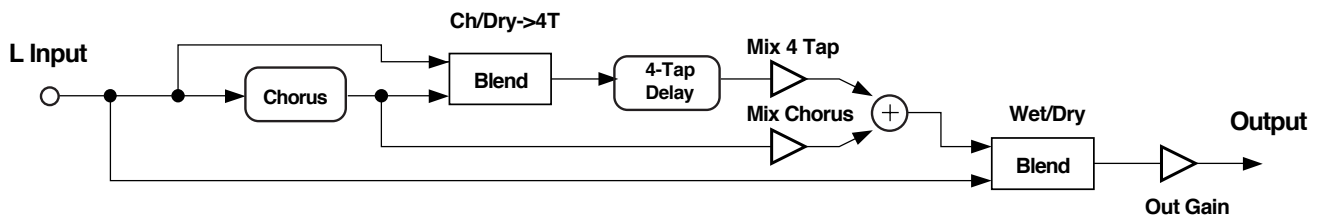

An example of routing using Chorus+4Tap

Both effect A and B outputs are mixed at the algorithm output to become the wet signal. These mix levels are controlled with the two parameters that begin with “Mix”. These allow only one or both effect outputs to be heard. Negative mix amounts polarity-invert the signal, which can change the character of each effect when mixed together or with the dry signal. The Wet/Dry parameter adjusts the balance between the sum of both effects determined by the Mix parameters, and the input dry signal. Negative Wet/Dry values polarity-invert the summed wet signal relative to dry.

Two-Effect Routing:

Wet/Dry	-100 to 100%	Out Gain	Off; -79.0 to 24.0 dB
Mix Effect	-100 to 100%		
Mix Effect	-100 to 100%		
		A/Dry->B	0 to 100%

Mix Effect

Adjusts the amount of each effect that is mixed together as the algorithm wet signal. Negative values polarity-invert that particular signal.

A/Dry->B

This parameter controls how much of the A effect is mixed with dry and fed into the B effect. A and B are designated in the algorithm name. This control functions like a wet/dry mix, where 0% is completely dry and 100% is effect A only.

Signal Routing (3 effects)

The algorithms listed above with three effects allow serial or parallel routing between any three effects. Effect A is wired to the input of effect B and C, and effect B is wired into effect C. The input of effect B is a mix between effect A and the algorithm dry input. The input into effect C is a three-way mix between effect A, effect B, and the dry signal.

As in the two-effect routing, the input of effect B is controlled by a parameter *A/Dry>B*. For example, in *Chor+Dly+Rvb*, the parameter name is “*Ch/Dly>Dly*”.

The input into effect C is controlled by two parameters named *A/B ->** and **/Dry->C* where A, B, and C correspond to the names of effects A, B, and C. The first parameter mixes effect A and B into a temporary buffer represented by the symbol “*”. The second parameter mixes this temporary buffer “*” with the dry signal to be fed into effect C. These mixing controls function similarly to *Wet/Dry* parameters. A setting of 0% only mixes the effect to the right of the “/” in the parameter name, while 100% only mixes the effect to the left of the “/”. Negative values polarity-invert the numerator’s signal.

Effects A, B, and C outputs are mixed at the algorithm output to become the wet signal. Separate mixing levels are provided for left and right channels, and are named “L Mix” or “R Mix”. Negative mix amounts polarity-invert the signal which can change the character of each effect when mixed together or with the dry signal. The *Wet/Dry* parameter adjusts the balance between the sum of all effects determined by the Mix parameters, and the input dry signal. Negative *Wet/Dry* values polarity-invert the summed wet signal relative to dry.

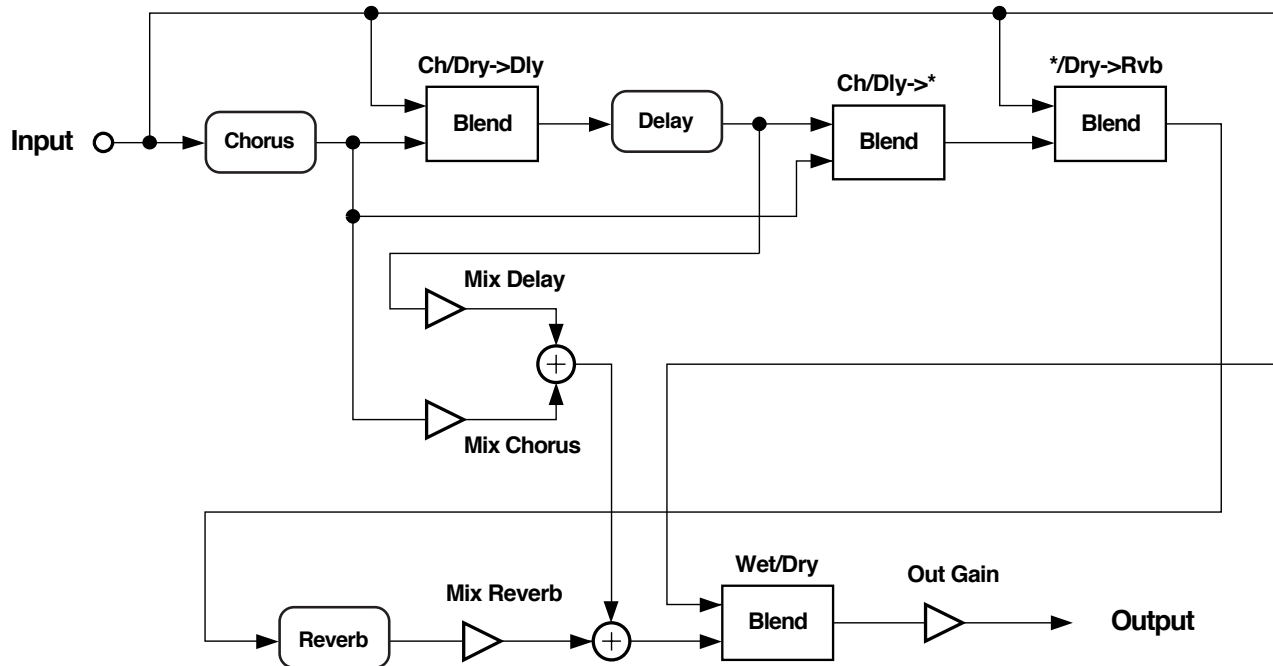

An example of routing using Chorus+Delay+Reverb

Combination Algorithms [“+”]

Three-Effect Routing:

Wet/Dry	-100 to 100%	Out Gain	Off; -79.0 to 24.0 dB
L Mix Effect A	-100 to 100%	R Mix Effect A	-100 to 100%
L Mix Effect B	-100 to 100%	R Mix Effect B	-100 to 100%
L Mix Effect C	-100 to 100%	R Mix Effect C	-100 to 100%

A/Dry>B	-100 to 100%
A/B ->*	-100 to 100%
*/Dry->C	-100 to 100%

L Mix Effect, R Mix Effect Adjusts the amount of each effect that is mixed together as the algorithm wet signal. Separate left and right controls are provided. Negative values polarity-invert that particular signal.

A/Dry>B This parameter controls how much of the A effect is mixed with dry and fed into the B effect. A and B are designated in the algorithm name. This control functions like a wet/dry mix, where 0% is completely dry and 100% is effect A only.

A/B ->* This parameter is first of two parameters that control what is fed into effect C. This adjusts how much of the effect A is mixed with effect B, the result of which is represented as the symbol “*”. 0% is completely B effect, and 100% is completely A effect. negative values polarity-invert the A effect.

/Dry->C This parameter is the second of two parameters that control what is fed into effect C. This adjusts how much of the “” signal (sum of effects A and B determined by A/B ->*) is mixed with the dry signal and fed into effect C. 0% is completely dry signal, and 100% is completely “*” signal.

Individual Effect Components

Chorus:

The choruses are basic 1 tap dual choruses. Separate LFO controls are provided for each channel. Slight variations between algorithms exist. Some algorithms offer separate left and right feedback controls, while some offer only one for both channels. Also, cross-coupling and high frequency damping may be offered in some and not in others. Parameters associated with chorus control begin with “Ch” in the parameter name. A general description of chorus functionality can be found in the Chorus section of this book, FXAlgs #150-153.

Ch PtchEnv	Triangle or trapezoid		
Ch Rate L	0.01 to 10.00 Hz	Ch Rate R	0.01 to 10.00 Hz
Ch Depth L	0.0 to 100 ct	Ch Depth R	0.0 to 100 ct
Ch Delay L	0 to 1000 ms	Ch Delay R	0 to 1000 ms
Ch Fdbk	-100 to 100%		
Ch Xcouple	0 to 100%	Ch HF Damp	16 to 25088 Hz

Flange:

The flangers are basic 1-tap dual flangers. Separate LFO controls are provided for each channel. Slight variations between algorithms exist. Some algorithms offer separate left and right feedback controls, while some offer only one for both channels. Also, cross-coupling and high-frequency damping may be offered in some and not in others. Parameters associated with flange control begin with “F” in the parameter name. A general description of flanger functionality can be found in the Flanger section or this book, FXAlgs #154-155.

In addition to the LFO delay taps, some flangers may offer a static delay tap for creating through-zero flange effects. The maximum delay time for this tap is 230ms and is controlled by the FI StatDly parameter. Its level is controlled by the FI StatLvl parameter.

PAGE 1

FI Tempo	System; 1 to 255 BPM	FI HF Damp	16 to 25088 Hz
FI Rate	0.01 to 10.00 Hz		
FI Xcurs L	0 to 230 ms	FI Xcurs R	0 to 230 ms
FI Delay L	0 to 230 ms	FI Delay R	0 to 230 ms
FI Fdbk L	-100 to 100%	FI Fdbk R	-100 to 100%
FI Phase L	0 to 360 deg	FI Phase R	0 to 360 deg

PAGE 2

FI HF Damp	16 to 25088 Hz
FI Xcouple	0 to 100%
FI StatDly	0 to 230 ms
FI StatLvl	-100 to 100%

Delay:

The Delay is a basic tempo based dual channel delay with added functionality, including image shifting and high-frequency damping. Separate left and right controls are generally provided for delay time and feedback. Parameters associated with a delay effect in a combination algorithm begin with “Dly”.

The delay length for each channel is determined by Dly Tempo, expressed in beats per minute (BPM), and the delay length (Dly Time L and Dly Time R) of each channel is expressed in beats (bts). The tempo alters both channel delay lengths together. With the tempo in beats per minute and delay lengths in beats, you can calculate the length of a delay in seconds as $\text{beats} / \text{tempo} * 60$ (sec/min). Since KDFX has a limited amount of delay memory available (usually 1.5 seconds for these delays), selecting slow tempos and/or long delay lengths may cause you to run out of delay memory. At this point, each delay will pin at its maximum possible time. Because of this, when you slow down the tempo, you may find the delays lose their sync.

Delay regeneration is controlled by Dly Fdbk. In some combinations, separate left and right feedback controls are provided, while in others there is a single control for both channels.

Dly Image and Dly HFDamp are just like the HFDamp and Image parameters found in other algorithms. Not all delays in combination algorithms will have both of these parameters.

Combination Algorithms [“+”]

Dly Time L	0 to 32 bts	Dly Time R	0 to 32 bts
Dly Fdbk L	-100 to 100%	Dly Fdbk R	-100 to 100%
Dly HFDamp	0 to 32 bts	Dly Image	-100 to 100%

Dly Time L, Dly Time R The delay lengths of each channel in beats. The duration of a beat is specified with the Tempo parameter. The delay length in seconds is calculated as beats/tempo * 60 (sec/min).

Dly Fdbk L, Dly Fdbk R The amount of the output of the effect that is fed back to the input.

Dly HFDamp Controls the cutoff frequency of a 1 pole (6dB/oct slope) lowpass filter in the feedback path. The filter is heard when either Dly Fdbk or LsrCntour is used.

Dly Image This parameter controls the amount of image shifting during each feedback regeneration, and is heard only when Dly Fdbk is used. Small positive values shift the image to the right, while small negative values shift to the left. Larger values tend to shift the image so far that the image gets scrambled, and in some cases create ambience.

Combination 4-Tap:

Combination 4-Tap is a tempo based 4 tap delay with feedback used in combination algorithms. Parameters associated with the 4 tap effect start with “4T”. The control over the feedback tap and individual output taps is essentially the same as the 4-Tap Delay BPM algorithm, with the exception that the delay times will pin at the maximum delay time instead of automatically cutting their times in half. For more information, see the section on 4-Tap Delay BPM of this book, FXAlg #132.

PAGE 1

4T Tempo	System; 1 to 255 BPM
4T LoopLen	0 to 8 bts
4T FB Lvl	-100 to 100%

PAGE 2:

Tap1 Delay	0 to 8 bts	Tap3 Delay	0 to 8 bts
Tap1 Level	-100 to 100%	Tap3 Level	-100 to 100%
Tap1 Bal	-100 to 100%	Tap3 Bal	-100 to 100%
Tap2 Delay	0 to 8 bts	Tap4 Delay	0 to 8 bts
Tap2 Level	-100 to 100%	Tap4 Level	-100 to 100%
Tap2 Bal	-100 to 100%	Tap4 Bal	-100 to 100%

Reverb:

The reverbs offered in these combination effects is MiniVerb. See FXAlg #1 in this book for information about the parameters. Parameters associated with this reverb begin with “Rv”.

		Rv Type	Hall1
		Rv Time	0.5 to 30.0 s; Inf
Rv DiffScl	0.00 to 2.00x	Rv Density	0.00 to 4.00x
Rv SizeScl	0.00 to 4.00x	Rv HF Damp	16 to 25088 Hz
Rv PreDlyL	0 to 620 ms	Rv PreDlyR	0 to 620 ms

Pitcher:

The pitchers offered in these effects are the same as that found in its standalone version. Review the Pitcher section of this book, FXAlg #908, for more information. Parameters associated with this effect begin with “Pt”.

Pt Pitch	C-1 to G9
Pt Offset	-12.0 to 12.0 ST
Pt Odd Wts	-100 to 100%
Pt PairWts	-100 to 100%
Pt 1/4 Wts	-100 to 100%
Pt 1/2 Wts	-100 to 100%

Configurable Combination Algorithms [“◊”]

FXAlg #702 — Chorus◊4Tap
FXAlg #704 — Chorus◊Reverb
FXAlg #705 — Chorus◊LasrDly
FXAlg #708 — Flange◊4Tap
FXAlg #710 — Flange◊Reverb
FXAlg #711 — Flange◊LasrDly
FXAlg #712 — Flange◊Pitcher
FXAlg #713 — Flange◊Shaper
FXAlg #717 — LasrDly◊Reverb
FXAlg #718 — Shaper◊Reverb

A family of re-configurable combination effect algorithms

Allocation Units: 2

Signal Routing

Each of these combination algorithms offer two separate effects combined with a flexible signal-routing mechanism. This mechanism allows the two effects to either be in series bi-directionally or in parallel. This is done by first designating one effect “A”, and the other “B” where the output of effect A is always wired to effect B. A and B are assigned with the A->B cfg parameter. For example, when A->B cfg is set to “Ch->Dly”, then effect A is the chorus, and effect B is the delay, and the output of the chorus is wired to the input of the delay. The amount of effect A fed into effect B is controlled by the A/Dry->B parameter. This controls the balance between effect A output, and the algorithm dry input signal fed into effect B behaving much like a wet/dry mix. When set to 0%, only the dry signal is fed into B allowing parallel effect routing. At 100%, only the A output is fed into B, and at 50%, there is an equal mix of both. For an example of signal flow in the Chor<>4Tap algorithm, see the figure on the next page.

Both effect A and B outputs are mixed at the algorithm output to become the wet signal. These mix levels are controlled with the two parameters that begin with “Mix”. These allow only one or both effect outputs to be heard. Negative mix amounts polarity-invert the signal which can change the character of each effect when mixed together or with the dry signal. The Wet/Dry parameter adjusts the balance between the sum of both effects determined by the Mix parameters, and the input dry signal. Negative Wet/Dry values polarity-invert the summed wet signal relative to dry.

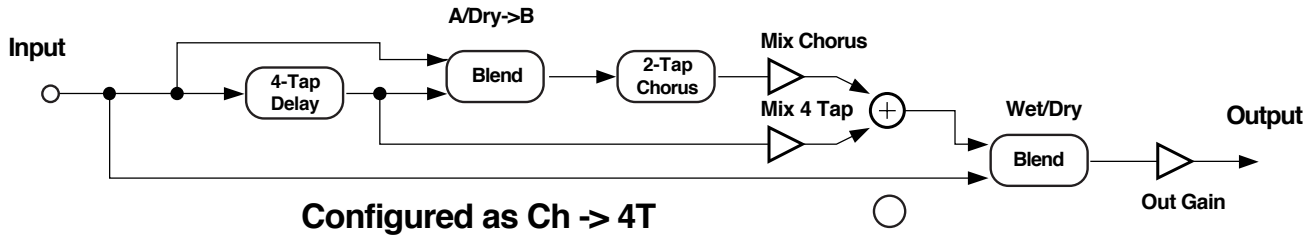

Configured as Ch -> 4T

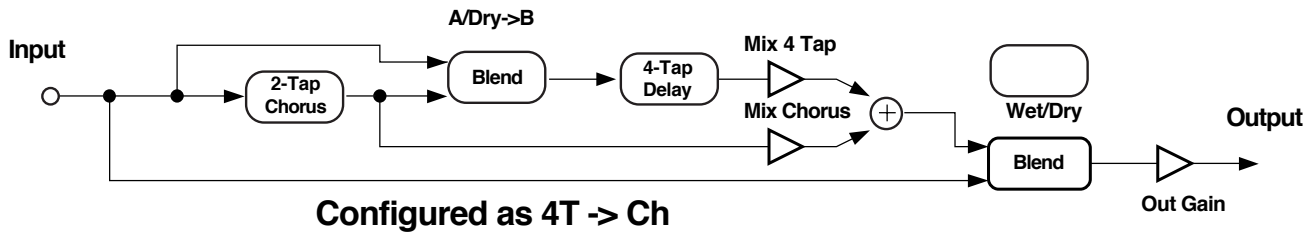

Configured as 4T -> Ch

Algorithm 702, Chor<->4Tap, when A->B cfg is set to (top) “Ch->4T” and (bottom) “4T->Ch”.

Bi-directional Routing:

Wet/Dry	-100 to 100%	Out Gain	Off; -79.0 to 24.0 dB
Mix Effect	-100 to 100%		
Mix Effect	-100 to 100%		
A->B cfg	EffectA>EffectB	A/Dry->B	0 to 100%

Mix Effect

Adjusts the amount of each effect that is mixed together as the algorithm wet signal. Negative values polarity-invert that particular signal.

A->B cfg

This parameter controls the order of the effects routing. The output of effect A is wired into the input of effect B. So, when set to Ch->4T for example, effect A is chorus, and effect B is 4-tap. This is used in conjunction with the A/Dry->B parameter.

A/Dry->B

This parameter controls how much of the A effect is mixed with dry and fed into the B effect. A and B are determined by the A->B cfg parameter. This works like a wet/dry mix, where 0% is completely dry and 100% is effect A only.

Individual Effect Components

Configurable Chorus and Flange:

The configurable chorus and flange have 2 moving delay taps per channel. Parameters associated with chorus control begin with “Ch” in the parameter name, and those associated with flange begin with “Fl”. General descriptions of chorus and flange functionality can be found in the Chorus (FXAlg #150) or Flange (FXAlg #154) sections of this book.

Since these effects have 2 taps per channel, control over four LFOs is necessary with a minimum number of user parameters (Fig. 1). This is accomplished by offering two sets of LFO controls with three user interface modes: Dual1Tap, Link1Tap, or Link2Tap. These are selectable with the LFO cfg parameter and affect the functionality of the two sets of rate, depth and delay controls (and also phase and feedback controls for the flange). Each parameter is labeled with a 1 or a 2 in the parameter name to indicate to which control set it belongs. Control set 1 consists of controls whose name ends with a 1, and control set 2 consists of controls whose name ends with a 2.

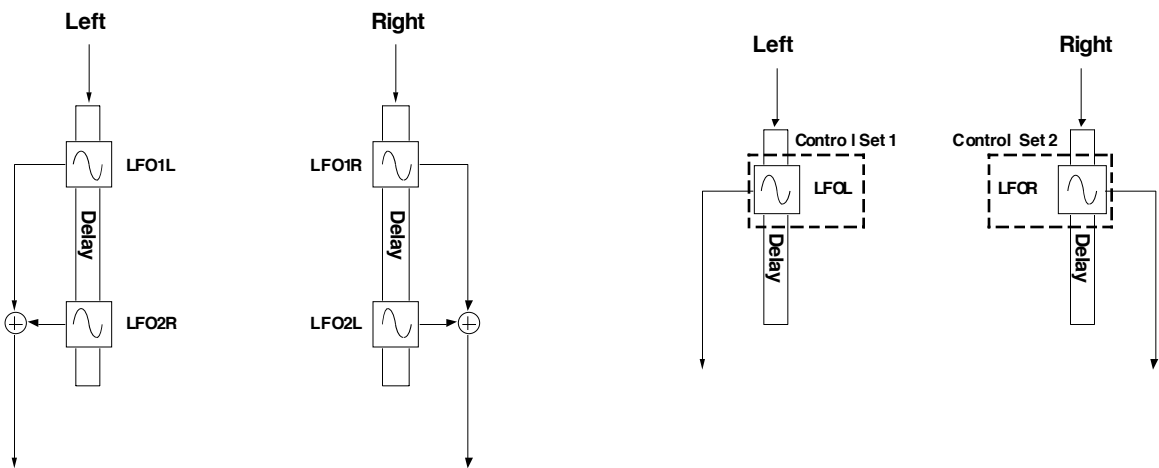

Fig. 1 — LFO delay taps in the configurable chorus and flange **Fig. 2 — LFO control in Dual1Tap mode**

In Dual1Tap mode (Fig. 2), each control set independently controls one tap in each channel. This is useful for dual mono applications where separate control over left and right channels is desired. Control set 1 controls the left channel, and control set 2 controls the right channel. The second pair of moving delay taps are disabled in this mode. LRPhase is unpredictable unless both rates are set to the same speed. Then, the phase value is accurate only after the LFOs are reset. LFOs can be reset by either changing the LFO cfg parameter, or loading in the algorithm by selecting a preset or studio that uses it. For user-friendly LRPhase control, use either the Link1Tap or Link2Tap modes.

In Link1Tap mode (Fig. 3), control set 1 controls 1 tap in both the left and right channels. Control set 2 has no effect, and the second pair of LFO delay taps are disabled. This mode is optimized for an accurate LRPhase relationship between the left and right LFOs.

In Link2Tap mode (Fig. 4), control set 1 controls the first left and right pair of LFOs, while control set 2 controls the second pair. This mode uses all 4 LFOs for a richer sound, and is optimized for LRPhase relationships. Each of the 2 taps per channel are summed together at the output, and the Fdbk parameters control the sum of both LFO taps on each channel fed back to the input.

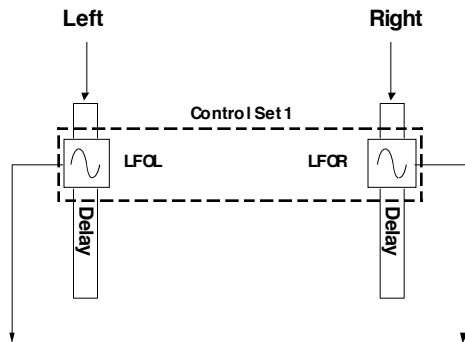

Fig. 3 — LFO control in Link1Tap mode

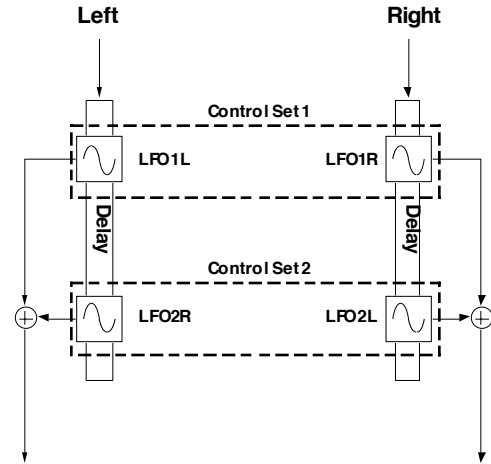

Fig. 4 — LFO control in Link2Tap mode

In addition to the LFO delay taps, the flange offers a static delay tap for creating through-zero flange effects. The maximum delay time for this tap is 230ms and is controlled by the FI StatDly parameter. Its feedback amount is controlled by the FI StatFB. Separate mix levels for the LFO taps and the static tap are then controlled by the FI StatLvl and FI LFO Lvl controls. The feedback and level controls can polarity-invert each signal by setting them to negative values.

Chorus:

Ch LFO cfg	Dual1Tap...	Ch LRPhase	0 to 360 deg
Ch Rate 1	0.01 to 10.00 Hz	Ch Rate 2	0.01 to 10.00 Hz
Ch Depth 1	0.0 to 100 ct	Ch Depth 2	0.0 to 100 ct
Ch Delay 1	0 to 1000 ms	Ch Delay 2	0 to 1000 ms
Ch Fdbk L	-100 to 100%	Ch Fdbk R	-100 to 100%
Ch Xcouple	0 to 100%	Ch HF Damp	16 to 25088 Hz

Flange (PAGE 1):

FI LFO cfg	Dual1Tap...	FI LRPhase	0 to 360 deg
FI Rate 1	0.01 to 10.00 Hz	FI Rate 2	0.01 to 10.00 Hz
FI Xcurs 1	0 to 230 ms	FI Xcurs 2	0 to 230 ms
FI Delay 1	0 to 1000 ms	FI Delay 2	0 to 1000 ms
FI Fdbk 1	-100 to 100%	FI Fdbk 2	-100 to 100%
FI Phase 1	0 to 360 deg	FI Phase 2	0 to 360 deg

Flange (PAGE 2):

FI HF Damp	16 to 25088 Hz
FI Xcouple	0 to 100%
FI StatDly	0 to 230 ms
FI StatFB	-100 to 100%
FI StatLvl	-100 to 100%
FI LFO Lvl	-100 to 100%

<u>Ch LFO cfg</u>	Sets the user interface mode for controlling each of the 4 chorus LFOs.
<u>Ch LRPhase</u>	Controls the relative phase between left channel LFOs and right channel LFOs. In Dual1Tap mode, however, this parameter is accurate only when Ch Rate 1 and Ch Rate 2 are set to the same speed, and only after the Ch LFO cfg parameter is moved, or the algorithm is called up.
<u>Ch Fdbk L, Ch Fdbk R</u>	These control the amount that the output of the chorus is fed back into the input.
<u>FI LFO cfg</u>	Sets the user interface mode for controlling each of the 4 flange LFOs.
<u>FI LRPhase</u>	Controls the relative phase between left channel LFOs and right channel LFOs. In Dual1Tap mode, however, this parameter is accurate only when FI Rate 1 and FI Rate 2 are set to the same speed, and only after the FI LFO cfg parameter is moved, or the algorithm is called up.
<u>FI Phase 1, FI Phase 2</u>	These adjust the phase relationship between the corresponding LFO and the internal beat clock.

Laser Delay:

Laser Delay is a tempo based delay with added functionality, including image shifting, cross-coupling, high frequency damping, low frequency damping, and a LaserVerb element. Separate left and right controls are provided for delay time, feedback, and laser controls. Parameters associated with Laser Verb in a combination algorithm begin with “Dly” or “Lsr”.

The delay length for each channel is determined by Dly Tempo, expressed in beats per minute (BPM), and the delay length (Dly Time L and Dly Time R) of each channel is expressed in beats (bts). The tempo alters both channel delay lengths together. With the tempo in beats per minute and delay lengths in beats, you can calculate the length of a delay in seconds as $\text{beats} / \text{tempo} * 60$ (sec/min). Since KDFX has a limited amount of delay memory available (usually 1.5 seconds for Laser Delay), selecting slow tempos and/or long delay lengths may cause you to run out of delay memory. At this point, each delay will pin at its maximum possible time. When you slow down the tempo, you may find the delays lose their sync.

The laser controls perform similarly to those found in LaserVerb (see FXAlg# 911 in this book), and affect the laser element of the effect. The LsrCntour changes the laser regeneration envelope shape. Higher values increase the regeneration amount, and setting it to 0% will disable the Laser Delay portion completely turning the effect into a basic delay. LsrSpace controls the impulse spacing of each regeneration. Low values create a strong initial pitched quality with slow descending resonances, while higher values cause the resonance to descend faster through each regeneration. See the LaserVerb section for more detailed information.

Delay regeneration is controlled collectively by the Dly Fdbk and LsrCntour parameters since the laser element contains feedback within itself. Setting both to 0% defeats all regeneration, including the laser element entirely. Increasing either one will increase regeneration overall, but with different qualities. Dly Fdbk is a feedback control in the classic sense, feeding the entire output of the effect back into the input, with negative values polarity-

inverting the signal. The LsrCntour parameter adds only the Laser Delay portion of the effect, including it’s own regeneration. For the most intense laser-ness, keep Dly Fdbk at 0% while LsrCntour is enabled.

Dly FBImag, Dly Xcouple, Dly HFDamp, and Dly LFDamp are just like those found in other algorithms. Not all Laser Delays in combination algorithms will have all four of these parameters.

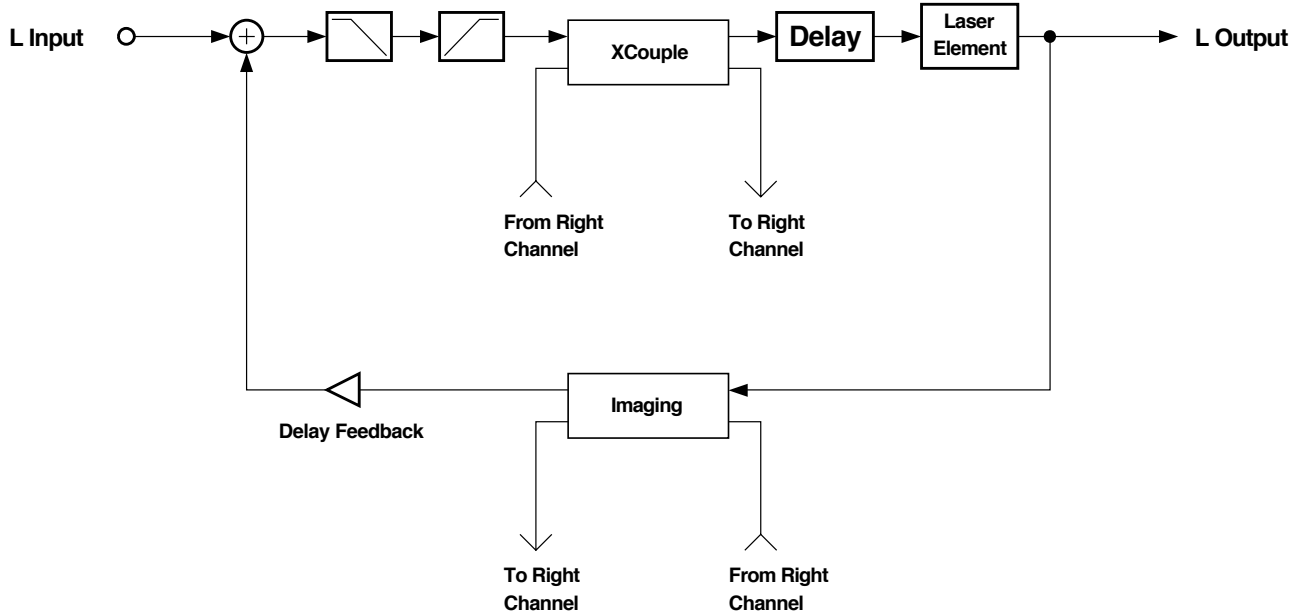

Laser Delay (left channel)

Dly Time L	0 to 6 bts	Dly Time R	0 to 6 bts
Dly Fdbk L	-100 to 100%	Dly Fdbk R	-100 to 100%
Dly HFDamp	0 to 32 bts	Dly FBImag	-100 to 100%
Dly LFDamp	0.10 to 6.00 x	Dly Xcple	0 to 100%
LsrCntourL	0 to 100%	LsrCntourR	0 to 100%
LsrSpace L	0 to 100 samp	LsrSpace R	0 to 100 samp

Dly Time L, Dly Time R The delay lengths of each channel in beats. The duration of a beat is specified with the Tempo parameter. The delay length in seconds is calculated as beats/tempo * 60 (sec/min).

Dly Fdbk L, Dly Fdbk R The amount of the output of the effect that is fed back to the input.

Dly HFDamp Controls the cutoff frequency of a 1 pole (6dB/oct slope) lowpass filter in the feedback path. The filter is heard when either Dly Fdbk or LsrCntour is used.

Dly LFDamp Controls the cutoff frequency of a 1 pole (6dB/oct slope) hipass filter in the feedback path. The filter is heard when either Dly Fdbk or LsrCntour is used.

Dly FBImag This parameter controls the amount of image shifting during each feedback regeneration, and is heard only when Dly Fdbk is used. Small positive values shift the image to the right, while small negative values shift to the left. Larger values tend to shift the image so far that the image gets scrambled, and in some cases create ambience.

Dly Xcple This parameter controls the amount of signal that is swapped between the left and right

Configurable Combination Algorithms [“◇”]

channels through each feedback generation when Dly Fdbk is used. A setting of 0% has no affect. 50% causes equal amounts of signal to be present in both channels causing the image to collapse into a center point source. A setting of 100% causes the left and right channels to swap each regeneration, which is also referred to as “ping-ponging”. The regeneration affects of cross-coupling are not heard when LsrCntour is used by itself.

LsrCntour L, LsrCntour R Controls the overall envelope shape of the laser regeneration. When set to a high value, sounds passing through will start at a high level and slowly decay. As the control value is reduced, it takes some time for the effect to build up before decaying. When the Contour is set to zero, the laser portion is turned off turning regeneration into straight feedback.

LsrSpace L, LsrSpace R Determines the starting pitch of the descending resonance and how fast it descends. See the section on Laser Reverb for more detailed information.

Combination 4-Tap:

Combination 4-Tap is a tempo-based 4-tap delay with feedback used in combination algorithms. Parameters associated with the 4 tap effect start with “4T”. The control over the feedback tap and individual output taps is essentially the same as the 4-Tap Delay BPM algorithm (see FXAlg #132 in this book), with the exception that the delay times will pin at the maximum delay time instead of automatically cutting their times in half. Additionally, the feedback path may also offer cross-coupling, an imager, a hipass filter, and/or a lowpass filter.

PAGE 1

4T LoopLen	0 to 32 bts
4T FB Lvl	-100 to 100%
4T FB Imag	-100 to 100%
4T FB XCpl	0 to 100%
4T HF Damp	16 to 25088 Hz
4T LF Damp	16 to 25088 Hz

PAGE 2

Tap1 Delay	0 to 32 bts	Tap3 Delay	0 to 32 bts
Tap1 Level	-100 to 100%	Tap3 Level	-100 to 100%
Tap1 Bal	-100 to 100%	Tap3 Bal	-100 to 100%
Tap2 Delay	0 to 32 bts	Tap4 Delay	0 to 32 bts
Tap2 Level	-100 to 100%	Tap4 Level	-100 to 100%
Tap2 Bal	-100 to 100%	Tap4 Bal	-100 to 100%

4T FB Imag This parameter controls the amount of image shifting during each feedback regeneration. Small positive values shift the image to the right, while small negative values shift to the left. Larger values tend to shift the image so far that the image gets scrambled, and in some cases create ambience.

4T FB Xcpl This parameter controls the amount of signal that is swapped between the left and right channels through each feedback regeneration. A setting of 0% has no affect. 50% causes equal amounts of signal to be present in both channels causing the image to collapse into a center point source. A setting of 100% causes the left and right channels to swap each regeneration, which is also referred to as “ping-ponging”.

4T LoopLen, 4T Tempo, 4T FB Lvl, Tapn Delay, Tapn Level, Tapn Bal Refer to 4-Tap Delay BPM documentation.

Reverb:

The reverbs offered in these combination effects is MiniVerb. Information about it can be found in the MiniVerb documentation (FXAlg#1 in this book). Parameters associated with this reverb begin with “Rv”.

Rv Type	Hall1		
Rv Time	0.5 to 30.0 s; Inf		
Rv DiffScl	0.00 to 2.00x	Rv Density	0.00 to 4.00x
Rv SizeScl	0.00 to 4.00x	Rv HF Damp	16 to 25088 Hz
Rv PreDlyL	0 to 620 ms	Rv PreDlyR	0 to 620 ms

Pitcher:

The pitchers offered in these effects are the same as that found in its standalone version. Review the Pitcher section of this book, FXAlg #908, for more information. Parameters associated with this effect begin with “Pt”.

Pt Pitch	C-1 to G9
Pt Offset	-12.0 to 12.0 ST
Pt Odd Wts	-100 to 100%
Pt PairWts	-100 to 100%
Pt 1/4 Wts	-100 to 100%
Pt 1/2 Wts	-100 to 100%

Shaper:

The shaper offered in these combination effects have the same qualities as those found in VAST. Refer to the section on shapers in the *K2500 Performance Guide* for an overview. Parameters associated with this effect begin with “Shp”.

This KDFX shaper also offers input and output 1 pole (6dB/oct) lowpass filters controlled by the Shp Inp LP and Shp Out LP respectively. There is an additional output gain labeled Shp OutPad to compensate for the added gain caused by shaping a signal.

Shp Inp LP	16 to 25088 Hz
Shp Amt	0.10 to 6.00 x
Shp Out LP	16 to 25088 Hz
Shp OutPad	Off; -79.0 to 0.0 dB

Shp Inp LP

Adjusts the cutoff frequency of the 1 pole (6dB/oct) lowpass filter at the input of the shaper.

Shp Out LP

Adjusts the cutoff frequency of the 1 pole (6dB/oct) lowpass filter at the output of the shaper.

Shp Amount

Adjusts the shaper intensity. This is exactly like the one in VAST.

Shp OutPad

Adjusts the output gain at the output of the shaper to compensate for added gain caused by the shaper.

FXAlg #714: Quantize+Flange

Digital quantization followed by flanger.

Allocation Units: 1

Digital audio engineers will go to great lengths to remove, or at least hide the effects of digital quantization distortion. In Quantize+Flange we do quite the opposite, making quantization an in-your-face effect. The quantizer will give your sound a dirty, grungy, perhaps industrial sound. As you've already gathered from the name, the quantization is followed by a flanger. Quantize+Flange is a stereo effect.

Quantization distortion is a digital phenomenon caused by having only a limited number of bits with which to represent signal amplitudes (finite precision). You are probably aware that a bit is a number which can have only one of two values: 0 or 1. When we construct a data or signal word out of more than one bit, each additional bit will double the number of possible values. For example a two-bit number can have one of four different values: 00, 01, 10 or 11. A three-bit number can take one of eight different values, a four-bit number can take one of sixteen values, etc. The 18 bits of the K2500's digital-to-analog converter (DAC) represents 262,144 different amplitude levels (2^{18}). Let's take a look at how finite precision of digital words affects audio signals. The figures following are plots of a decaying sine wave with varying word lengths.

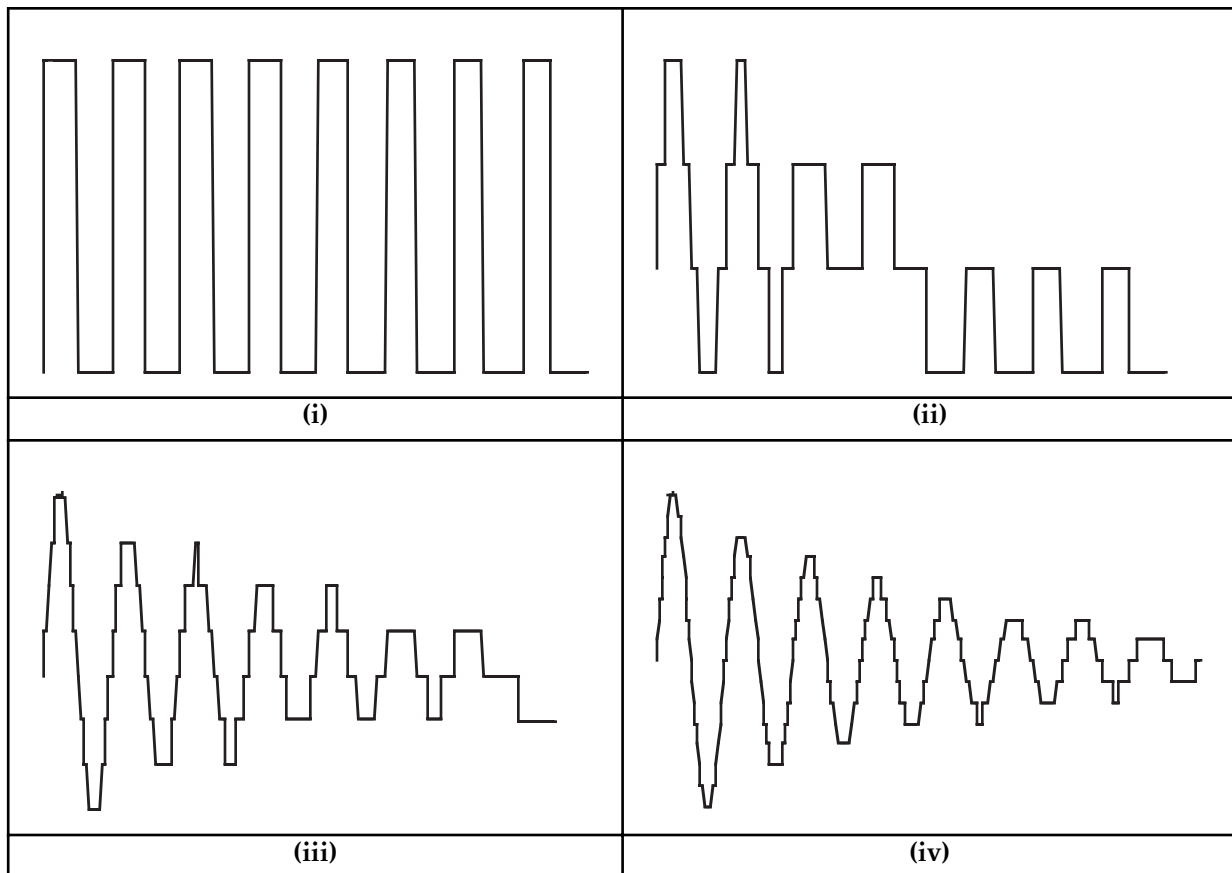

A decaying sine wave represented with different word lengths: (i) 1-bit, (ii) 2-bit, (iii) 3-bit, (iv) 4-bit.

Clearly a one-bit word gives a very crude approximation to the original signal while four bits is beginning to do a good job of reproducing the original decaying sine wave. When a good strong signal is being quantized (its word length is being shortened), quantization usually sounds like additive noise. But notice that as the signal decays in the above figures, fewer and fewer quantization levels are being exercised until, like the one bit example, there are only two levels being toggled. With just two levels, your signal has become a square wave.

Controlling the bit level of the quantizer is done with the DynamRange (dynamic range) parameter. At 0 dB we are at a one-bit word length. Every 6 dB adds approximately one bit, so at 144 dB, the word length is 24 bits. The quantizer works by cutting the gain of the input signal, making the lowest bits fall off the end of the word. The signal is then boosted back up so we can hear it. At very low DynamRange settings, the step from one bit level to the next can become larger than the input signal. The signal can still make the quantizer toggle between bit level whenever the signal crosses the zero signal level, but with the larger bit levels, the output will get louder and louder. The Headroom parameter prevents this from happening. When the DynamRange parameter is lower than the Headroom parameter, no more signal boost is added to counteract the cut used to quantize the signal. Find the DynamRange level at which the output starts to get too loud, then set Headroom to that level. You can then change the DynamRange value without worrying about changing the signal level. Headroom is a parameter that you set to match your signal level, then leave it alone.

At very low DynamRange values, the quantization becomes very sensitive to dc offset. It affects where your signal crosses the digital zero level. A dc offset adds a constant positive or negative level to the signal. By adding positive dc offset, the signal will tend to quantize more often to a higher bit level than to a lower bit level. In extreme cases (which is what we're looking for, after all), the quantized signal will sputter, as it is stuck at one level most of the time, but occasionally toggles to another level.

A flanger with one LFO delay tap and one static delay tap follows the quantizer. See the section in this book on multi-tap flangers (FXAlgs #154-155) for a detailed explanation of how the flanger works.

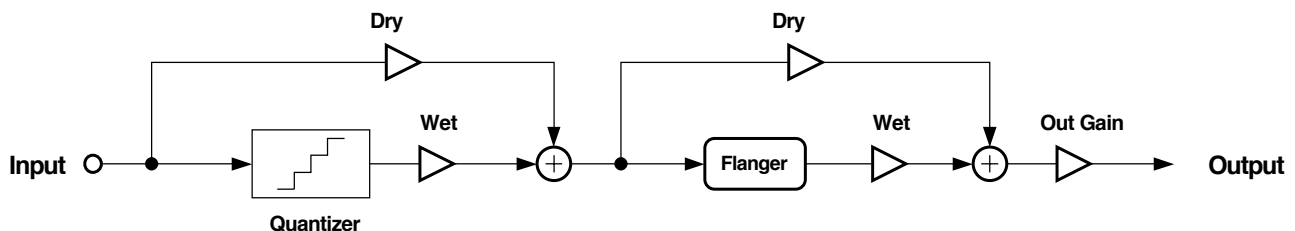

Block diagram of one channel of Quantize+Flange.

Quant W/D is a wet/dry control setting the relative amount of quantized (wet) and not quantized (dry) signals being passed to the flanger. The Flange W/D parameter similarly controls the wet/dry mix of the flanger. The dry signal for the flanger is the wet/dry mix output from the quantizer.

Parameters:

PAGE 1

In/Out	In or Out	Out Gain	Off, -79.0 to 24.0 dB
Quant W/D	0 to 100%	DynamRange	0 to 144 dB
Flange W/D	-100 to 100%	dc Offset	-79.0 to 0.0 dB
		Headroom	0 to 144 dB

PAGE 2

FI Tempo	System, 1 to 255 BPM	FI Fdbk	-100 to 100%
FI Period	0 to 32 bts		
FI L Phase	0.0 to 360.0 deg	FI R Phase	0.0 to 360.0 deg
FI StatLvl	-100 to 100%	FI LFO Lvl	-100 to 100%

PAGE 3

FIStatDlyC	0.0 to 230.0 ms	FI Xcurs C	0.0 to 230.0 ms
FIStatDlyF	-127 to 127 samp	FI Xcurs F	-127 to 127 samp
		FI Delay C	0.0 to 230.0 ms
		FI Delay F	-127 to 127 samp

- In/Out When set to "In", the quantizer and flanger are active; when set to "Out", the quantizer and flanger are bypassed.
- Out Gain The overall gain or amplitude at the output of the effect.
- Quant W/D The relative amount of quantized (wet) to unaffected (dry) signal passed to the flanger. At 100%, you hear only quantized signal pass to the flanger.
- Flange W/D The relative amount of input signal (from the quantizer) and flanger signal that is to appear in the final effect output mix. When set to 0%, the output is taken only from the quantizer (dry). When set to 100%, the output is all wet. Negative values polarity-invert the wet signal.
- DynamRange The digital dynamic range controls signal quantization, or how many bits to remove from the signal data words. At 0 dB the hottest of signals will toggle between only two bit (or quantization) levels. Every 6 dB added doubles the number of quantization levels. If the signal has a lot of headroom (available signal level before digital clipping), then not all quantization levels will be reached.
- Headroom When the signal has a lot of headroom (available signal level before digital clipping), turning down DynamRange can cause the amplitude of adjacent quantization levels to exceed the input signal level. This causes the output to get very loud. Set Headroom to match the amount of digital signal level still available (headroom). This is easily done by finding the DynamRange level at which the signal starts getting louder and matching Headroom to that value.
- dc Offset Adds a positive dc Offset to the input signal. By adding dc Offset, you can alter the position where digital zero is with respect to your signal. At low DynamRange settings, adding dc Offset can make the output "sputter". dc Offset is expressed in decibels (dB) relative to full scale digital.
- FI Tempo Basis for the rates of the LFOs, as referenced to a musical tempo in bpm (beats per minute). When this parameter is set to "System", the tempo is locked to the internal sequencer tempo or to incoming MIDI clocks. When it is set to "System", sources (FUNs, LFOs, ASRs etc.) will have no effect on the Tempo parameter.
- FI Period Sets the LFO rate based on the Tempo determined above: the number of beats corresponding to one period of the LFO cycle. For example, if the FI Period is set to "4", the LFOs will take four beats to pass through one oscillation, so the LFO rate will be 1/4th of the Tempo setting. If it is set to "6/24" (=1/4), the LFO will oscillate four times as fast as the Tempo. At "0", the LFOs stop oscillating and their phase is undetermined (wherever they stopped).
- FI Fdbk The level of the flanger feedback signal into the flanger delay line. The feedback signal is taken from the LFO delay tap. Negative values polarity-invert the feedback signal.

<u>Fl L/R Phase</u>	The phase angles of the left and right LFOs relative to each other and to the system tempo clock, if turned on (see Fl Tempo). In all other respects the right and left channels are symmetric. For example, if one LFO is set to 0° and another is set to 180°, then when one LFO delay tap is at its shortest, the other will be at its longest. If the system tempo clock is on, the LFOs are synchronized to the clock with absolute phase. A phase of 0° will put an LFO tap at the center of its range and its lengthening. Using different phase angles for left and right, the stereo sound field is broken up and a stereo image becomes difficult to spatially locate. The effect is usually described as “phasey”. It tends to impart a greater sense of motion.
<u>Fl StatLvl</u>	The level of the flanger static delay tap. Negative values polarity-invert the signal. Setting the tap level to 0% turns off the delay tap.
<u>Fl LFO Lvl</u>	The level of the flanger LFO modulated delay tap. Negative values polarity-invert the signal. Setting the tap level to 0% turns off the delay tap.
<u>FlStatDlyC</u>	The nominal length of the flanger static delay tap from the delay input. The name suggests the tap is stationary, but it can be connected to a control source such as a data slider, a ribbon, or a V.A.S.T. function to smoothly vary the delay length. The range for all delays and excursions is 0 to 230 ms, but for flanging the range 0 to 5 ms is most effective.
<u>FlStatDlyF</u>	A fine adjustment to the flanger static delay tap length. The resolution is one sample.
<u>Fl Xcurs C</u>	The flanger LFO excursion controls set how far the LFO modulated delay taps can move from the center of their ranges. The total range of the LFO sweep is twice the excursion. If the excursion is set to 0, the LFO does not move and the tap behaves like a simple delay line set to the minimum delay. The range for all delays and excursions is 0 to 230 ms, but for flanging the range 0 to 5 ms is most effective. This parameter is a coarse adjustment for the excursion.
<u>Fl Xcurs F</u>	A fine adjustment for the flanger LFO excursions. The resolution is one sample.
<u>Fl Delay C</u>	The minimum delay for the flanger LFO modulated delay taps. The maximum delay will be the minimum plus twice the excursion. The range for all delays and excursions is 0 to 230 ms, but for flanging the range 0 to 5 ms is most effective. This parameter is a coarse adjustment for the delay.
<u>Fl Delay F</u>	A fine adjustment to the minimum flanger delay tap lengths. The resolution is one sample.

FXAlg #715: Dual MovDelay • FXAlg #716: Quad MovDelay

Generic dual-mono moving delay lines *Allocation Units: Dual MovDelay 1; Quad MovDelay 2*

Each of these two algorithms offers generic monaural moving delay lines in a dual mono algorithm. Each separate moving delay can be used as a flanger, chorus, or static delay line selectable by the LFO Mode parameter. Both flavors of chorus pitch envelopes are offered: ChorTri for triangle, and ChorTrap for trapezoidal pitch shifting. Refer to the Chorus section of this book (FXAlgs #150-153) for more information on these envelope shapes.

Each moving delay offers control over center delay length, LFO excursion, LFO rate, feedback, and high frequency damping. The delay length, in milliseconds, is the center of LFO excursion. LFO excursion is controlled by the LFO Dpth parameter in percent. LFO Depth is an arbitrary value, and is the percentage of available excursion. When using LFO Mode Flange, this adjusts the range that the LFO will move the delay tap. When in LFO Mode ChorTri or ChorTrap, this controls the maximum pitch depth caused by the moving delay tap, and is constant regardless of LFO Rate.

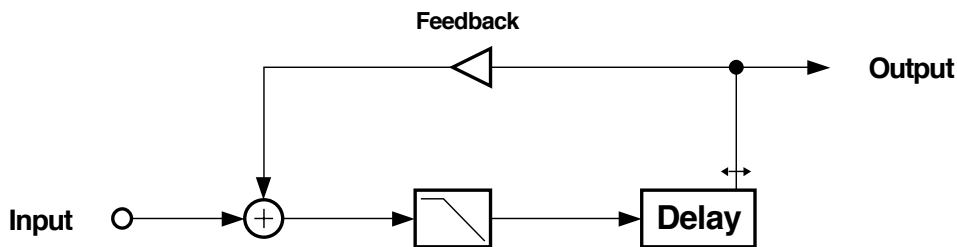

Generic monaural moving delay line

Both of these algorithms are configured with dual mono control meaning the left and right channels are set up to be completely independent of each other. In Dual MovDelay, each channel has a single moving delay segment. Parameters beginning with "L" and "R" control the left and right input channels respectively.

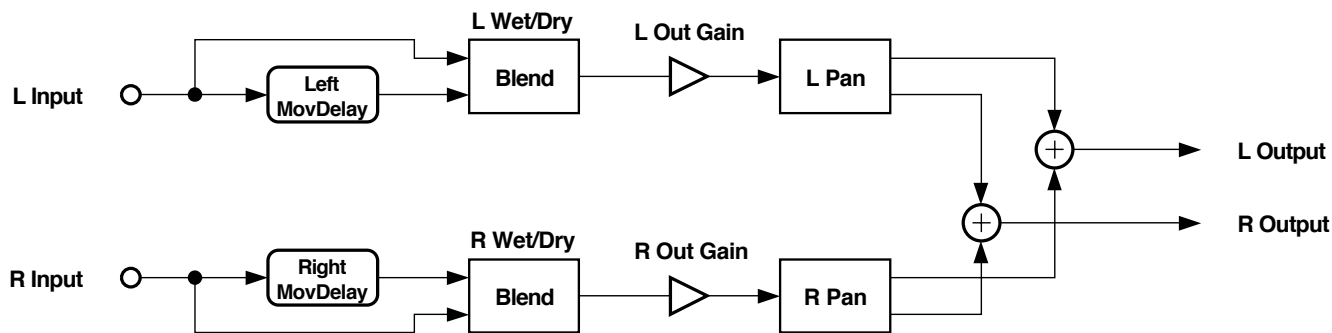

Signal flow of Dual MovDelay

In Quad MovDelay, there are 2 moving delay elements per channel distinguishable by parameters beginning with "L1", "L2", "R1", and "R2". The second moving delay on each channel is fed with a mix of the first delays and the input dry signal for that particular channel. These mixes are controlled by L1/Dry->L2 and R1/Dry->R2. Each of the four moving delays have separate Mix and Pan levels. The input dry signal for each channel can also be panned. The Wet/Dry parameter controls the ratio between the sum of both moving delay elements on that channel regardless of pan position, and the input dry signal. Out Gain, like Wet/Dry, adjusts the output level for each channel regardless of pan position.

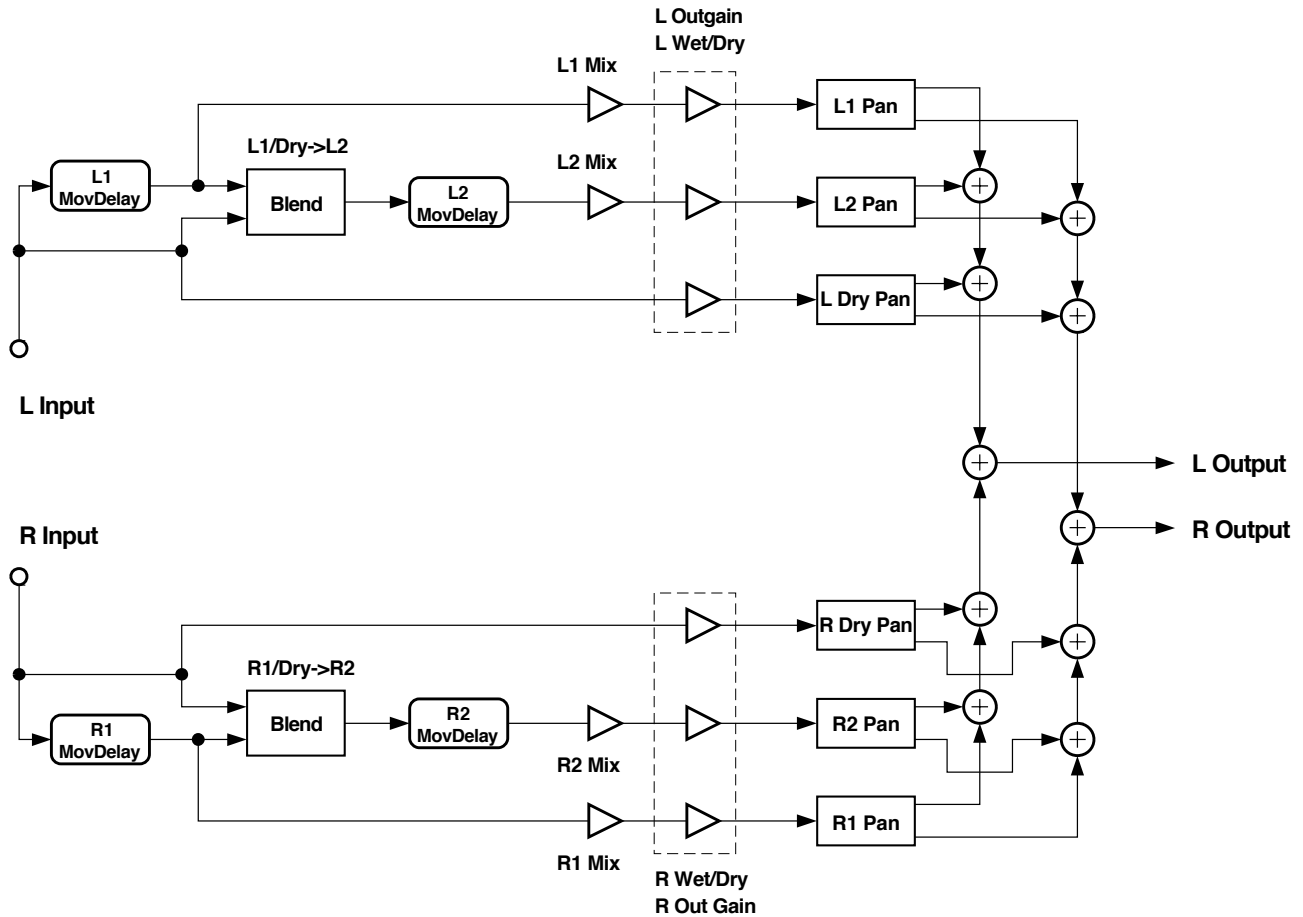

Signal flow of Quad MovDelay

Parameters (Dual MovDelay):

PAGE 1

L Wet/Dry	0 to 100%wet	R Wet/Dry	0 to 100%wet
L Out Gain	Off; -79.0 to 24.0 dB	R Out Gain	Off; -79.0 to 24.0 dB
L Pan	-100 to 100%	R Pan	-100 to 100%

PAGE 2

L Delay	0.0 to 1000.0 ms	R Delay	0.0 to 1000.0 ms
L LFO Mode	Flange, ...	R LFO Mode	Flange, ...
L LFO Rate	0.00 to 10.00 Hz	R LFO Rate	0.00 to 10.00 Hz
L LFO Dpth	0.0 to 200.0%	R LFO Dpth	0.0 to 200.0%
L Feedback	-100 to 100%	R Feedback	-100 to 100%
L HF Damp	16 to 25088 Hz	R HF Damp	16 to 25088 Hz

Parameters (Quad MovDelay):

PAGE 1

L Wet/Dry	-100 to 100%wet	R Wet/Dry	-100 to 100%wet
L Out Gain	Off; -79.0 to 24.0 dB	R Out Gain	Off; -79.0 to 24.0 dB
L1 Mix	-100 to 100%	R1 Mix	-100 to 100%
L2 Mix	-100 to 100%	R2 Mix	-100 to 100%

PAGE 2

L1 Pan	-100 to 100%	R1 Pan	-100 to 100%
L2 Pan	-100 to 100%	R2 Pan	-100 to 100%
L Dry Pan	-100 to 100%	L Dry Pan	-100 to 100%
L1/Dry->L2	0 to 100%	L1/Dry->L2	0 to 100%

PAGE 3

L1 Delay	0.0 to 1000.0 ms	L2 Delay	0.0 to 1000.0 ms
L1 LFO Mode	Flange, ...	L2 LFO Mode	Flange, ...
L1 LFO Rate	0.00 to 10.00 Hz	L2 LFO Rate	0.00 to 10.00 Hz
L1 LFO Dpth	0.0 to 200.0%	L2 LFO Dpth	0.0 to 200.0%
L1 Feedback	-100 to 100%	L2 Feedback	-100 to 100%
L1 HF Damp	16 to 25088 Hz	L2 HF Damp	16 to 25088 Hz

PAGE 4

R1 Delay	0.0 to 1000.0 ms	R2 Delay	0.0 to 1000.0 ms
R1 LFO Mode	Flange, ...	R2 LFO Mode	Flange, ...
R1 LFO Rate	0.00 to 10.00 Hz	R2 LFO Rate	0.00 to 10.00 Hz
R1 LFO Dpth	0.0 to 200.0%	R2 LFO Dpth	0.0 to 200.0%
R1 Feedback	-100 to 100%	R2 Feedback	-100 to 100%
R1 HF Damp	16 to 25088 Hz	R2 HF Damp	16 to 25088 Hz

L Wet/Dry, R Wet/Dry The relative amount of input signal and effected signal that is to appear in the final effect output mix for each input channel. When set to 0%, the output is taken only from the corresponding input (dry) signal. When set to 100%, the output is all wet. Negative values polarity-invert the wet signal.

L Out Gain, R Out Gain The overall gain or amplitude at the output of the effect for each input channel.

- Ln Mix, Rn Mix Adjusts the mix levels for each moving delay circuit. The resulting sum makes up the wet signal. Negative values polarity-invert the signal.
- L Pan, R Pan, Ln Pan, Rn Pan The output panning position of each moving delay circuit. 0% is center; Negative values pan left, while positive values pan right.
- L Dry Pan, R Dry Pan Adjusts the output pan position of the input dry signals. The dry level is controlled with Wet/Dry. 0% pans to center; Negative values pan left while positive values pan right.
- L1/Dry->L2, R1/Dry->R2 Adjusts the input mix into the second pair of moving delay circuits in Quad MovDelay. The value represents a ratio of the output of the first moving delay circuit and the input dry signal. A value of 0% allows only the input dry signal to be fed into the second delay, while a value of 100% only allows the first delay to be fed into the second.
- L Delay, R Delay, Ln Delay, Rn Delay Adjusts the delay time for each moving delay circuit, which is the center of LFO excursion.
- L LFO Mode, R LFO Mode, Ln LFO Mode, Rn LFO Mode Adjusts the LFO excursion type. In Flange mode, the LFO is optimized for flange effects and LFO Dpth adjusts the excursion amount. In ChorTri and ChorTrap modes, the LFO is optimized for triangle and trapezoidal pitch envelopes respectively, and LFO Dpth adjusts the amount of chorus detuning. In Delay mode, the LFO is turned off leaving a basic delay. LFO Rate and LFO Dpth in Delay mode are disabled.
- L LFO Rate, R LFO Rate, Ln LFO Rate, Rn LFO Rate Adjusts the LFO speed for each moving delay circuit.
- L LFO Dpth, R LFO Dpth, Ln LFO Dpth, Rn LFO Dpth In Flange LFO mode, this adjusts an arbitrary LFO excursion amount. In ChorTri and ChorTrap modes, this controls the chorus detune amount. In delay mode, this is disabled.
- L Feedback, R Feedback, Ln Fdbk, Rn Fdbk Adjusts the level of each moving delay circuits output signal fed back into their own inputs. Negative values polarity-invert the feedback signal.
- L HF Damp, R HF Damp, Ln HF Damp, Rn HF Damp Adjusts the cutoff frequency of a 1-pole (6dB/oct) lowpass filter in each moving delay circuit.

FXAlg #720: MonoPitcher+Chor • FXAlg #721: MonoPitcher+Flan

Mono pitcher (filter with harmonically related resonant peaks) algorithm with a chorus or flanger *Allocation Units: 2 (each)*

The mono pitcher algorithm applies a filter which has a series of peaks in the frequency response to the input signal. The peaks may be adjusted so that their frequencies are all multiples of a selectable frequency, all the way up to 24 kHz. When applied to a sound with a noise-like spectrum (white noise, with a flat spectrum, or cymbals, with a very dense spectrum of many individual components), an output is produced which sounds very pitched, since most of its spectral energy ends up concentrated around multiples of a fundamental frequency.

The following graphs show Pt PkSplit going from 0% to 100%, for a Pt Pitch of 1 kHz (approx. C6), and Pt PkShape set to 0.

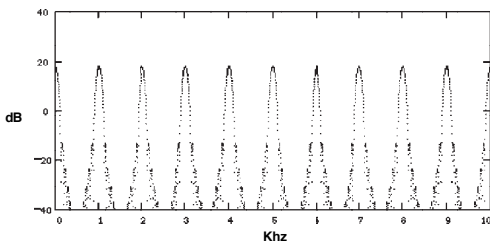

PeakShape = 0
PeakSplit = 0%

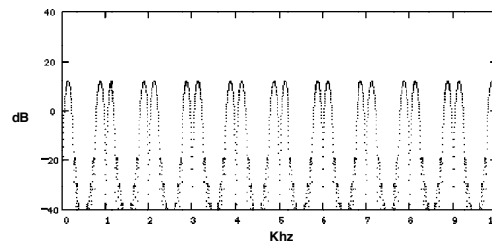

PeakShape = 0
PeakSplit = 25%

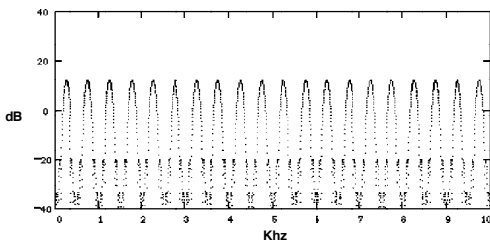

PeakShape = 0
PeakSplit = 50%

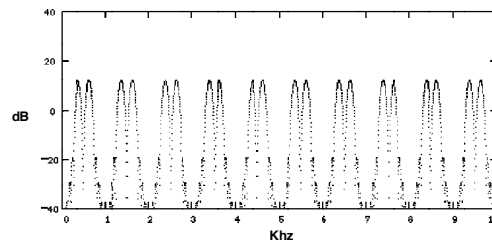

PeakShape = 0
PeakSplit = 75%

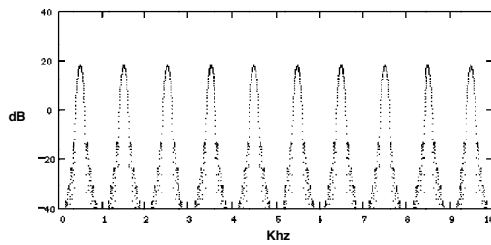

PeakShape = 0
PeakSplit = 100%

Response of Pitcher with different PkSplit settings.

Note that a Pt PkSplit of 100% gives only odd multiples of a fundamental that is one octave down from no splitting. The presence of only odd multiples will produce a hollow sort of sound, like a square wave (which also only has odd harmonics). Curiously enough, at a Pt PkSplit of 50% we also get odd multiples of a frequency that is now two octaves below the original Pitch parameter. In general, most values of PkSplit will give peak positions that are not harmonically related.

The figures below show Pt PkShape of -1.0, 0.0, and 1.0, for a Pitch of C6 and a PkSplit of 0%.

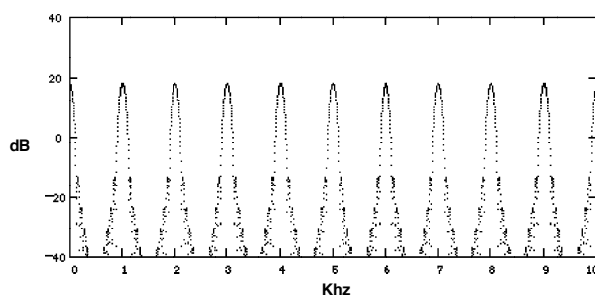

PeakShape = 0
PeakSplit = 0%

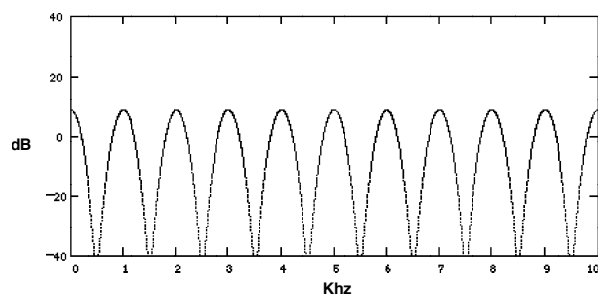

PeakShape = 1.0
PeakSplit = 0%

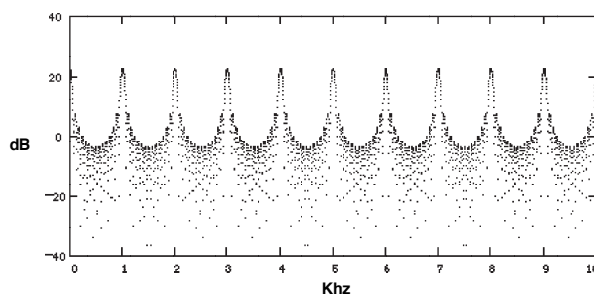

PeakShape = -1.0
PeakSplit = 0%

Response of Pitcher with PkShape settings at 0, -1.0, and 1.0.

Applying Pitcher to sounds such as a single sawtooth wave will tend to not produce much output, unless the sawtooth frequency and the Pitcher frequency match or are harmonically related, because otherwise the peaks in the input spectrum won't line up with the peaks in the Pitcher filter. If there are enough peaks in the input spectrum (obtained by using sounds with noise components, or combining lots of different simple sounds, especially low pitched ones, or severely distorting a simple sound) then Pitcher can do a good job of imposing its pitch on the sound.

Multiple Pitcher algorithms can be run (yes, it takes all of KDFX to get three) to produce chordal output.

At extremely low Pitch settings, the effect begins to sound more like a multi-tap delay, but this can be pretty cool, too.

A vocoder-like effect can be produced, although in some sense it works in exactly an opposite way to a real vocoder. A real vocoder will superimpose the spectrum of one signal (typically speech) onto a musical signal (which has only a small number of harmonically related spectral peaks). Pitcher takes an input such as speech, and then picks out only the components that match a harmonic series, as though they were from a musical note.

Chorus:

The chorus used in FXAlg #720 is a basic dual-channel chorus. Refer to Chorus documentation (FXAlgs #150-153) in this book for more information on the effect.

Configurable Flange:

The flange in FXAlg #721 is a configurable flange. Refer to the section on Flanger (FXAlg #702 and FXAlgs #154-155) in this book for details about this effect.

Parameters (MonoPitcher+Chor):

PAGE 1

Wet/Dry	100 to 100%wet	Out Gain	Off, -79.0 to 24.0 dB
Mix Pitchr	-100 to 100%		
Mix Chorus	-100 to 100%		
Pt/Dry->Ch	0 to 100%		

PAGE 3

Pt Inp Bal	-100 to 100%	Pt Out Pan	-100 to 100%
Pt Pitch	C-1 to G 9	Pt Offset	-12.0 to 12.0 ST
Pt PkSplit	0 to 100%	Pt PkShape	-1.0 to 1.0

ChPtchEnvL	Triangle or trapezoid	ChPtchEnvL	Triangle or trapezoid
Ch Rate L	0.01 to 10.00 Hz	Ch Rate R	0.01 to 10.00 Hz
Ch Depth L	0.0 to 100.0 ct	Ch Depth R	0.0 to 100.0 ct
Ch Delay L	0.0 to 720.0 ms	Ch Delay R	0.0 to 720.0 ms
Ch Fdbk L	-100 to 100%	Ch Fdbk R	-100 to 100%
Ch Xcouple	0 to 100%	Ch HF Damp	16 to 25088 Hz

Parameters (MonoPitcher+Flan):

PAGE 1

Wet/Dry	100 to 100%wet	Out Gain	Off, -79.0 to 24.0 dB
Mix Pitchr	-100 to 100%		
Mix Flange	-100 to 100%	Fl Tempo	System, 1 to 255 BPM
Pt/Dry->Fl	0 to 100%		

PAGE 3

Pt Inp Bal	-100 to 100%	Pt Out Pan	-100 to 100%
Pt Pitch	C-1 to G 9	Pt Offset	-12.0 to 12.0 ST
Pt PkSplit	0 to 100%	Pt PkShape	-1.0 to 1.0

Fl LFO cfg	Dual1Tap	Fl LRPhase	0.0 to 360.0 deg
Fl Rate 1	0 to 32 bts	Fl Rate 2	0 to 32 bts

Fl Xcurs 1	0.0 to 230.0 bts	Fl Xcurs 2	0.0 to 230.0 bts
Fl Delay 1	0.0 to 230.0 ms	Fl Delay 2	0.0 to 230.0 ms
Fl Phase 1	0.0 to 360.0 deg	Fl Phase 2	0.0 to 360.0 deg
Fl Fdbk	-100 to 100%	Fl HF Damp	16 to 25088 Hz

<u>Wet/Dry</u>	This is a simple mix of the pitched and chorused or flanged signal relative to the dry input signal.
<u>Out Gain</u>	The overall gain or amplitude at the output of the effect.
<u>Mix Pitchr</u>	The amount of the pitcher signal to be sent directly to the output as a percent. Any signal that this parameter sends to the output does not get sent to the chorus or flanger.
<u>Mix Chorus, Mix Flange</u>	The amount of the flanger or chorus signal to send to the output as a percent.
<u>Pt/Dry->Ch, Pt/Dry->Fl</u>	The relative amount of pitcher signal to dry signal to send to the chorus or flanger. At 0% the dry input signal is routed to the chorus or flanger. At 100%, the chorus or flanger receives its input entirely from the pitcher.
<u>Pt Inp Bal</u>	Since this is a mono algorithm, an input balance control is provided to mix the left and right inputs to the pitcher. -100% is left only, 0% is left plus right, and 100% is right only.
<u>Pt Out Pan</u>	Pans the mono pitcher output from left (-100%) to center (0%) to right (100%)
<u>Pt Pitch</u>	The "fundamental" frequency of the Pitcher output. This sets the frequency of the lowest peak in terms of standard note names. All the other peaks will be at multiples of this pitch.
<u>Pt PkSplit</u>	Splits the pitcher peaks into two peaks, which both move away from their original unsplit position, one going up and the other down in frequency. At 0% there is no splitting; all peaks are at multiples of the fundamental. At 100% the peak going up merges with the peak going down from the next higher position.
<u>Pt Offset</u>	An offset in semitones from the frequency specified in Pitch.
<u>Pt PkShape</u>	Controls the shape of the pitcher spectral peaks. 0.0 gives the most "pitchiness" to the output, in that the peaks are narrow, and there is not much energy between them. -1.0 makes the peaks wider. 1.0 brings up the level between the peaks.
<u>Ch PtchEnv, Ch Rate, Ch Depth, Ch Delay, Ch Fdbk, Ch Xcouple, Ch HF Damp</u>	Refer to Chorus documentation.
<u>Fl LFO cfg</u>	Sets the user interface mode for controlling each of the 4 flange LFOs.
<u>Fl LRPhase</u>	Controls the relative phase between left channel LFOs and right channel LFOs. In Dual1Tap mode, however, this parameter is accurate only when Fl Rate 1 and Fl Rate 2 are set to the same speed, and only after the Fl LFO cfg parameter is moved, or the algorithm is called up.
<u>Fl Phase 1, Fl Phase 2</u>	These adjust the corresponding LFO phase relationships between themselves and the internal beat clock.
<u>Fl Rate, Fl Depth, Fl Delay, Fl Fdbk, Fl Xcouple, Fl HF Damp</u>	Refer to Flanger documentation. Parameters with a 1 or 2 correspond to LFO taps organized as described above.

FXAlgs #724-6, 728: Distortion

- FXAlg #724 – Mono Distortion**
- FXAlg #725 – MonoDistort + Cab**
- FXAlg #726 – MonoDistort + EQ**
- FXAlg #728 – StereoDistort+EQ**

Small distortion algorithms

Allocation Units: 1 for Mono Distortion; 2 for MonoDistort + Cab; 2 for MonoDistort + EQ; 3 for StereoDistort + EQ

Mono Distortion sums its stereo input to mono, performs distortion followed by a hipass filter and sends the result as centered stereo.

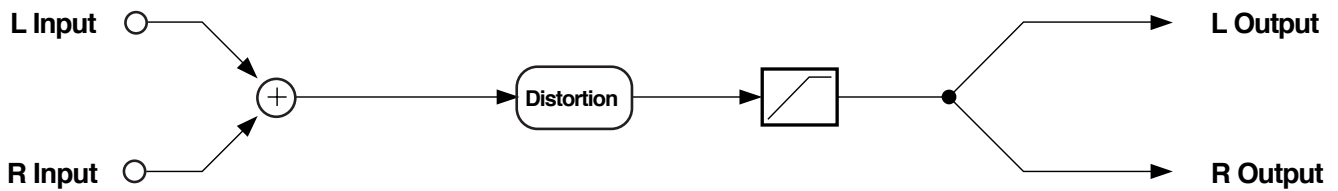

Block diagram of Mono Distortion

MonoDistort + EQ is similar to Mono Distortion except the single hipass filter is replaced with a pair of second-order hipass/lowpass filters to provide rudimentary speaker cabinet modeling. The hipass and lowpass filters are then followed by an EQ section with bass and treble shelf filters and two parametric mid filters.

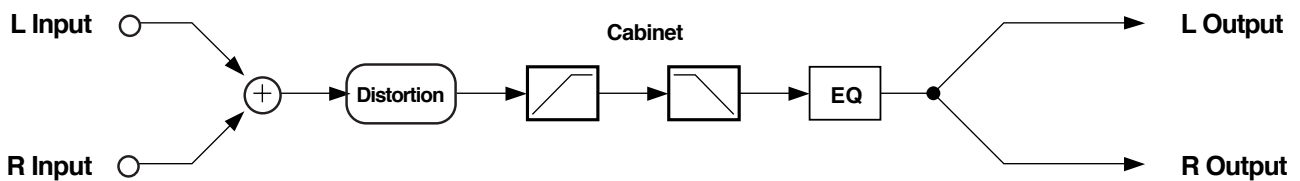

Block diagram of MonoDistort + EQ

StereoDistort + EQ processes the left and right channels separately, though there is only one set of parameters for both channels. The stereo distortion has only one parametric mid filter.

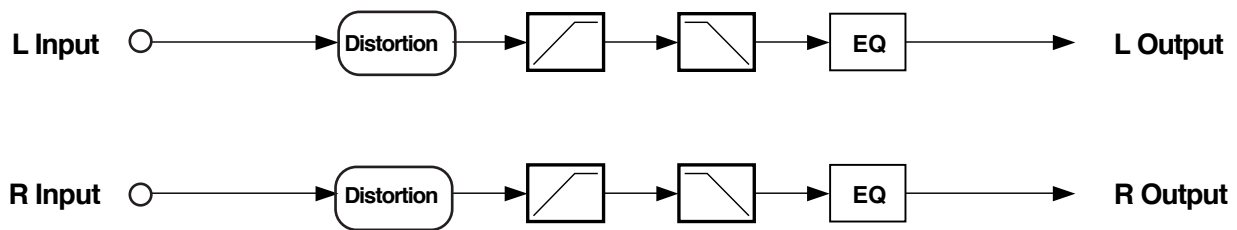

Block diagram of StereoDistort+EQ

MonoDistort + Cab is also similar to Mono Distortion except the hipass is replaced by a full speaker cabinet model. There is also a panner to route the mono signal between left and right outputs. In MonoDistort + Cab, the distortion is followed by a model of a guitar amplifier cabinet. The model can be bypassed, or there are eight presets which were derived from measurements of real cabinets. (See descriptions of FXAlgs #729-732 in this book for more information.)

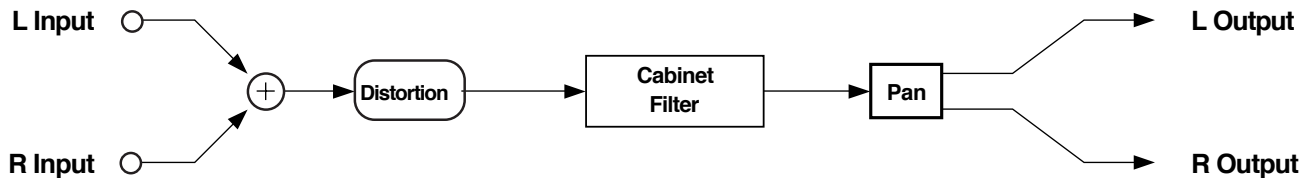

Block diagram of MonoDistort + Cab

The distortion algorithm will soft clip the input signal. The amount of soft clipping depends on how high the distortion drive parameter is set. Soft clipping means that there is a smooth transition from linear gain to saturated overdrive. Higher distortion drive settings cause the transition to become progressively sharper or “harder”. The distortion never produces hard or digital clipping, but it does approach it at high drive settings. When you increase the distortion drive parameter you are increasing the gain of the algorithm until the signal reaches saturation. You will have to compensate for increases in drive gain by reducing the output gain. These algorithms will not digitally clip unless the output gain is over-driven.

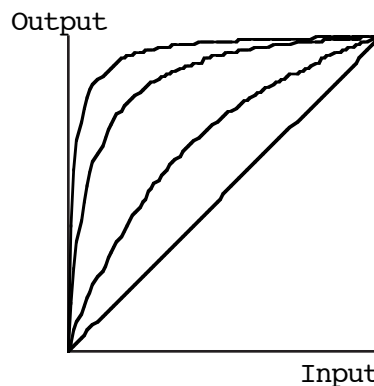

Input/Output Transfer Characteristic of Soft Clipping at Various Drive Settings

Signals which are symmetric in amplitude (they have the same shape if they are inverted, positive for negative) will usually produce odd harmonic distortion. For example, a pure sine wave will produce smaller copies of itself at 3, 5, 7, etc. times the original frequency of the sine wave. In the MonoDistort + EQ, a dc offset may be added to the signal to break the amplitude symmetry and will cause the distortion to produce even harmonics. This can add a “brassy” character to the distorted sound. The dc offset added prior to distortion gets removed at a later point in the algorithm.

Parameters - Mono Distortion:

PAGE 1

Wet/Dry	0 to 100%wet	Out Gain	Off, -79.0 to 24.0 dB
Dist Drive	0 to 96 dB		
Warmth	16 to 25088 Hz		
Highpass	16 to 25088 Hz		

MonoDistort + Cab:

PAGE 1

Wet/Dry	0 to 100%wet	Out Gain	Off, -79.0 to 24.0 dB
Dist Drive	0 to 96 dB		
Warmth	16 to 25088 Hz	Cab Bypass	In or Out
		Cab Preset	Basic

MonoDistort + EQ:

PAGE 1

Wet/Dry	0 to 100%wet	Out Gain	Off, -79.0 to 24.0 dB
Dist Drive	0 to 96 dB		
Warmth	16 to 25088 Hz	dc Offset	-100 to 100%
Cabinet HP	16 to 25088 Hz	Cabinet LP	16 to 25088 Hz

PAGE 2

Bass Gain	-79.0 to 24.0 dB	Treb Gain	-79.0 to 24.0 dB
Bass Freq	16 to 25088 Hz	Treb Freq	16 to 25088 Hz
Mid1 Gain	-79.0 to 24.0 dB	Mid2 Gain	-79.0 to 24.0 dB
Mid1 Freq	16 to 25088 Hz	Mid2 Freq	16 to 25088 Hz
Mid1 Width	0.010 to 5.000 oct	Mid2 Width	0.010 to 5.000 oct

StereoDistort+EQ:

PAGE 1

Wet/Dry	0 to 100%wet	Out Gain	Off, -79.0 to 24.0 dB
Dist Drive	0 to 96 dB		
Warmth	16 to 25088 Hz		
Cabinet HP	16 to 25088 Hz	Cabinet LP	16 to 25088 Hz

PAGE 2

Bass Gain	-79.0 to 24.0 dB	Treb Gain	-79.0 to 24.0 dB
Bass Freq	16 to 25088 Hz	Treb Freq	16 to 25088 Hz
Mid Gain	-79.0 to 24.0 dB		
Mid Freq	16 to 25088 Hz		
Mid Width	0.010 to 5.000 oct		

<u>Wet/Dry</u>	The amount of distorted (wet) signal relative to unaffected (dry) signal.
<u>Out Gain</u>	The overall gain or amplitude at the output of the effect. For distortion, it is often necessary to turn the output gain down as the distortion drive is turned up.
<u>Dist Drive</u>	Applies a boost to the input signal to overdrive the distortion algorithm. When overdriven, the distortion algorithm will soft-clip the signal. Since distortion drive will make your signal very loud, you may have to reduce the Out Gain as the drive is increased.
<u>Warmth</u>	A lowpass filter in the distortion control path. This filter may be used to reduce some of the harshness of some distortion settings without reducing the bandwidth of the signal.
<u>Cab Bypass</u>	The guitar amplifier cabinet simulation may be bypassed. When set to "In", the cabinet simulation is active; when set to "Out", there is no cabinet filtering. [MonoDistort + Cab]
<u>Cab Preset</u>	Eight preset cabinets have been created based on measurements of real guitar amplifier cabinets. The presets are Basic, Lead 12, 2x12, Open 12, Open 10, 4x12, Hot 2x12, and Hot 12. See description of FX Algs #729-732 for more information. [MonoDistort + Cab]
<u>Highpass</u>	Allows you to reduce the bass content of the distortion content. If you need more filtering to better simulate a speaker cabinet, you will have to choose a larger distortion algorithm. [Mono Distortion]

MonoDistort + EQ and StereoDistort+EQ

<u>Cabinet HP</u>	A hipass filter which controls the low-frequency limit of a simulated loudspeaker cabinet.
<u>Cabinet LP</u>	A lowpass filter which controls the high-frequency limit of a simulated cabinet.
<u>Bass Gain</u>	The amount of boost or cut that the bass shelving filter should apply to the low frequency signals in dB. Every increase of 6 dB approximately doubles the amplitude of the signal. Positive values boost the bass signal below the specified frequency. Negative values cut the bass signal below the specified frequency.
<u>Bass Freq</u>	The center frequency of the bass shelving filter in intervals of one semitone.
<u>Treb Gain</u>	The amount of boost or cut that the treble shelving filter should apply to the high frequency signals in dB. Every increase of 6 dB approximately doubles the amplitude of the signal. Positive values boost the treble signal above the specified frequency. Negative values cut the treble signal above the specified frequency.
<u>Treb Freq</u>	The center frequency of the treble shelving filter in intervals of one semitone.
<u>Mid Gain</u>	The amount of boost or cut that the mid parametric filter should apply in dB. Every increase of 6 dB approximately doubles the amplitude of the signal. Positive values boost the signal at the specified frequency. Negative values cut the signal at the specified frequency.
<u>Mid Freq</u>	The center frequency of the mid parametric filter in intervals of one semitone. The boost or cut will be at a maximum at this frequency.
<u>Mid Wid</u>	The bandwidth of the mid parametric filter may be adjusted. You specify the bandwidth in octaves. Small values result in a very narrow filter response. Large values result in a very broad response.

FXAlg #727: PolyDistort + EQ

Eight-stage distortion followed by equalization

Allocation Units: 2

PolyDistort + EQ is a distortion algorithm followed by equalization. The algorithm consists of an input gain stage, and then eight cascaded distortion stages. Each stage is followed by a one-pole LP filter. There is also a one pole LP in front of the first stage. After the distortion there is a 4-band EQ section: Bass, Treble, and two Parametric Mids. After the distortion there is a 4-band EQ section: Bass, Treble, and two Parametric Mids.

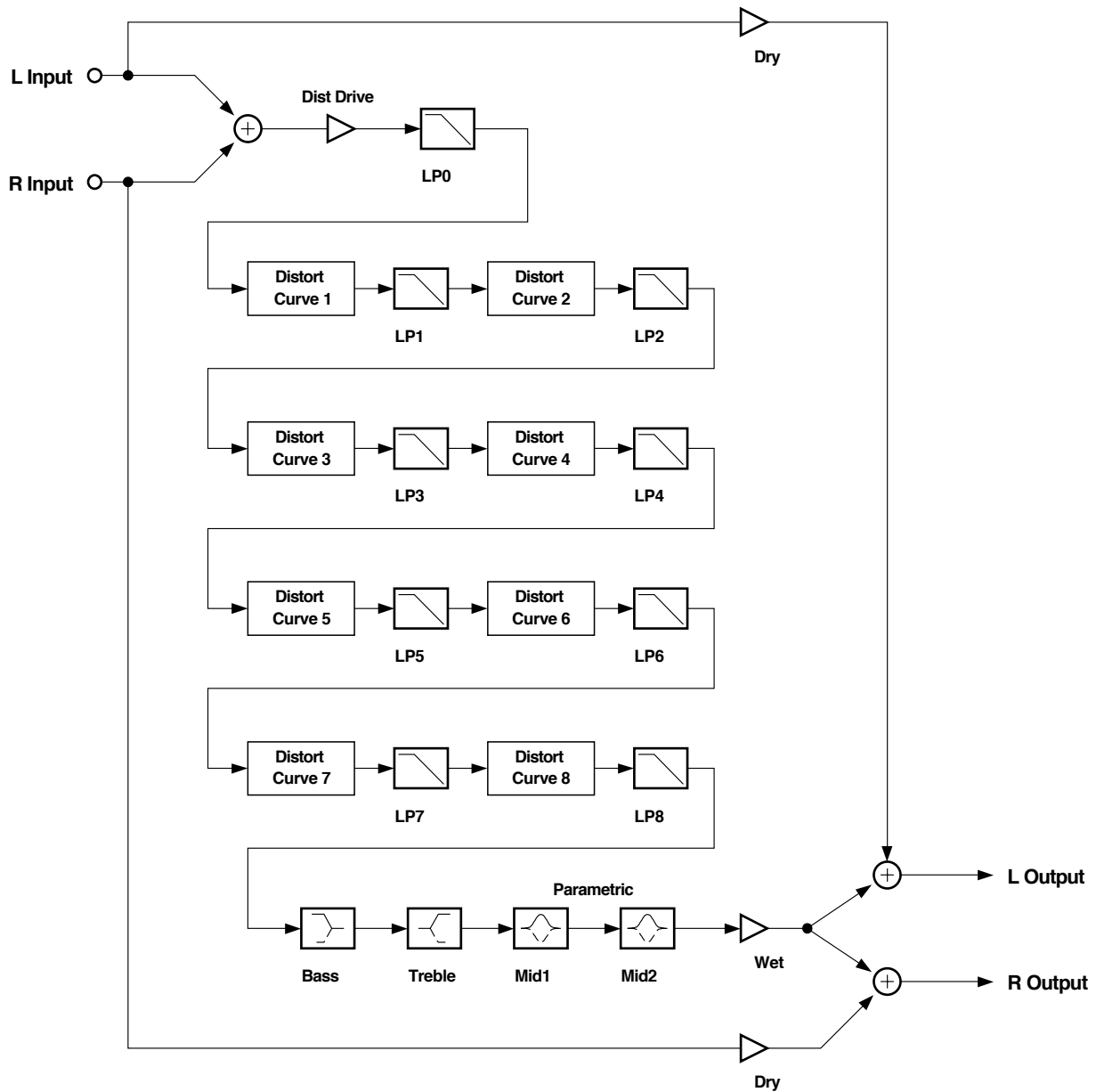

Block diagram of PolyDistort + EQ

PolyDistort is an unusual distortion algorithm which provides a great number of parameters to build a distortion sound from the ground up. The eight distortion stages each add a small amount of distortion to the sound. Taken together, they can produce a very harsh heavy metal sound. Between each distortion stage is a lopass filter. The lopass filters work with the distortion stages to help mellow out the sound. Without any lopass filters the distortion will get very harsh and raspy.

Stages of distortion can be removed by setting the Curve parameter to 0. You can then do a 6, 4, or 2 stage distortion algorithm. The corresponding lopasses should be turned off if there is no distortion in a section. More than 4 stages seem necessary for lead guitar sounds. For a cleaner sound, you may want to limit yourself to only 4 stages.

Once you have set up a distorted sound you are satisfied with, the Dist Drive parameter controls the input gain to the distortion, providing a single parameter for controlling distortion amount. You will probably find that you will have to cut back on the output gain as you drive the distortion louder.

Post-distortion EQ is definitely needed to make things sound right. This should be something like a guitar speaker cabinet simulator, although not exactly, since we are already doing a lot of lopass filtering inside the distortion itself. Possible EQ settings you can try are Treble -20 dB at 5 kHz, Bass -6 dB at 100 Hz, Mid1, wide, +6 dB at 2 kHz, Mid2, wide, +3 dB at 200 Hz, but of course you should certainly experiment to get your sound. The Treble is helping to remove raspiness, the Bass is removing the extreme low end like an open-back guitar cabinet (not that guitar speakers have that much low end anyway), Mid1 adds enough highs so that things can sound bright even in the presence of all the HF roll-off, and Mid2 adds some warmth. Your favorite settings will probably be different. Boosting the Treble may not be a good idea.

Pre-distortion EQ, available on the KDFX Studio INPUT pages, is also useful for shaping the sound. EQ done in front of the distortion will not be heard as simple EQ, because the distortion section makes an adjustment in one frequency range felt over a much wider range due to action of the distortion. Simple post-EQ is a bit too obvious for the ear, and it can get tiring after a while.

Parameters:

PAGE 1

Wet/Dry	0 to 100%wet	Out Gain	Off, -79.0 to 24.0 dB
Dist Drive	Off, -79.0 to 48.0 dB		

PAGE 2

Curve 1	0 to 127%	Curve 5	0 to 127%
Curve 2	0 to 127%	Curve 6	0 to 127%
Curve 3	0 to 127%	Curve 7	0 to 127%
Curve 4	0 to 127%	Curve 8	0 to 127%

PAGE 2

LP0 Freq	16 to 25088 Hz		
LP1 Freq	16 to 25088 Hz	LP5 Freq	16 to 25088 Hz
LP2 Freq	16 to 25088 Hz	LP6 Freq	16 to 25088 Hz
LP3 Freq	16 to 25088 Hz	LP7 Freq	16 to 25088 Hz
LP4 Freq	16 to 25088 Hz	LP8 Freq	16 to 25088 Hz

Bass Gain	-79.0 to 24.0 dB	Treb Gain	-79.0 to 24.0 dB
Bass Freq	16 to 25088 Hz	Treb Freq	16 to 25088 Hz
Mid1 Gain	-79.0 to 24.0 dB	Mid2 Gain	-79.0 to 24.0 dB
Mid1 Freq	16 to 25088 Hz	Mid2 Freq	16 to 25088 Hz
Mid1 Width	0.010 to 5.000 oct	Mid2 Width	0.010 to 5.000 oct

- Wet/Dry This is a simple mix of the distorted signal relative to the dry undistorted input signal.
- Out Gain The overall gain or amplitude at the output of the effect. For distortion, it is often necessary to turn the output gain down as the distortion drive is turned up.
- Dist Drive Applies gain to the input prior to distortion. It is the basic “distortion drive” control. Anything over 0 dB could clip. Normally clipping would be bad, but the distortion algorithm tends to smooth things out. Still, considering that for some settings of the other parameters you would have to back off the gain to -48 dB in order to get a not very distorted sound for full scale input, you should go easy on this amount.
- Curve *n* The curvature of the individual distortion stages. 0% is no curvature (no distortion at all). At 100%, the curve bends over smoothly and becomes perfectly flat right before it goes into clipping.
- LP *n* Freq These are the one-pole lopass controls. LP0 Freq handles the initial lopass prior to the first distortion stage. The other lopass controls follow their respective distortion stages. With all lopasses out of the circuit (set to the highest frequency), the sound tends to be too bright and raspy. With less distortion drive, less filtering is needed. If you turn off a distortion stage (set to 0%), you should turn of the lopass filter by setting it to the highest frequency.
- Bass Gain The amount of boost or cut that the bass-shelving filter should apply to the low-frequency signals in dB. Every increase of 6 dB approximately doubles the amplitude of the signal. Positive values boost the bass signal below the specified frequency. Negative values cut the bass signal below the specified frequency.
- Bass Freq The center frequency of the bass shelving filter in intervals of one semitone.
- Treb Gain The amount of boost or cut that the treble-shelving filter should apply to the high-frequency signals in dB. Every increase of 6 dB approximately doubles the amplitude of the signal. Positive values boost the treble signal above the specified frequency. Negative values cut the treble signal above the specified frequency.
- Treb Freq The center frequency of the treble shelving filter in intervals of one semitone.
- Mid Gain The amount of boost or cut that the mid parametric filter should apply in dB. Every increase of 6 dB approximately doubles the amplitude of the signal. Positive values boost the signal at the specified frequency. Negative values cut the signal at the specified frequency.
- Mid Freq The center frequency of the mid parametric filter in intervals of one semitone. The boost or cut will be at a maximum at this frequency.
- Mid Wid The bandwidth of the mid parametric filter may be adjusted. The bandwidth is specified in octaves. Small values result in a very narrow filter response. Large values result in a very broad response.

Tube Amp/Distortion/Delay Combinations

FXAlg #729: TubeAmp<>MD>Chor

FXAlg #730: TubeAmp<>MD>Flan

FXAlg #731: PolyAmp<>MD>Chor

FXAlg #732: PolyAmp<>MD>Flan

Mono distortion circuits in combination with moving delays, and a stereo chorus or stereo flange

Allocation Units:3 each

Each of these four algorithms offer a flexible chain of effects designed primarily for guitar processing. Each chain offers a different combination of a 3-band tone control, tube-amp distortion drive, poly-amp distortion drive, cabinet simulation, chorus, flange, and a generic moving delay. The entire algorithm is monaural with the exception of the final chorus or flange at the end of each chain, which have one input and a stereo output.

At the beginning of each chain is a 3-band tone control authentically re-creating the response in many guitar preamps based on real measurements collected by Kurzweil engineers. It is adjusted with the Bass Tone, Mid Tone, and Treb Tone controls with values ranging from 0 to 10 commonly found on many guitar amps. The flattest frequency response is obtained by setting Mid Tone to 10.0, and both Bass and Treb Tone controls to 0.0.

The tone controls are integrated with one of two types of preamp drive circuits: TubeAmp and PolyAmp. The TubeAmp faithfully models the response and smooth distortion caused by overloading a vacuum tube circuit. PolyAmp is closely related to the PolyDistort algorithm offering a brighter sound quality with more sustain. The amount of distortion is controlled by adjusting the Tube Drive or Poly Drive parameter. High frequency energy caused by distortion can be rolled off by using the Warmth parameter.

Following the distortion drive element is a cabinet simulator. The cabinet simulator models the responses of various types of mic'd guitar cabinets. The preset can be selected using the Cab Preset parameter. The following is the list of cabinet presets and their descriptions:

Basic	Flat response from 100 Hz to 4 kHz with 4th order roll-offs (24dB/oct) on each end
Lead 12	Open back hard American type with one 12" driver
2x12	Closed back classic American type with two 12" drivers
Open 12	Open back classic American type with one 12" driver
Open 10	Open back classic American type with one 10" driver
4x12	Closed back British type with four 12" drivers
Hot 2x12	Closed back hot rod type with two 12" drivers
Hot 12	Open back hot rod type with one 12" driver

Tube Amp/Distortion/Delay Combinations

The cabinet can be switched on or off with the Cab In/Out parameter. The Cab Pan parameter adjusts the final pan position of the cabinet at the output of the algorithm, but this does not affect the cabinet signal fed into the final stereo flange or chorus. If Ch Wet/Dry or Fl Wet/Dry is set to 100%, this pan control will not have any audible effect since the entire output of the cabinet is fed into the flange or chorus instead of the algorithm output.

At the end of the chain is either a chorus or a flange controlled by parameters beginning with "Ch" or "Fl" respectively. The chorus and flange have mono inputs and stereo outputs. Each is a standard KDFX single tap dual channel chorus (see FXAlg #150) or flange (see FXAlg #154) with independent controls for left and right channels found in many other 1-PAU combination algorithms. The Ch Wet/Dry or Fl Wet/Dry control determines the final output mix of the algorithm. When set at 0%, only the cabinet simulator output is fed to the output of the algorithm. At 100%, only the output of the chorus or flange is heard. Left/right balance specifically for the chorus or flange can be adjusted with the Out Bal control.

In addition, there is a generic monaural moving delay segment. Its parameters begin with the letters "MD". The moving delay is flexible enough that it can serve as a chorus, flange, or straight delay. For more detailed information, refer to the section describing the Dual MovDelay and Quad MovDelay algorithms (FXAlgs #715-716). As implemented in these four algorithms, it can be inserted either before the tone controls (PreDist), or after the distortion drive (PostDist), or bypassed altogether. This is selected with the MD Insert parameter. Also provided is the MD Wet/Dry parameter that mixes the output of the moving delay circuit with its own input to be fed into the next effect in the chain.

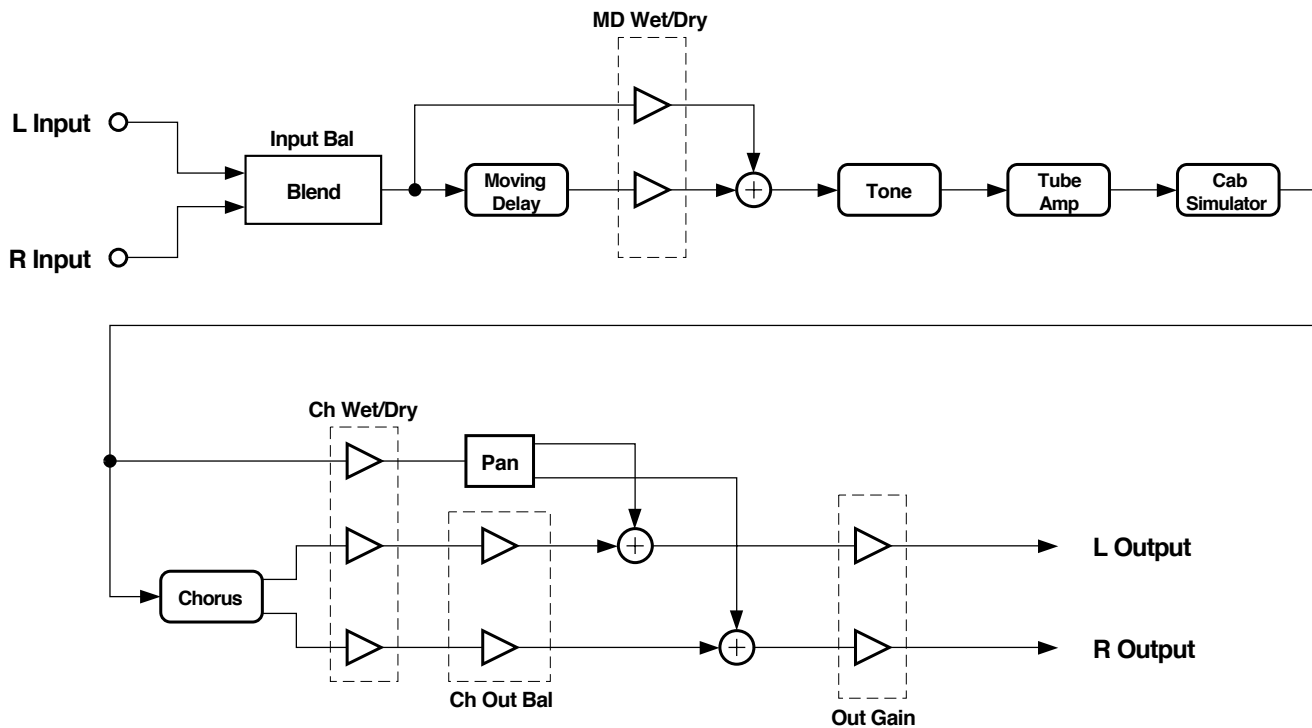

TubeAmp<>MD>Chor with moving delay inserted PreDist

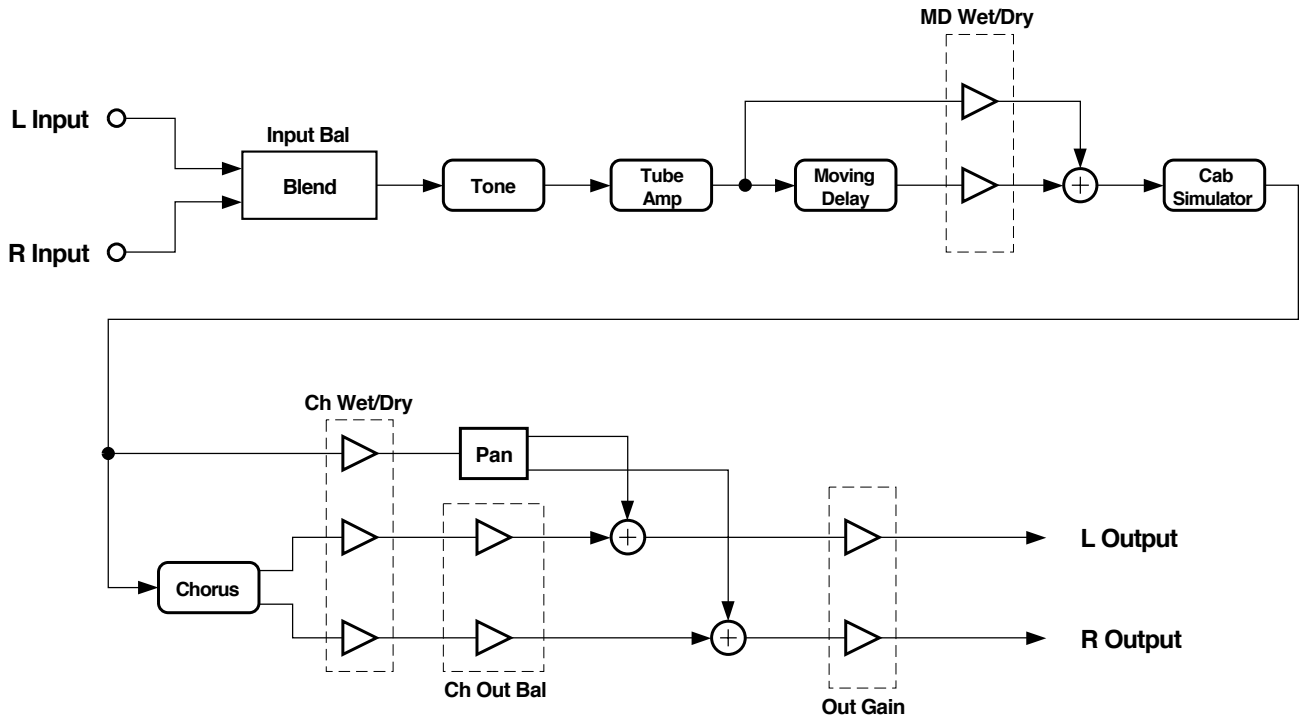

TubeAmp<>MD>Chor with moving delay inserted PostDist

Parameters:

PAGE 1

In/Out	In or Out	Out Gain	Off; -79.0 to 24.0 dB
Input Bal	-100 to 100%		

PAGE 2 (TubeAmp algs)

		Tube Drive	Off; -79.0 to 60.0 dB
		Warmth	16 to 25088 Hz
Bass Tone	0.0 to 10.0		
Mid Tone	0.0 to 10.0	Cab In/Out	In or Out
Treb Tone	0.0 to 10.0	Cab Preset	Open 12, ...
		Cab Pan	-100 to 100%

PAGE 2 (PolyAmp algs)

		Poly Drive	0.0 to 60.0 dB
		Warmth	16 to 25088 Hz
Bass Tone	0.0 to 10.0		
Mid Tone	0.0 to 10.0	Cab In/Out	In or Out
Treb Tone	0.0 to 10.0	Cab Preset	Open 12, ...
		Cab Pan	-100 to 100%

Tube Amp/Distortion/Delay Combinations

PAGE 3

MD Insert	Post Dist, ...	MD Delay	0.0 to 1000.0 ms
MD Wet/Dry	0 to 100%	MD LFOMode	Flange, ...
		MD LFORate	0.00 to 10.00 Hz
		MD LFODpth	0.0 to 200.0%
		MD Fdbk	-100 to 100%

PAGE 4 (Chorus algs)

Ch Rate L	0.01 to 10.00 Hz	Ch Rate R	0.01 to 10.00 Hz
Ch Depth L	0.0 to 100.0 cts	Ch Depth R	0.0 to 100.0 cts
Ch Delay L	0 to 720 ms	Ch Delay R	0 to 720 ms
Ch Fdbk L	-100 to 100%	Ch Fdbk R	-100 to 100%
Ch PtchEnv	Triangle or Trapezoid		
ChWet/Dry	0 to 100%	Ch Out Bal	-100 to 100%

PAGE 4 (Flange algs)

FI Rate	0 to 32 bts	FI Tempo	System; 1 to 255 BPM
FI Xcurs L	0 to 230 ms	FI Xcurs R	0 to 230 ms
FI Delay L	0 to 230 ms	FI Delay R	0 to 230 ms
FI Fdbk L	-100 to 100%	FI Fdbk R	-100 to 100%
FI Phase L	0 to 360 deg	FI Phase R	0 to 360 deg
FI Wet/Dry	0 to 100%	FI Out Bal	-100 to 100%

- In/Out Toggles the entire effect on or off. When off, the input signal is passed.
- Input Bal Adjusts the ratio of left and right algorithm inputs to be summed into the monaural signal that is processed by the effect. 0% blends equal amount of left and right. Negative values blend increasing amounts of left, while positive values blend increasing amounts of right.
- Out Gain The overall gain or amplitude at the output of the effect.
- Bass Tone, Mid Tone, Treb Tone Adjusts the 3 bands of the tone control integrated with the distortion drive circuit. Flattest response is obtained by setting Mid Tone to 10.0, and both Bass Tone and Treb Tone to 0.0.
- Tube Drive, Poly Drive Adjusts the gain into each distortion circuit. Higher values produce more distortion.
- Warmth Adjusts a 1-pole (6dB/oct) lopass filter applied after distortion.
- Cab In/Out Turns the cabinet simulator on or off.
- Cab Preset Selects the preset cabinet type.
- Cab Pan Adjusts the output pan position of the cabinet simulator signal that is mixed at the output of the algorithm. Note that when Ch Wet/Dry or FI Wet/Dry is set to 100%, no signal from the cabinet is mixed directly to the output, so this parameter has no affect.
- MD Insert Selects where in the signal chain the moving delay is to be. PreDist places it before the distortion and tone circuit. PostDist places it between the distortion circuit and cabinet simulator, and Bypass takes it completely out of the path.
- MD Wet/Dry Adjusts the ratio of the moving delay output mixed with its own input to be fed to the next effect in the chain.

<u>MD Delay</u>	Adjusts the delay time for the moving delay circuit, which is the center of LFO excursion.
<u>MD LFOMode</u>	Adjusts the LFO excursion type. In Flange mode, the LFO is optimized for flange effects and LFO Dpth adjusts the excursion amount. In ChorTri and ChorTrap modes, the LFO is optimized for triangle and trapezoidal pitch envelopes respectively, and LFO Dpth adjusts the amount of chorus detuning. In Delay mode, the LFO is turned off leaving a basic delay. LFO Rate and LFO Dpth in Delay mode are disabled.
<u>MD LFORate</u>	Adjusts the LFO speed for the moving delay circuit.
<u>MD LFODpth</u>	In Flange LFO mode, this adjusts an arbitrary LFO excursion amount. In ChorTri and ChorTrap modes, this controls the chorus detune amount. In delay mode, this is disabled.
<u>MD Fdbk</u>	Adjusts the level of the moving delay circuit output signal fed back into its own input. Negative values polarity-invert the feedback signal.
<u>Ch Wet/Dry, Fl Wet/Dry</u>	Adjusts the ratio of flange or chorus signal and the cabinet simulator signal fed to the output of the algorithm. 0% feeds only the cabinet simulator to the output bypassing the final chorus or flange. 100% feeds only the flange or chorus to the output.
<u>Ch Out Bal, Fl Out Bal</u>	Adjusts the left/ right output balance of the chorus or flange signal. Negative values balance toward the left while positive values balance toward the right.

FXAlg #733: VibChor+Rotor 2 • FXAlg #734: VibChor+Rotor 4

Vibrato/chorus, through optional distortion, into rotating speaker
Allocation Units: 2 for VibChor+Rotor 2; 4 for VibChor+Rotor 4

The VibChor+Rotor algorithms contain multiple effects designed for the Hammond B3[®] emulation (KB3 mode). These effects are the Hammond[®] vibrato/chorus, amplifier distortion, and rotating speaker (Leslie[®]). Each of these effects may be turned off or bypassed, or the entire algorithm may be bypassed.

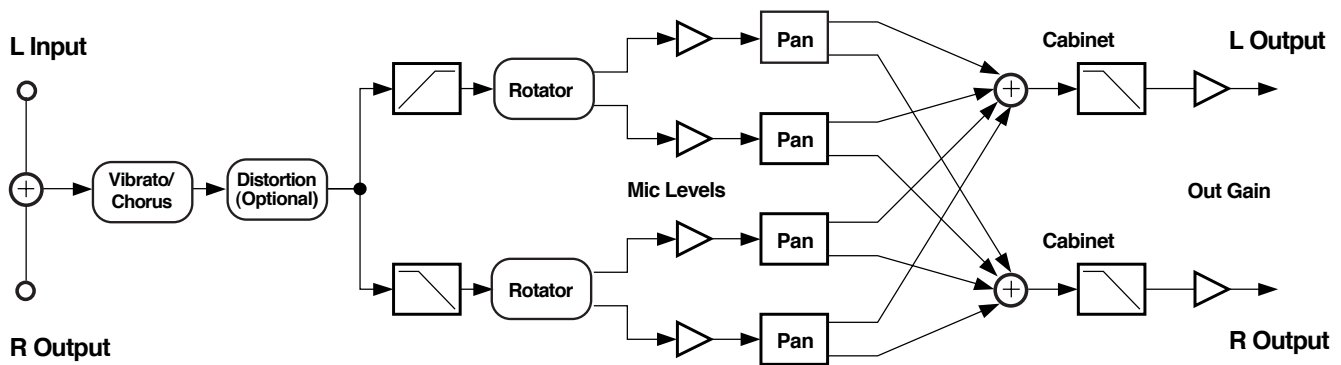

Block diagram of VibChor+Rotor

The first effect in the chain is the Hammond vibrato/chorus algorithm. The vibrato/chorus has six settings which are the same as those used in the Hammond B3: three vibrato (V1, V2, V3) and three chorus (C1, C2, C3) settings. In VibChor+Rotor 4, the vibrato chorus has been carefully modeled after the electro-mechanical vibrato/chorus in the B3. The vibrato/chorus in VibChor+Rotor 2 uses a conventional design, which has been set to match the B3 sound as closely as possible, but does not quite have the same character as the VibChor+Rotor 4 vibrato/chorus.

In VibChor+Rotor 4 an amplifier distortion algorithm follows the vibrato/chorus. See the section in this book on FXAlg #724 for more information about the distortion algorithm.

Finally, the signal passes through a rotating speaker routine. The rotating speaker has separately controllable tweeter and woofer drivers. The signal is split into high and low frequency bands and the two bands are run through separate rotors. The upper and lower rotors each have a pair of virtual microphones which can be positioned at varying positions (angles) around the rotors. An angle of 0° is loosely defined as the front. You can also control the levels and left-right panning of each virtual microphone. The signal is then passed through a final lowpass filter to simulate the band-limiting effect of the speaker cabinet.

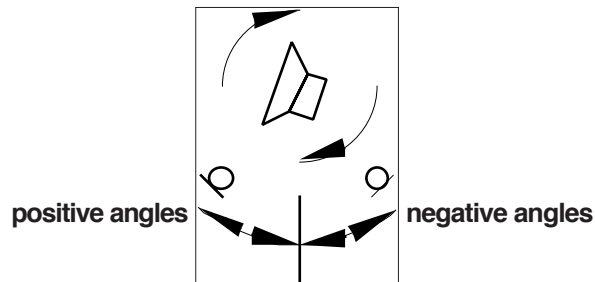

Rotating speaker with virtual microphones

For the rotating speakers, you can control the crossover frequency of the high and low frequency bands (the frequency where the high and low frequencies get separated). The rotating speakers for the high and low frequencies have their own controls. For both, the rotation rate, the effective driver size and tremolo can be set. The rotation rate sets how fast the rotating speaker is spinning. The effective driver size is the radius of the path followed by the speaker relative to its center of rotation. This parameter is used to calculate the resulting Doppler shift of the moving speaker. Doppler shift is the pitch shift that occurs when a sound source moves toward or away from you the listener. In a rotating speaker, the Doppler shift will sound like vibrato. As well as Doppler shift, there will be some acoustic shadowing as the speaker is alternately pointed away from you and toward you. The shadowing is simulated with a tremolo over which you can control the tremolo depth and “width”. The high-frequency driver (rotating horn) will have a narrower acoustic beam width (dispersion) than the low-frequency driver, and the widths of both may be adjusted. Note that it can take up to one full speaker rotation before you hear changes to tremolo when parameter values are changed. Negative microphone angles take a longer time to respond to tremolo changes than positive microphone angles.

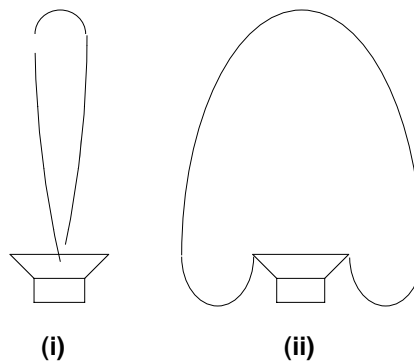

Acoustic beams for (i) low frequency driver and (ii) high frequency driver.

You can control resonant modes within the rotating speaker cabinet with the Lo and Hi Resonate parameters. For a realistic rotating speaker, the resonance level and delay excursion should be set quite low. High levels will give wild pitch shifting.

Parameters:

PAGE 1

In/Out	In or Out	Out Gain	Off, -79.0 to 24.0 dB
VibChInOut	In or Out	Dist Drive	0 to 96 dB
Vib/Chor	V1	DistWarmth	16 to 25088 Hz
Roto InOut	In or Out	Cabinet LP	16 to 25088 Hz

PAGE 2

Xover	16 to 25088 Hz		
Lo Gain	Off, -79.0 to 24.0 dB	Hi Gain	Off, -79.0 to 24.0 dB
Lo Rate	-10.00 to 10.00 Hz	Hi Rate	-10.00 to 10.00 Hz
Lo Size	0 to 250 mm	Hi Size	0 to 250 mm
Lo Trem	0 to 100%	Hi Trem	0 to 100%
Lo Beam W	45.0 to 360.0 deg	Hi Beam W	45.0 to 360.0 deg

PAGE 3

LoMicA Pos	-180.0 to 180.0 deg	LoMicB Pos	-180.0 to 180.0 deg
LoMicA Lvl	0 to 100%	LoMicB Lvl	0 to 100%
LoMicA Pan	-100 to 100%	LoMicB Pan	-100 to 100%
HiMicA Pos	-180.0 to 180.0 deg	HiMicB Pos	-180.0 to 180.0 deg
HiMicA Lvl	0 to 100%	HiMicB Lvl	0 to 100%
HiMicA Pan	-100 to 100%	HiMicB Pan	-100 to 100%

PAGE 4

LoResonate	0 to 100%	HiResonate	0 to 100%
Lo Res Dly	10 to 2550 samp	Hi Res Dly	10 to 2550 samp
LoResXcurs	0 to 510 samp	HiResXcurs	0 to 510 samp
ResH/LPhase	0.0 to 360.0 deg		

- In/Out When set to "In", the algorithm is active; when set to "Out" the algorithm is bypassed.
- Out Gain The overall gain or amplitude at the output of the effect. For distortion, it is often necessary to turn the output gain down as the distortion drive is turned up.
- VibChInOut When set to "In" the vibrato/chorus is active; when set to "Out" the vibrato/chorus is bypassed.
- Vib/Chor This control sets the Hammond B3® vibrato/chorus. There are six settings for this effect: three vibratos "V1", "V2", "V3", and three choruses "C1", "C2", "C3"
- Roto InOut When set to "In" the rotary speaker is active; when set to "Out" the rotary speaker is bypassed.
- Dist Drive Applies a boost to the input signal to overdrive the distortion algorithm. When overdriven, the distortion algorithm will soft-clip the signal. Since distortion drive will make your signal very loud, you may have to reduce the Out Gain as the drive is increased. [VibChor+Rotor 4 only]

<u>DistWarmth</u>	A lowpass filter in the distortion control path. This filter may be used to reduce some of the harshness of some distortion settings without reducing the bandwidth of the signal. [VibChor+Rotor 4 only]
<u>Cabinet LP</u>	A lowpass filter to simulate the band-limiting of a speaker cabinet. The filter controls the upper frequency limit of the output.
<u>Xover</u>	The frequency at which high and low frequency bands are split and sent to separate rotating drivers.
<u>Lo Gain</u>	The gain or amplitude of the signal passing through the rotating woofer (low-frequency driver).
<u>Lo Rate</u>	The rotation rate of the rotating woofer (low-frequency driver). The woofer can rotate clockwise or counter-clockwise. The direction of rotation depends on the sign of the rate parameter. Assuming microphone angles are set toward the front (between -90° and 90°) and microphones at positive angles are panned to the right (positive pan values), then positive rates correspond to clockwise rotation when viewed from the top.
<u>Lo Size</u>	The effective size (radius of rotation) of the rotating woofer in millimeters. Affects the amount of Doppler shift or vibrato of the low frequency signal.
<u>Lo Trem</u>	Controls the depth of tremolo of the low frequency signal. Expressed as a percentage of full scale tremolo.
<u>Lo Beam W</u>	The rotating speaker effect attempts to model a rotating woofer for the low frequency driver. The acoustic radiation pattern of a woofer tends to range from omnidirectional (radiates in directions in equal amounts) to a wide beam. You may adjust the beam width from 45° to 360°. If you imagine looking down on the rotating speaker, the beam angle is the angle between the -6 dB levels of the beam. At 360°, the woofer is omnidirectional.
<u>Hi Gain</u>	The gain or amplitude of the signal passing through the rotating tweeter (high-frequency driver).
<u>Hi Rate</u>	The rotation rate of the rotating tweeter (high-frequency driver). The tweeter can rotate clockwise or counter-clockwise. The direction of rotation depends on the sign of the rate parameter. Assuming microphone angles are set toward the front (between -90° and 90°) and microphones at positive angles are panned to the right (positive pan values), then positive rates correspond to clockwise rotation when viewed from the top.
<u>Hi Size</u>	The effective size (radius of rotation) of the rotating tweeter in millimeters. Affects the amount of Doppler shift or vibrato of the high frequency signal.
<u>Hi Trem</u>	Controls the depth of tremolo of the high frequency signal. Expressed as a percentage of full scale tremolo.
<u>Hi Beam W</u>	The rotating speaker effect attempts to model a rotating horn for the high frequency driver. The acoustic radiation pattern of a horn tends to be a narrow beam. You may adjust the beam width from 45° to 360°. If you imagine looking down on the rotating speaker, the beam angle is the angle between the -6 dB levels of the beam. At 360°, the horn is omnidirectional (radiates in all directions equally).
<u>Mic Pos</u>	The angle of the virtual microphones in degrees from the “front” of the rotating speaker. This parameter is not well suited to modulation because adjustments to it will result in large sample skips (audible as clicks when signal is passing through the effect). There are four of these parameters to include 2 pairs (A and B) for high and low frequency drivers.
<u>Mic Lvl</u>	The level of the virtual microphone signal being sent to the output. There are four of these parameters to include 2 pairs (A and B) for high and low frequency drivers.
<u>Mic Pan</u>	Left-right panning of the virtual microphone signals. A setting of -100% is panned fully left, and 100% is panned fully right. There are four of these parameters to include two pairs (A and B) for high and low frequency drivers.

<u>LoResonate</u>	A simulation of cabinet resonant modes expressed as a percentage. For realism, you should use very low settings. This is for the low frequency signal path.
<u>Lo Res Dly</u>	The number of samples of delay in the resonator circuit in addition to the rotation excursion delay. This is for the low frequency signal path.
<u>LoResXcurs</u>	The number of samples of delay to sweep through the resonator at the rotation rate of the rotating speaker. This is for the low frequency signal path.
<u>HiResonate</u>	A simulation of cabinet resonant modes expressed as a percentage. For realism, you should use very low settings. This is for the high frequency signal path.
<u>Hi Res Dly</u>	The number of samples of delay in the resonator circuit in addition to the rotation excursion delay. This is for the high frequency signal path.
<u>HiResXcurs</u>	The number of samples of delay to sweep through the resonator at the rotation rate of the rotating speaker. This is for the high frequency signal path.
<u>ResH/LPhs</u>	This parameter sets the relative phases of the high and low resonators. The angle value in degrees is somewhat arbitrary and you can expect the effect of this parameter to be rather subtle.

FXAlg #734: Distort + Rotary

Small distortion followed by rotary speaker effect

Allocation Units: 2

Distort + Rotary models an amplifier distortion followed by a rotating speaker. The rotating speaker has separately controllable tweeter and woofer drivers. The algorithm has three main sections. First, the input stereo signal is summed to mono and may be distorted by a tube amplifier simulation. The signal is then passed into the rotator section where it is split into high and low frequency bands and the two bands are run through separate rotators. The two bands are recombined and measured at two positions, spaced by a controllable relative angle (microphone simulation) to obtain a stereo signal again. Finally the signal is passed through a speaker cabinet simulation.

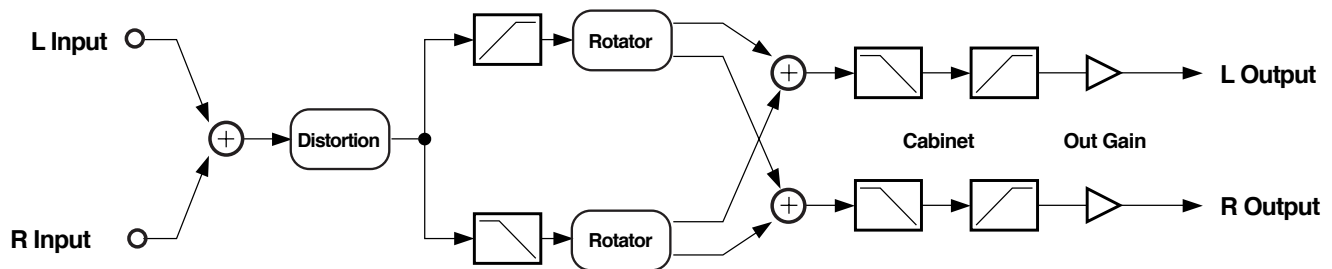

Block diagram of Distort + Rotary

The first part of Distort + Rotary is a distortion algorithm. See the section of this book on FXAlg #723 for details.

Next the signal passes through a rotating speaker routine. See the section of this book on FXAlg #733 for details.

Parameters:

PAGE 1

In/Out	In or Out	Out Gain	Off, -79.0 to 24.0 dB
Cabinet HP	16 to 25088 Hz	Dist Drive	0 to 96 dB
Cabinet LP	16 to 25088 Hz	DistWarmth	16 to 25088 Hz

PAGE 2

Xover	16 to 25088 Hz	Mic Angle	0.0 to 360.0 deg
Lo Gain	Off, -79.0 to 24.0 dB	Hi Gain	Off, -79.0 to 24.0 dB
Lo Rate	-10.00 to 10.00 Hz	Hi Rate	-10.00 to 10.00 Hz
Lo Size	0 to 250 mm	Hi Size	0 to 250 mm
Lo Trem	0 to 100%	Hi Trem	0 to 100%

PAGE 3

		ResH/LPhs	0.0 to 360.0 deg
LoResonate	0 to 100%	HiResonate	0 to 100%
Lo Res Dly	10 to 2550 samp	Hi Res Dly	10 to 2550 samp
LoResXcurs	0 to 510 samp	HiResXcurs	0 to 510 samp

FXAlg #734: Distort + Rotary

<u>In/Out</u>	When set to “In”, the algorithm is active; when set to “Off” the algorithm is bypassed.
<u>Out Gain</u>	The overall gain or amplitude at the output of the effect. For distortion, it is often necessary to turn the output gain down as the distortion drive is turned up.
<u>Dist Drive</u>	Applies a boost to the input signal to overdrive the distortion algorithm. When overdriven, the distortion algorithm will soft-clip the signal. Since distortion drive will make your signal very loud, you may have to reduce the Out Gain as the drive is increased.
<u>DistWarmth</u>	A lowpass filter in the distortion control path. This filter may be used to reduce some of the harshness of some distortion settings without reducing the bandwidth of the signal.
<u>Cabinet HP</u>	A hipass filter to simulate the band-limiting of a speaker cabinet. The filter controls the lower frequency limit of the output.
<u>Cabinet LP</u>	A lowpass filter to simulate the band-limiting of a speaker cabinet. The filter controls the upper frequency limit of the output.
<u>Xover</u>	The frequency at which high and low frequency bands are split and sent to separate rotating drivers.

For details on the rest of the parameters see the previous section (FXAlg #733) of this book.

FXAlg #735/6: KB3 FX

Vibrato/chorus into distortion into rotating speaker into cabinet

Allocation Units: 7 for full working effect (4 for KB3 FXBus, 3 for KB3 AuxFX)

The KB3 FXBus and KB3 AuxFX algorithms contain multiple effects designed for the Hammond B3 emulation (KB3 mode). For correct operation, both effects must be running at the same time, with the output of KB3 FXBus feeding the input of KB3 AuxFX. The two algorithms work as one algorithm which use all the available KDFX resources. While the input to KB3 FXBus is stereo (which gets summed to mono) and the output from KB3 AuxFX is stereo, the signals between the two algorithms are the low frequency (left) and high frequency (right) signal bands used to drive the lower and upper rotary speakers. It is possible to run these two algorithms as independent effects, but it is recommended.

These effects are the Hammond vibrato/chorus, amplifier distortion, and rotating speaker (Leslie) emulations. Each of these effects may be turned off or bypassed, or the entire algorithm may be bypassed. To bypass the rotary, the switches in both KB3 FXBus and KB3 AuxFX must be set to "Out".

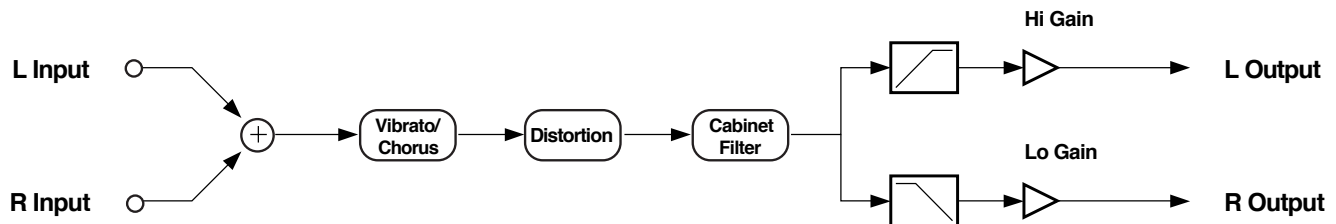

Block diagram of KB3 FXBus

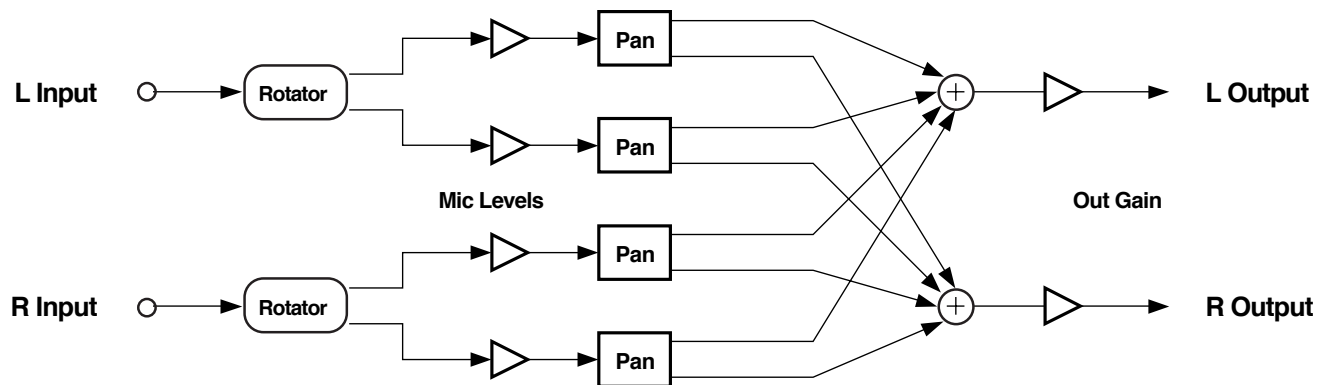

Block diagram of KB3 AuxFX

The first effect in the chain is the Hammond vibrato/chorus algorithm. The vibrato/chorus has six settings which are the same as those used in the Hammond B3: three vibrato (V1, V2, V3) and three chorus (C1, C2, C3) settings. The vibrato chorus has been carefully modeled after the electro-mechanical vibrato/chorus in the B3.

An amplifier distortion algorithm follows the vibrato/chorus. For details, see the section in this book on FXAlg #723.

The distorted signal is next passed to a cabinet emulation filter and a pair of crossover filters for band splitting. The measurements of a real Leslie® speaker was used in the design of these filters. Default parameter values reflect these measurements, but you may alter them if you like. The Lo HP parameter controls a hipass filter which defines the lowest frequency to pass through the speaker. Likewise the Hi LP parameter is a lowpass filter controlling the

FXAlg #735/6: KB3 FX

highest frequency. The crossover filters for the lower and upper drivers may be set independently. A small amount of overlap seems to work well. The gains of the high and low band signals may also be separately controlled.

At this point KB3 FXBus has finished its processing and passes the high and low signals to the KB3 AuxFX algorithm which contains the rotating-speaker routine. See the section in this book on FXAlg #733 for details.

Parameters (KB3 FXBus):**PAGE 1**

In/Out	In or Out	Out Gain	Off, -79.0 to 24.0 dB
VibChInOut	In or Out	Dist Drive	0 to 96 dB
Vib/Chor	V1	DistWarmth	16 to 25088 Hz

PAGE 2

RotoInOut	In or Out		
Lo Gain	Off, -79.0 to 24.0 dB	Hi Gain	Off, -79.0 to 24.0 dB
Lo Xover	16 to 25088 Hz	Hi Xover	16 to 25088 Hz
Lo HP	16 to 25088 Hz	Hi LP	16 to 25088 Hz

- In/Out When set to "In", the algorithm is active; when set to "Out" the algorithm is bypassed. For the entire algorithm to be active, KB3 AuxFX must also be active.
- Out Gain The overall gain or amplitude at the output of the effect. For distortion, it is often necessary to turn the output gain down as the distortion drive is turned up.
- VibChInOut When set to "In" the vibrato/chorus is active; when set to "Out" the vibrato/chorus is bypassed.
- Vib/Chor This control sets the Hammond B3® vibrato/chorus. There are six settings for this effect: three vibratos "V1", "V2", "V3", and three choruses "C1", "C2", "C3"
- Roto InOut When set to "In" the rotary speaker is active; when set to "Out" the rotary speaker is bypassed. By bypassing the rotary effect in KB3 FXBus, only the crossover filters are bypassed. You must also bypass KB3 AuxFX to completely bypass the rotary speakers. Likewise, for the entire rotary to be active, KB3 AuxFX must also be active.
- Dist Drive Applies a boost to the input signal to overdrive the distortion algorithm. When overdriven, the distortion algorithm will soft-clip the signal. Since distortion drive will make your signal very loud, you may have to reduce the Out Gain as the drive is increased.
- Warmth A lowpass filter in the distortion control path. This filter may be used to reduce some of the harshness of some distortion settings without reducing the bandwidth of the signal.
- Lo Gain The gain or amplitude of the signal passing through the rotating woofer (low frequency driver). The control is also available in KB3 AuxFX.
- Lo Xover The crossover frequency for the low frequency driver. Lo Xover controls a lowpass filter.
- Lo HP A hipass filter to simulate the band-limiting of a speaker cabinet. The filter controls the lower frequency limit of the output.
- Hi Gain The gain or amplitude of the signal passing through the rotating tweeter (high frequency driver). The control is also available in KB3 AuxFX.
- Hi Xover The crossover frequency for the high frequency driver. Hi Xover controls a hipass filter.
- Hi LP A lowpass filter to simulate the band-limiting of a speaker cabinet. The filter controls the upper frequency limit of the output.

Parameters (KB3 AuxFX):**PAGE 1**

In/Out	In or Out	Out Gain	Off, -79.0 to 24.0 dB
---------------	------------------	-----------------	------------------------------

PAGE 2

Lo Gain	Off, -79.0 to 24.0 dB	Hi Gain	Off, -79.0 to 24.0 dB
Lo Rate	-10.00 to 10.00 Hz	Hi Rate	-10.00 to 10.00 Hz
Lo Size	0 to 250 mm	Hi Size	0 to 250 mm
Lo Trem	0 to 100%	Hi Trem	0 to 100%
Lo Beam W	45.0 to 360.0 deg	Hi Beam W	45.0 to 360.0 deg

PAGE 3

LoMicA Pos	-180.0 to 180.0 deg	LoMicB Pos	-180.0 to 180.0 deg
LoMicA Lvl	0 to 100%	LoMicB Lvl	0 to 100%
LoMicA Pan	-100 to 100%	LoMicB Pan	-100 to 100%
HiMicA Pos	-180.0 to 180.0 deg	HiMicB Pos	-180.0 to 180.0 deg
HiMicA Lvl	0 to 100%	HiMicB Lvl	0 to 100%
HiMicA Pan	-100 to 100%	HiMicB Pan	-100 to 100%

PAGE 4

LoResonate	0 to 100%	HiResonate	0 to 100%
Lo Res Dly	10 to 2550 samp	Hi Res Dly	10 to 2550 samp
LoResXcurs	0 to 510 samp	HiResXcurs	0 to 510 samp
ResH/LPhs	0.0 to 360.0 deg		

In/Out When set to "In", the algorithm is active; when set to "Off" the algorithm is bypassed. For the entire algorithm to be active, KB3 FXBus must also be active with its Roto InOut parameter set to "In". To completely bypass the rotary, one or both of the In/Out or Roto InOut parameters in KB3 FXBus must also be bypassed.

Out Gain The overall gain or amplitude at the output of the effect.

Lo Gain The gain or amplitude of the signal passing through the rotating woofer (low frequency driver). The control is also available in KB3 FXBus.

Hi Gain The gain or amplitude of the signal passing through the rotating tweeter (high frequency driver). The control is also available in KB3 FXBus.

For details on the rest of the parameters see the section of this book on FXAlg #733.

FXAlg #900: Env Follow Filt

Envelope-following stereo 2-pole resonant filter

Allocation Units: 2

The envelope-following filter is a stereo resonant filter with the resonant frequency controlled by the envelope of the input signal (the maximum of left or right). The filter type is selectable and may be one of low pass (i), highpass (ii), band pass (iii), or notch (iv).

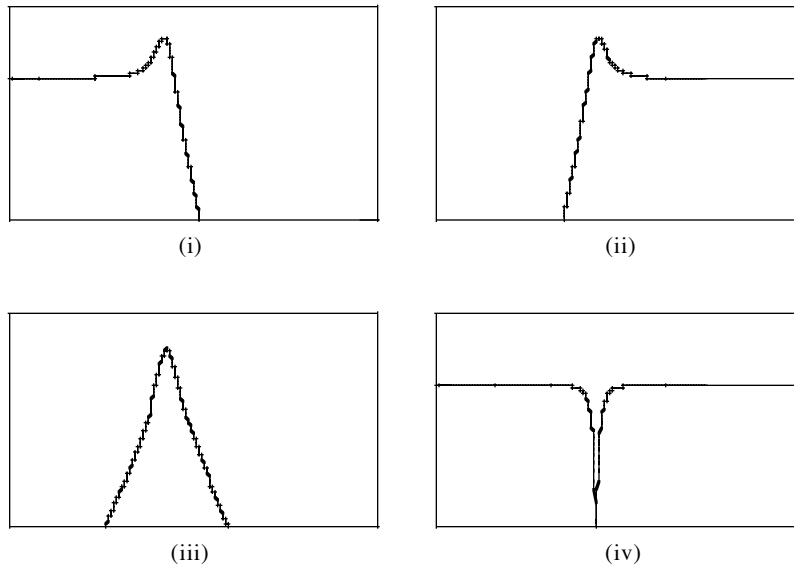

Resonant Filter Types: (i) lowpass, (ii) highpass, (iii) bandpass, and (iv) notch.

The resonant frequency of the filter will remain at the minimum frequency (Min Freq) as long as the signal envelope is below the Threshold. The Freq Sweep parameter controls how much the frequency will change with changes in envelope amplitude. The frequency range is 0 to 8372 Hz, though the minimum setting for Min Freq is 16 Hz. Note that the term minimum frequency is a reference to the resonant frequency at the minimum envelope level; with a negative Freq Sweep, the filter frequency will sweep below the Min Freq. A meter is provided to show the current resonance frequency of the filter.

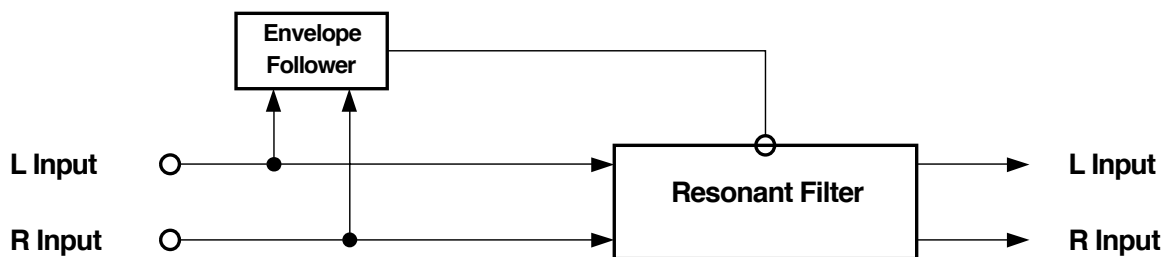

Block diagram of envelope-following filter

The filter Resonance level may be adjusted. The resonance is expressed in decibels (dB) of gain at the resonant frequency. Since 50 dB of gain is available, you will have to be careful with your gain stages to avoid clipping.

The attack and release rates of the envelope follower are adjustable. The rates are expressed in decibels per second (dB/s). The envelope may be smoothed by a lopass filter which can extend the attack and release times of the envelope follower. A level meter with a threshold marker is provided.

Parameters:

PAGE 1

Wet/Dry	0 to 100%wet	Out Gain	Off, -79.0 to 24.0 dB
FilterType	Lowpass	Min Freq	16 to 8372 Hz
F		Freq Sweep	-100 to 100%
0Hz	2k	4k	6k
		Resonance	0 to 50 dB

PAGE 2

Threshold	-79.0 to 0.0 dB	Atk Rate	0.0 to 300.0 dB/s
		Rel Rate	0.0 to 300.0 dB/s
		Smth Rate	0.0 to 300.0 dB/s
E			
-dB 60 40 * 16 * 8 4 0			

<u>Wet/Dry</u>	The amount of modulated (wet) signal relative to unaffected (dry) signal as a percent.
<u>Out Gain</u>	The overall gain or amplitude at the output of the effect.
<u>FilterType</u>	The type of resonant filter to be used. May be one of "Lowpass", "Highpass", "Bandpass", or "Notch".
<u>Min Freq</u>	The base frequency of the resonant filter. The filter resonant frequency is set to the Min Freq while the signal envelope is at its minimum level or below the threshold.
<u>Freq Sweep</u>	How far the filter frequency can change from the Min Freq setting as the envelope amplitude changes. Freq Sweep may be positive or negative so the filter frequency can rise above or fall below the Min Freq setting.
<u>Resonance</u>	The resonance level of the resonant filter. Resonance sets the level of the resonant peak. In the notch filter, this sets the amount of cut, so 0 dB provides the highest, widest notch, and higher levels make the notch increasingly narrower and shallower.
<u>Threshold</u>	Represents the level above which signal envelope must rise before the filter begins to follow the envelope. Below the threshold, the filter resonant frequency will remain at the Min frequency.
<u>Atk Rate</u>	Adjusts the upward slew rate of the envelope detector.
<u>Rel Rate</u>	Adjusts the downward slew rate of the envelope detector.
<u>Smth Rate</u>	Smooths the output of the envelope follower. Smoothing slows down the envelope follower and can dominate the attack and release rates if set to a lower rate than either of these parameters.

FXAlg #901: TrigEnvelopeFilt

Triggered envelope-following stereo 2-pole resonant filter

Allocation Units: 2

The triggered envelope-following filter is used to produce a filter sweep when the input rises above a trigger level. The triggered envelope-following filter is a stereo resonant filter with the resonant frequency controlled by a triggered envelope follower. The filter type is selectable and may be one of low pass (i), high pass (ii), band pass (iii), or notch (iv). See the previous section of this book, FXAlg #900, for diagrams of the filter actions.

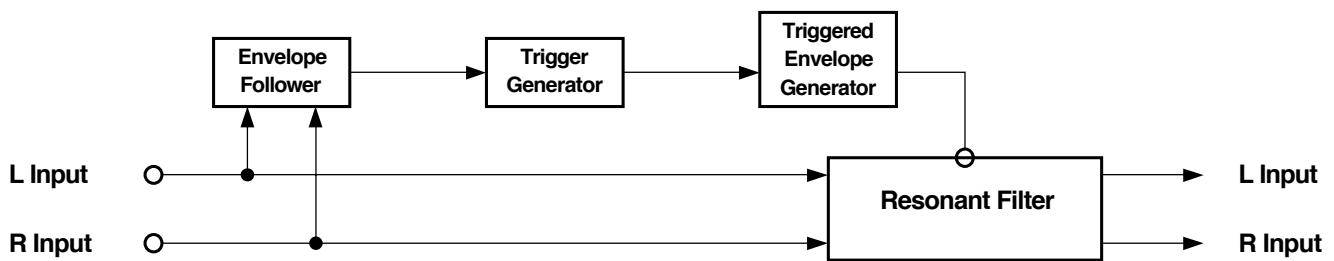

Block diagram of Triggered Envelope Filter

The resonant frequency of the filter will remain at the minimum frequency (Min Freq) prior to being triggered. On a trigger, the resonant frequency will sweep to the maximum frequency (Max Freq). The minimum and maximum frequencies may be set to any combination of frequencies between 16 and 8372 Hz. Note that the terms minimum and maximum frequency are a reference to the resonant frequencies at the minimum and maximum envelope levels; you may set either of the frequencies to be larger than the other. A meter is provided to show the current resonance frequency of the filter.

The filter Resonance level may be adjusted. The resonance is expressed in decibels (dB) of gain at the resonant frequency. Since 50 dB of gain is available, you will have to be careful with your gain stages to avoid clipping.

When the input signal envelope rises above the trigger level, an envelope generator is started which has an instant attack and exponential decay. The generated attack may be lengthened with the smoothing parameter. The smoothing parameter can also lengthen the generated decay if the smoothing rate is lower than the decay. The generated envelope is then used to control the resonant frequency of the filter.

The time constant of the envelope follower may be set (Env Rate) as well as the decay rate of the generated envelope (Rel Rate). After the detected envelope rises above the Trigger level, a trigger event cannot occur again until the signal drops below the Retrigger level. In general, Retrigger should be set lower than the Trigger level. A level meter with a trigger marker is provided.

Parameters:

PAGE 1

Wet/Dry	0 to 100%wet	Out Gain	Off, -79.0 to 24.0 dB
FilterType	Lowpass	Min Freq	16 to 8372 Hz
F		Max Freq	16 to 8372 Hz
0Hz	2k	4k	6k
		Resonance	0 to 50 dB

PAGE 2

Trigger	-79.0 to 0.0 dB	Env Rate	0.0 to 300.0 dB/s
Retrigger	-79.0 to 0.0 dB	Rel Rate	0.0 to 300.0 dB/s
		Smth Rate	0.0 to 300.0 dB/s
E			
-dB 60 40 * 16 * 8 4 0			

<u>Wet/Dry</u>	The amount of modulated (wet) signal relative to unaffected (dry) signal as a percent.
<u>Out Gain</u>	The overall gain or amplitude at the output of the effect.
<u>FilterType</u>	The type of resonant filter to be used. May be one of "Lowpass", "Highpass", "Bandpass", or "Notch".
<u>Min Freq</u>	The base frequency of the resonant filter. The filter resonant frequency is set to the base frequency while the signal envelope is below the threshold.
<u>Max Freq</u>	The frequency of the resonant filter that can be reached when the envelope follower output reaches full-scale. The resonant frequency will sweep with the envelope from the base frequency, approaching the limit frequency with rising amplitudes.
<u>Resonance</u>	The resonance level of the resonant filter. Resonance sets the level of the resonant peak. In the notch filter, this sets the amount of cut, so 0 dB provides the highest, widest notch, and higher levels make the notch increasingly narrower and shallower.
<u>Trigger</u>	The threshold at which the envelope detector triggers in fractions of full scale where 0dB is full scale.
<u>Retrigger</u>	The threshold at which the envelope detector resets such that it can trigger again in fractions of full scale where 0dB is full scale. This value is only useful when it is below the value of <u>Trigger</u> .
<u>Env Rate</u>	The envelope detector decay rate which can be used to prevent false triggering. When the signal envelope falls below the retrigger level, the filter can be triggered again when the signal rises above the trigger level. Since the input signal can fluctuate rapidly, it is necessary to adjust the rate at which the signal envelope can fall to the retrigger level. The rate is provided in decibels per second (dB/s).
<u>Rel Rate</u>	The downward slew rate of the triggered envelope generator. The rate is provided in decibels per second (dB/s).
<u>Smth Rate</u>	Smooths the output of the envelope generator. Smoothing slows down the envelope follower and can dominate the release rate if set lower rate than this parameter. You can use the smoothing rate to lengthen the attack of the generated envelope which would otherwise have an instant attack. The rate is provided in decibels per second (dB/s)

FXAlg #902: LFO Sweep Filter

LFO-following stereo 2-pole resonant filter

Allocation Units: 2

The LFO following filter is a stereo resonant filter with the resonant frequency controlled by an LFO (low-frequency oscillator). The filter type is selectable and may be one of low pass (i), high pass (ii), band pass (iii), or notch (iv). See the section of this book on FXAlg #900 for diagrams of the filter actions.

The resonant frequency of the filter will sweep between the minimum frequency (Min Freq) and the maximum frequency (Max Freq). The minimum and maximum frequencies may be set to any combination of frequencies between 16 and 8372 Hz. Note that the terms minimum and maximum frequency are a reference to the resonant frequencies at the minimum and maximum envelope levels; you may set either of the frequencies to be larger than the other, though doing so will just invert the direction of the LFO. Meters are provided to show the current resonance frequencies of the left and right channel filters.

The filter Resonance level may be adjusted. The resonance is expressed in decibels (dB) of gain at the resonant frequency. Since 50 dB of gain is available, you will have to be careful with your gain stages to avoid clipping.

You can set the frequency of the LFO using the LFO Tempo and LFO Period controls. You can explicitly set the tempo or use the system tempo from the sequencer (or MIDI clock). The LFO Period control sets the period of the LFO (the time for one complete oscillation) in terms of the number of tempo beats per LFO period.

The LFO may be configured to one of a variety of wave shapes. Available shapes are Sine, Saw+, Saw-, Pulse and Tri. Sine is simply a sinusoid waveform. Tri produces a triangular waveform, and Pulse produces a series of square pulses where the pulse width can be adjusted with the "LFO PlsWid" parameter. When pulse width is 50%, the signal is a square wave. The "LFO PlsWid" parameter is only active when the Pulse waveform is selected. Saw+ and Saw- produce rising and falling sawtooth waveforms. The Pulse and Saw waveforms have abrupt, discontinuous changes in amplitude which can be smoothed. The pulse wave is implemented as a hard clipped sine wave, and, at 50% width, it turns into a sine wave when set to 100% smoothing. The sudden change in amplitude of the sawtooths develops a more gradual slope with smoothing, ending up as triangle waves when set to 100% smoothing.

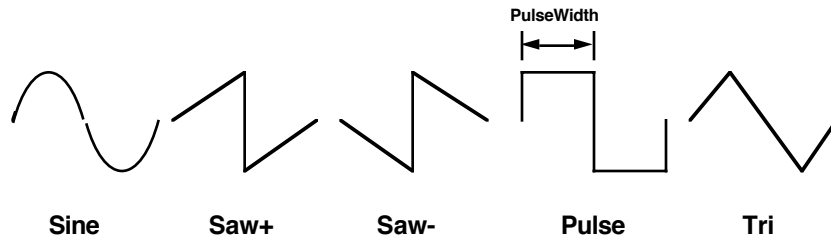

Configurable Wave Shapes

Parameters:

PAGE 1

Wet/Dry	0 to 100%wet	Out Gain	Off, -79.0 to 24.0 dB
LFO Tempo	System, 1 to 255 BPM	LFO Shape	Sine
LFO Period	1/24 to 32 bts	LFO PlsWid	0 to 100%
		LFO Smooth	0 to 100%

PAGE 2

FilterType	Lowpass	Min Freq	16 to 8372 Hz
		Max Freq	16 to 8372 Hz
		Resonance	0 to 50 dB
L Phase	0.0 to 360.0 deg	R Phase	0.0 to 360.0 deg
L		R	
0Hz	2k	4k	6k
0Hz	2k	4k	6k

<u>Wet/Dry</u>	The amount of modulated (wet) signal relative to unaffected (dry) signal as a percent.
<u>Out Gain</u>	The overall gain or amplitude at the output of the effect.
<u>LFO Tempo</u>	Basis for the rates of the LFO, as referenced to a musical tempo in bpm (beats per minute). When this parameter is set to "System", the tempo is locked to the internal sequencer tempo or to incoming MIDI clocks. When it is set to "System", sources (FUNs, LFOs, ASRs etc.) will have no effect on the Tempo parameter.
<u>LFO Period</u>	Sets the LFO rate based on the Tempo determined above: the number of beats corresponding to one period of the LFO cycle. For example, if the LFO Period is set to "4", the LFOs will take four beats to pass through one oscillation, so the LFO rate will be 1/4th of the Tempo setting. If it is set to "6/24" (=1/4), the LFO will oscillate four times as fast as the Tempo. At "0", the LFOs stop oscillating and their phase is undetermined (wherever they stopped).
<u>LFO Shape</u>	The waveform type for the LFO. Choices are Sine, Saw+, Saw-, Pulse, and Tri.
<u>LFO PlsWid</u>	When the LFO Shape is set to Pulse, the PlsWid parameter sets the pulse width as a percentage of the waveform period. The pulse is a square wave when the width is set to 50%. This parameter is active only when the Pulse waveform is selected.
<u>LFO Smooth</u>	Smooths the Saw+, Saw-, and Pulse waveforms. For the sawtooth waves, smoothing makes the waveform more like a triangle wave. For the Pulse wave, smoothing makes the waveform more like a sine wave.
<u>FilterType</u>	The type of resonant filter to be used. May be one of "Lowpass", "Highpass", "Bandpass", or "Notch".
<u>Min Freq</u>	The minimum frequency of the resonant filter. This is the resonant frequency at one of the extremes of the LFO sweep. The resonant filter frequency will sweep between the Min Freq and Max Freq.
<u>Max Freq</u>	The maximum frequency of the resonant filter. This is resonant frequency at the other extreme of the LFO sweep. The resonant filter frequency will sweep between the Min Freq and Max Freq.
<u>Resonance</u>	The resonance level of the resonant filter. Resonance sets the level of the resonant peak. In the notch filter, this sets the amount of cut, so 0 dB provides the highest, widest notch, and higher levels make the notch increasingly narrower and shallower.
<u>L Phase</u>	The phase angle of the left channel LFO relative to the system tempo clock and the right channel phase.
<u>R Phase</u>	The phase angle of the right channel LFO relative to the system tempo clock and the left channel phase.

FXAlg #903 Resonant Filter • FXAlg #904 Dual Res Filter

Stereo and dual-mono 2-pole resonant filters
Allocation Units: 1 (each)

The resonant filter is available as a stereo (linked parameters for left and right) or dual mono (independent controls for left and right). The filter type is selectable and may be one of low pass (i), high pass (ii), band pass (iii), or notch (iv). See the section of this book on FXAlg #900 for diagrams of the filter actions.

The resonant frequency of the filter and the filter resonance level may be adjusted.

Parameters (Resonant Filter):

PAGE 1

Wet/Dry	0 to 100%wet	Out Gain	Off, -79.0 to 24.0 dB
FilterType	Lowpass		
Frequency	16 to 8372 Hz		
Resonance	0 to 50 dB		

Parameters (Dual Res Filter):

PAGE 1

L Wet/Dry	0 to 100%wet	R Wet/Dry	0 to 100%wet
L Output	Off, -79.0 to 24.0 dB	R Output	Off, -79.0 to 24.0 dB

PAGE 2

L FiltType	Lowpass	R FiltType	Highpass
L Freq	16 to 8372 Hz	R Freq	16 to 8372 Hz
LResonance	0 to 50 dB	RResonance	0 to 50 dB

- Wet/Dry The amount of filtered (wet) signal relative to unaffected (dry) signal.
- Out Gain The overall gain or amplitude at the output of the filter.
- FilterType The type of resonant filter to be used. May be one of “Lowpass”, “Highpass”, “Bandpass”, or “Notch”.
- Frequency The frequency of the resonant filter peak (or notch) in Hz. The frequencies correspond to semitone increments.
- Resonance The resonance level of the resonant filter. Resonance sets the level of the resonant peak. In the notch filter, this sets the amount of cut, so 0 dB provides the highest, widest notch, and higher levels make the notch increasingly narrower and shallower.

FXAlg #905: EQ Morpher • FXAlg #906: Mono EQ Morpher

Parallel resonant bandpass filters with parameter morphing
Allocation Units: 4 for EQ Morpher, 2 for Mono EQ Morpher

The EQ Morpher algorithms have four parallel bandpass filters acting on the input signal, whose results are summed for the final output. EQ Morpher is a stereo algorithm for which the left and right channels receive separate processing using the same linked controls. Mono EQ Morpher sums the input left and right channels into a mono signal, so there is only one channel of processing. Both algorithms have output panning. In EQ Morpher, a stereo panner like that on the KDFX Studio INPUT pages is used, which includes a width parameter to control the width of the stereo field. Mono EQ Morpher uses a standard mono panner for positioning the mono signal between the left and right speakers.

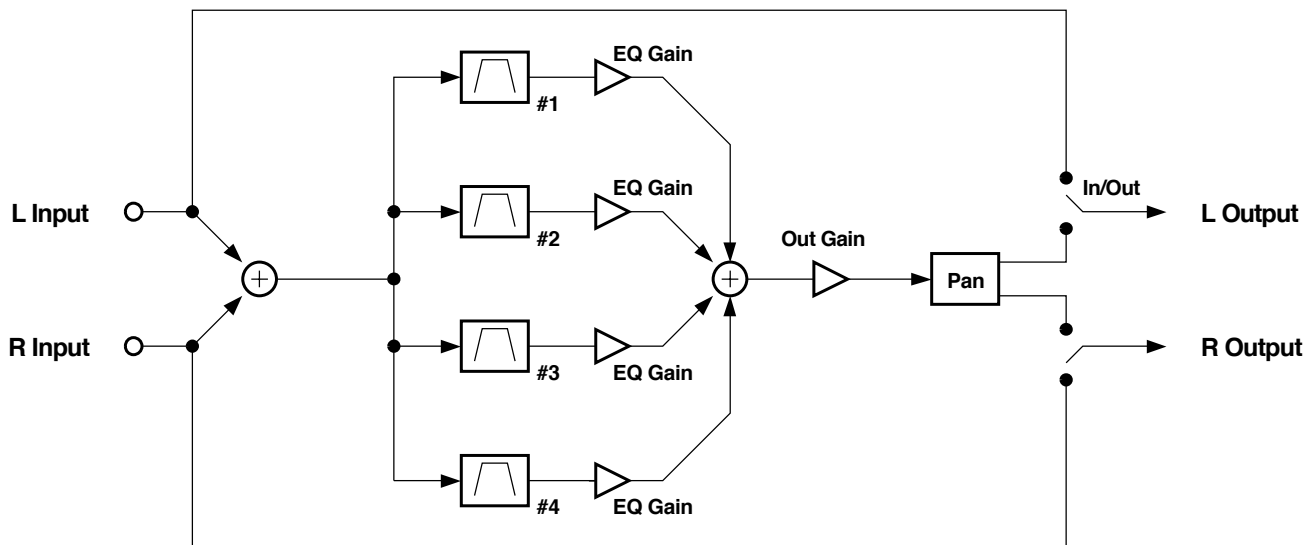

Mono EQ Morpher (EQ Morpher is similar)

For each filter, there are two sets of parameters, A and B. The parameter Morph A>B determines which parameter set is active. When Morph A>B is set to 0%, you are hearing the A parameters; when set to 100%, you are hearing the B parameters. The filters may be gradually moved from A to B and back again by moving the Morph A>B parameter between 0 and 100%.

The four filters are parametric bandpass filters. These are not the usual parametric filters you are familiar with. Normal parametric filters boost or cut the signal at the frequency you specify relative to the signal at other frequencies. The bandpass filters used here pass only signals at the frequency you specify and cut all other frequencies. The gain controls set the levels of each filter's output. Like the normal parametric filters, you have control of the filters' frequencies and bandwidths. The Freq Scale parameters may be used to adjust the A or B filters' frequencies as a group. This allows you to maintain a constant spectral relationship between your filters while adjusting the frequencies up and down. The filters are arranged in parallel and their outputs summed, so the bandpass peaks are added together and the multiple resonances are audible.

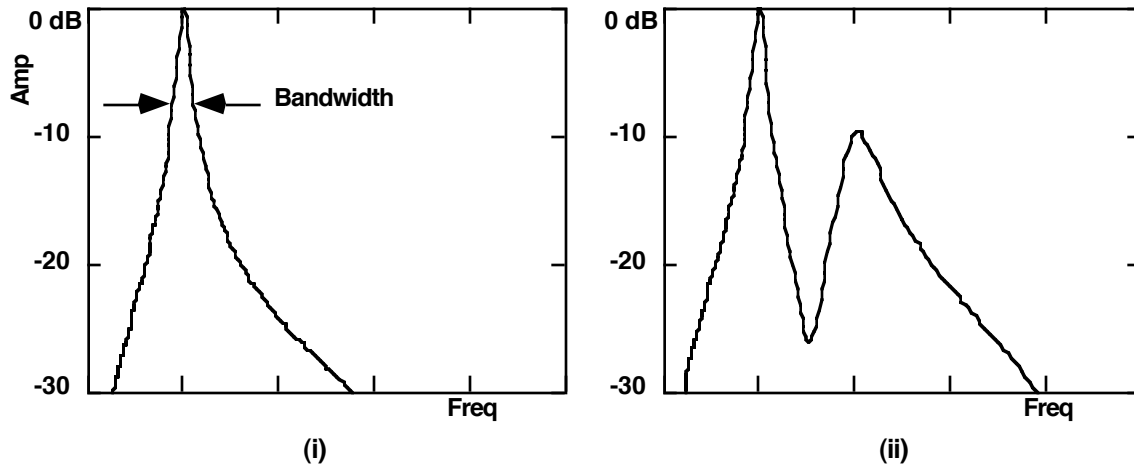

Frequency response of (i) a single bandpass filter, and (ii) the sum of two bandpass filters

Now that we've gone through what the algorithm does, the question becomes "Why are we doing this?" With careful thought to parameter settings, EQ Morph does an excellent job of simulating the resonances of the vocal tract. A buzz or sawtooth signal is a good choice of source material to experiment with the EQ Morphers. Set the Morph A>B parameter to 0%, and find a combination of A filter settings which give an interesting vowel like sound. It may help to start from existing ROM presets. Next set Morph A>B to 100% and set the B parameters to a different vowel-like sound. You can now set up some FXMods on Morph A>B to morph between the two sets of parameters, perhaps using Freq Scale to make it more expressive.

When morphing from the A parameters to the B parameters, A filter #1 moves to B filter #1, A filter #2 moves to B filter #2, and so on. For the most normal and predictable results, it's a good idea not to let the frequencies of the filters cross each other during the morphing. You can ensure this doesn't happen by making sure the four filters are arranged in ascending order of frequencies. Descending order is okay too, provided you choose an order and stick to it.

Parameters:

PAGE 1

In/Out	In or Out	Out Gain	Off, -79.0 to 24.0 dB
Morph A>B	0 to 100%	Out Pan	-100 to 100%
		Out Width*	-100 to 100%
AFreqScale	-8600 to 8600 ct	BFreqScale	-8600 to 8600 ct

*EQ Morpher only, not Mono EQ Morpher.

PAGE 2

A Freq 1	16 to 25088 Hz	B Freq 1	16 to 25088 Hz
A Width 1	0.010 to 5.000 oct	B Width 1	0.010 to 5.000 oct
A Gain 1	-79.0 to 24.0 dB	B Gain 1	-79.0 to 24.0 dB
A Freq 2	16 to 25088 Hz	B Freq 2	16 to 25088 Hz
A Width 2	0.010 to 5.000 oct	B Width 2	0.010 to 5.000 oct
A Gain 2	-79.0 to 24.0 dB	B Gain 2	-79.0 to 24.0 dB

PAGE 3

A Freq 3	16 to 25088 Hz	B Freq 3	16 to 25088 Hz
A Width 3	0.010 to 5.000 oct	B Width 3	0.010 to 5.000 oct
A Gain 3	-79.0 to 24.0 dB	B Gain 3	-79.0 to 24.0 dB
A Freq 4	16 to 25088 Hz	B Freq 4	16 to 25088 Hz
A Width 4	0.010 to 5.000 oct	B Width 4	0.010 to 5.000 oct
A Gain 4	-79.0 to 24.0 dB	B Gain 4	-79.0 to 24.0 dB

- In/Out When set to “In” the algorithm is active; when set to “Out” the algorithm is bypassed.
- Out Gain An overall level control of the EQ Morpher output.
- Out Pan Provides panning of the output signal between left and right output channels. A setting of -100% is panned left and 100% is panned right. For EQ Morph, this is a stereo panner which pans the entire stereo image, the same way the input sends on a KDFX INPUT page are handled, when set to the “SP” mode.
- Out Width The width of the stereo field is controlled by this parameter. A setting of 100% is the same full width as the input signal. At 0% the left and right channels are narrowed to the point of being mono. Negative values reverse the left and right channels. [EQ Morpher only]
- Morph A>B When set to 0% the “A” parameters are controlling the filters, and when set to 100%, the “B” parameters control the filters. Between 0 and 100%, the filters are at interpolated positions. When morphing from A to B settings, the A filter #1 will change to the B filter #1, A filter #2 moves to B filter #2, and so on. This is an excellent candidate for assignment to a real-time KDFX Modulation.
- FreqScale The filter frequencies for the A and B parameter sets may be offset with the FreqScale parameters. After setting the filter parameters, the FreqScale parameters will move each of the four filter frequencies together by the same relative pitch. This, too, is an excellent candidate for assignment to a real-time KDFX Modulation.
- For the two filter sets A & B, there are four filters 1, 2, 3 and 4:
- Freq The center frequency of the bandpass filter peak in Hz. This frequency may be offset by the FreqScale parameter.
- Width The bandwidth of the bandpass filter in octaves. Narrow bandwidths provide the most convincing vocal sounds.
- Gain The level of the bandpass filter output. At 0 dB, a sine wave at the same frequency as the filter will be neither boosted nor cut. At settings greater than 0 dB, the (hypothetical) sine wave is boosted, and below 0 dB the sine wave is cut. Signals at frequencies other than the filter frequency are always cut more than a signal at the filter frequency. The amount that other frequencies are cut depends on the bandwidth of the bandpass filter.

FXAlg #907: Ring Modulator

A configurable ring modulator

Allocation Units: 1

Ring modulation is a simple effect in which two signals are multiplied together. Typically, an input signal is modulated with a simple carrier waveform such as a sine wave or a sawtooth. Since the modulation is symmetric ($a*b = b*a$), deciding which signal is the carrier and which is the modulation signal is a question of perspective. A simple, unchanging waveform is generally considered the carrier.

To see how the ring modulator works, we'll have to go through a little high school math and trigonometry. If you like, you can skip the how's and why's and go straight to the discussion of controlling the algorithm.

Let's look at the simple case of two equal amplitude sine waves modulating each other. Real signals will be more complex, but they will be much more difficult to analyze. The two sine waves generally will be oscillating at different frequencies. A sine wave signal at any time t having a frequency f is represented as $\sin(ft + \phi)$ where ϕ is constant phase angle to correct for the sine wave not being 0 at $t = 0$. The sine wave could also be represented with a cosine function which is a sine function with a 90° phase shift. To simply matters, we will write $A = f_1t + \phi_1$ for one of the sine waves and $B = f_2t + \phi_2$ for the other sine wave. The ring modulator multiplies the two signals to produce $\sin A \sin B$. We can try to find a trigonometric identity for this, or we can just look up in a trigonometry book,

$$2 \sin A \sin B = \cos(A - B) - \cos(A + B).$$

This equation tells us that multiplying two sine waves produces two new sine waves (or cosine waves) at the sum and difference of the original frequencies. The following figure shows the output frequencies (solid lines) for a given input signal pair (dashed lines):

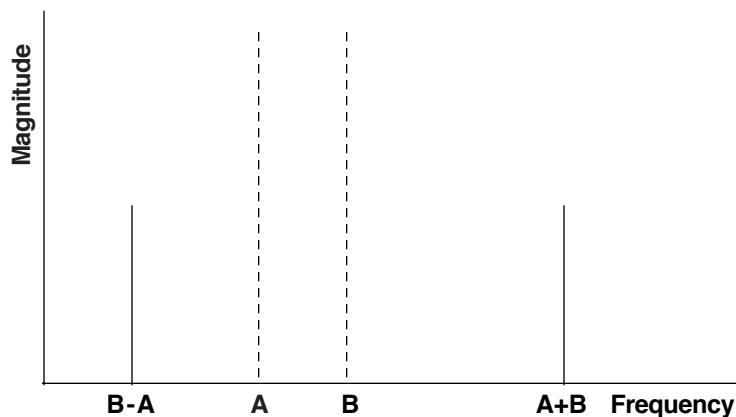

Result of Modulating Two Sine Waves, A and B

This algorithm has two operating modes, set with the Mod Mode parameter. In "L*R" mode, you supply the modulation and carrier signals as two mono signals on the left and right inputs. The output in "L*R" mode is also mono and you may use the L*R Pan parameter to pan the output. The oscillator parameters on parameter pages 2 and 3 will be inactive while in "L*R" mode. The following figure shows the signal flow when in "L*R" mode:

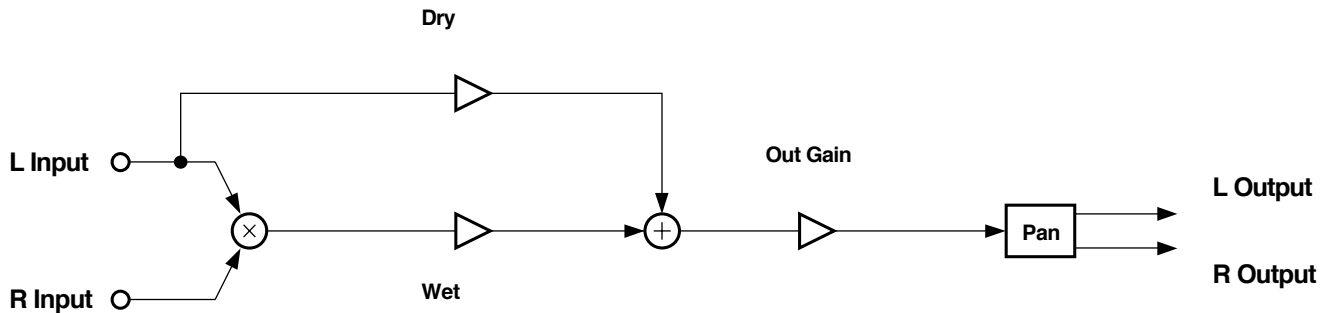

Ring Modulator in "L*R" Mode

The other modulation mode is "Osc". In this mode, the algorithm inputs and outputs are stereo, and the carrier signal for both channels is generated inside the algorithm.

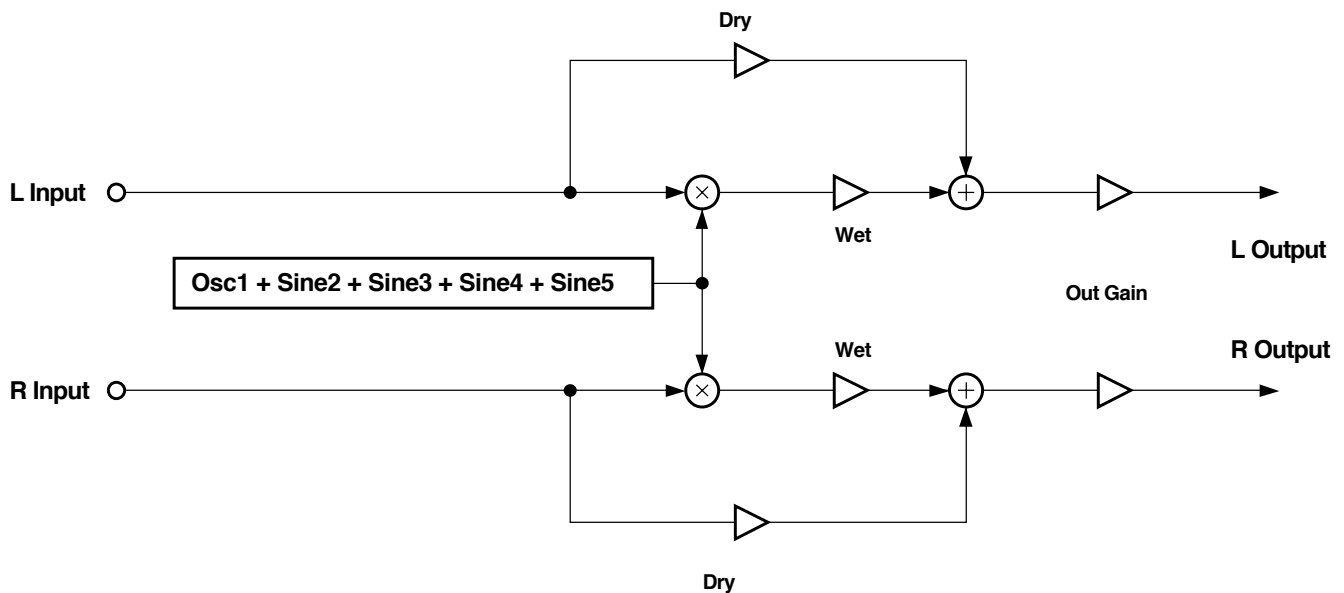

Ring Modulator in "Osc" Mode

The carrier signal is the sum of five oscillators. On all of the oscillators, level and frequency may be set. Four of the oscillators are simple sine waves, while the fifth may be configured to one of a variety of wave shapes. Available shapes are Sine, Saw+, Saw-, Pulse, Tri and Expon. Sine is simply another sine waveform. Tri produces a triangular waveform, and Expon produces a waveform with narrow, sharp peaks which seems to rise exponentially from 0. Pulse produces a series of square pulses where the pulse width can be adjusted with the "Osc1PlsWid" parameter. When pulse width is 50%, the signal is a square wave. The "Osc1PlsWid" parameter is only active when the Pulse waveform is selected. Saw+ and Saw- produce rising and falling sawtooth waveforms.

Smoothing is available to reduce the upper partials of the Pulse and Saw waveforms. The pulse wave, at 50% width, turns into a sine wave when set to 100% smoothing. The sudden change in amplitude of a sawtooth turns into a more gradual slope with smoothing, ending up as a triangle wave when set to 100% smoothing.

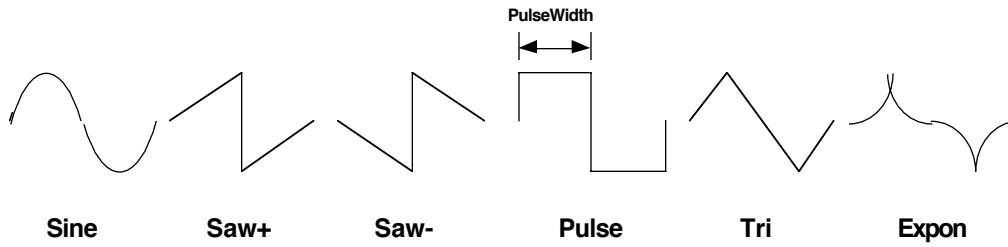

Configurable Wave Shapes (Osc1 only)

Parameters:

PAGE 1

Wet/Dry	0 to 100%wet	Out Gain	Off, -79.0 to 24.0 dB
Mod Mode	L*R or Osc	L*R Gain	Off, -79.0 to 48.0 dB
		L*R Pan	-100 to 100%

PAGE 2

Osc1 Lvl	0 to 100%	Osc1 Freq	16 to 25088 Hz
Osc1 Shape	Sine		
Osc1PlsWid	0 to 100%		
Osc1Smooth	0 to 100%		

PAGE 3

Sine2 Lvl	0 to 100%	Sine2 Freq	16 to 25088 Hz
Sine3 Lvl	0 to 100%	Sine3 Freq	16 to 25088 Hz
Sine4 Lvl	0 to 100%	Sine4 Freq	16 to 25088 Hz
Sine5 Lvl	0 to 100%	Sine5 Freq	16 to 25088 Hz

Wet/Dry The amount of modulated (wet) signal relative to unaffected (dry) signal as a percent. When in "L*R" mode, the left input will be used as the dry signal.

Out Gain The overall gain or amplitude at the output of the effect.

Mod Mode Switches between the two operating modes of the algorithm. The "L*R" mode treats the left and right inputs as the modulator and carrier signals. It does not matter which input is left and which is right except to note that only the left signal will be passed through as dry.

L*R Pan The output panning of the both wet and dry signals. This control is active only in "L*R" mode. -100% is panned fully left, 0% is panned center and 100% is panned right.

Osc1 Lvl The level of the configurable oscillator. 0% is off and 100% is maximum. This parameter is active only in "Osc" mode.

Osc1 Freq The fundamental frequency of the configurable oscillator. The oscillators can be set through the audible frequencies 16-25088 Hz with 1 semitone resolution. This parameter is active only in "Osc" mode.

Osc1Shape Shape selects the waveform type for the configurable oscillator. Choices are Sine, Saw+, Saw-, Pulse, Tri, and Expon. This parameter is active only in "Osc" mode.

<u>Osc1PlsWid</u>	When the configurable oscillator is set to Pulse, the PlsWid parameter sets the pulse width as a percentage of the waveform period. The pulse is a square wave when the width is set to 50%. This parameter is active only in "Osc" mode and when the Pulse waveform is selected.
<u>Osc1Smooth</u>	Smooths the Saw+, Saw-, and Pulse waveforms. For the sawtooth waves, smoothing makes the waveform more like a triangle wave. For the Pulse wave, smoothing makes the waveform more like a sine wave.
<u>Sinen Lvl</u>	The four sine wave oscillators ($n = 2...5$) may have their levels set between 0% (off) and 100% (maximum). This parameter is active only in "Osc" mode.
<u>Sinen Freq</u>	The four sine wave oscillators ($n = 2...5$) may have their frequencies set with this parameter. The oscillators can be set through the audible frequencies 16-25088 Hz with 1 semitone resolution. This parameter is active only in "Osc" mode.

FXAlg #908: Pitcher

Creates pitch from pitched or non-pitched signal

Allocation Units: 1

This algorithm applies a filter which has a series of peaks in the frequency response to the input signal. The peaks may be adjusted so that their frequencies are all multiples of a selectable frequency, all the way up to 24 kHz. When applied to a sound with a noise-like spectrum (white noise, with a flat spectrum, or cymbals, with a very dense spectrum of many individual components), an output is produced which sounds very pitched, since most of its spectral energy ends up concentrated around multiples of a fundamental frequency.

If the original signal has no significant components at the desired pitch or harmonics, the output level remains low. The left and right inputs are processed independently with common controls of pitch and weighting. Applying Pitcher to sounds such as a single sawtooth wave will tend to not produce much output, unless the sawtooth frequency and the Pitcher frequency match or are harmonically related, because otherwise the peaks in the input spectrum won't line up with the peaks in the Pitcher filter. If there are enough peaks in the input spectrum (obtained by using sounds with noise components, or combining lots of different simple sounds, especially low pitched ones, or several distorting a simple sound) then Pitcher can do a good job of imposing its pitch on the sound.

The four weight parameters, named "Odd Wts", "Pair Wts", "Quatr Wts" and "Half Wts", control the exact shape of the frequency response of Pitcher. An exact description of what each one does is, unfortunately, impossible, since there is a great deal of interaction between them. Here are some examples with a Pitch setting of 1 kHz, which is close to a value of C6. Weight settings are listed in brackets following this format: [Odd, Pair, Quartr, Half].

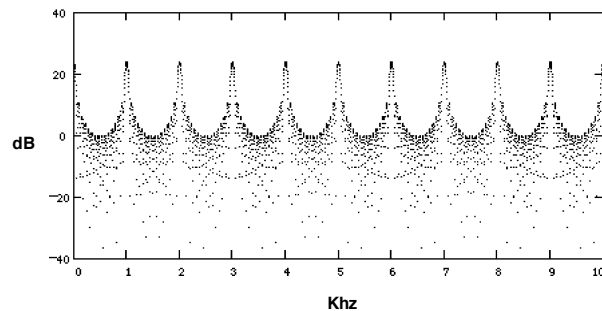

[OPQH=100, 100, 100, 100] All peaks are exact multiples of the fundamental frequency set by the Pitch parameter. This setting gives the most "pitchiness" to the output.

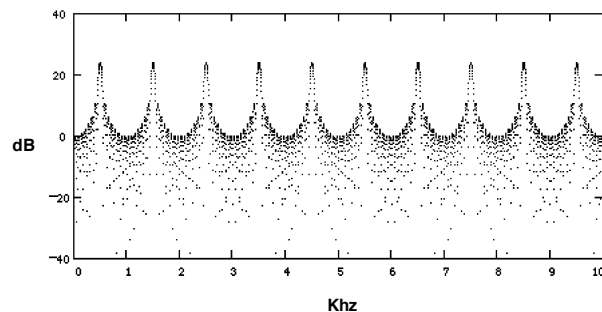

[OPQH= -100, 100, 100, 100] Peaks are odd multiples of a frequency one octave down from the Pitch setting. This gives a hollow, square-wavey sound to the output.

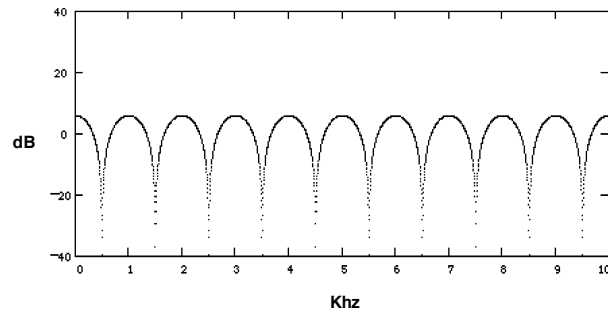

[OPQH=100, 0, 0, 0] Deeper notches between wider peaks

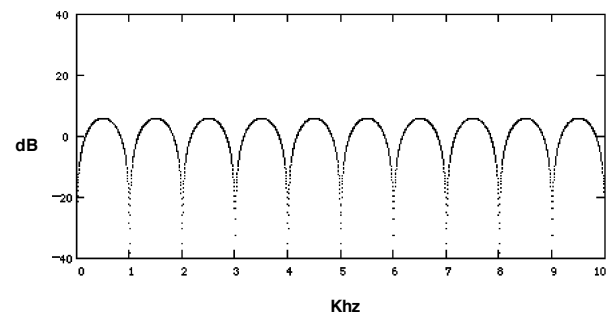

[OPQH=-100, 0, 0, 0] Peaks on odd harmonic multiples and notches on even harmonic multiples of a frequency one octave down from the Pitch setting.

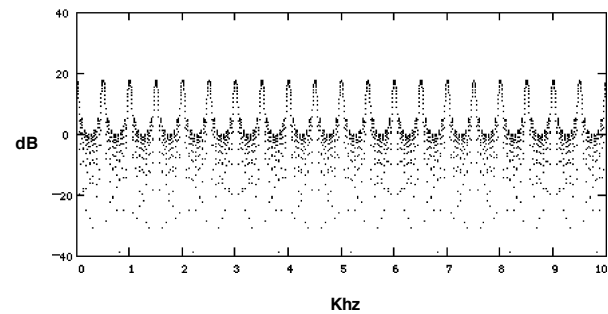

[OPQH=0, 100, 100, 100] Like [100,100,100,100], except that all the peaks are at (all) multiples of half the Pitch frequency.

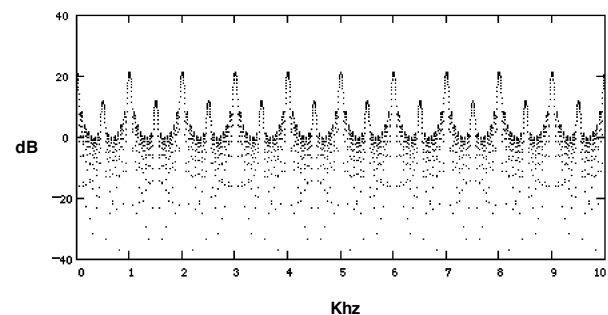

[OPQH=50,100,100,100] Halfway between [0,100,100,100] and [100,100,100,100].

FXAlg #908: Pitcher

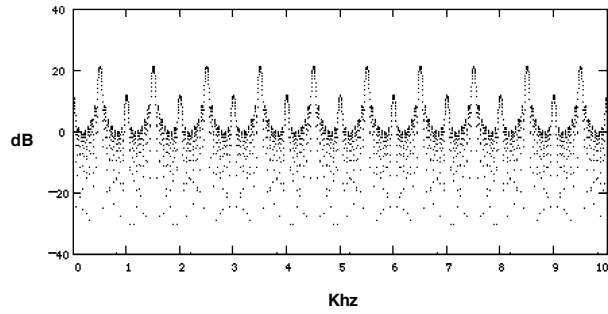

[OPQH= -50,100,100,100] Halfway between [0,100,100,100] and [-100,100,100,100].
If the "Odd" parameter is modulated with an FXMOD, then one can morph smoothly between the [100,100,100,100] and [-100,100,100,100] curves.

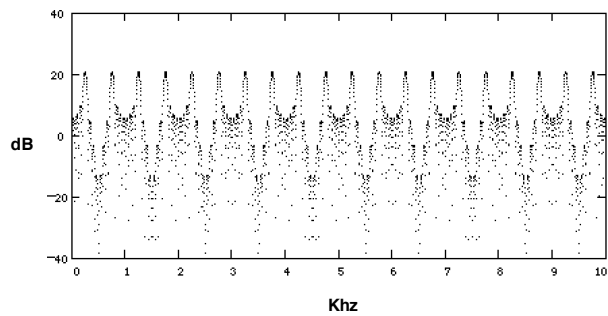

[OPQH=100, -100, 100, 100]

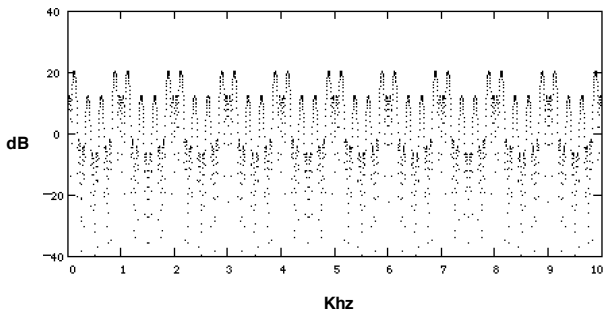

[OPQH=100, 100, -100, 100]

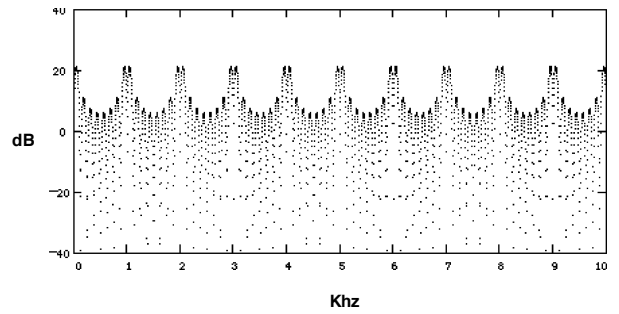

[OPQH=100, 100, 100, -100]

The other 1,632,240,792 response curves have been omitted in the interest of brevity.

Parameters:

PAGE 1

Wet/Dry	0 to 100%wet	Out Gain	Off, -79.0 to 24.0 dB
Pitch	C-1 to G9	Ptch Offst	-12.0 to 12.0 ST
Odd Wts	-100 to 100%	Quartr Wts	-100 to 100%
Pair Wts	-100 to 100%	Half Wts	-100 to 100%

- Wet/Dry The relative amount of input signal and effected signal that is to appear in the final effect output mix. When set to 0%, the output is taken only from the input (dry). When set to 100%, the output is all wet.
- Out Gain The overall gain or amplitude at the output of the effect.
- Pitch The fundamental pitch imposed upon the input. Values are in MIDI note numbers.
- Ptch Offst An offset from the pitch frequency in semitones. This is also available for adding an additional continuous controller mod like pitch bend.
- Odd Wts, Pair Wts, Quartr Wts, Half Wts These parameters control the exact shape of the frequency response of Pitcher. An exact description of what each one does is, unfortunately, impossible, since there is a great deal of interaction between them. For examples, examine the figures above.

FXAlg #909: Super Shaper

Ridiculous shaper

Allocation Units: 1

The Super Shaper algorithm packs two and a half times the number of shaping loops, and 8 times the gain of the shaper found in VAST. Refer to the section on shapers in the *K2500 Performance Guide* for an overview of VAST shaper.

Setting Super Shaper amount under 1.00x will produce the same non-linear curve as that found in the VAST shaper. At values above 1.00x where the VAST shaper will pin at zero, the Super Shaper provides 6 more sine intervals before starting to zero-pin at 2.50x. The maximum shaper amount for Super Shaper is 32.00x.

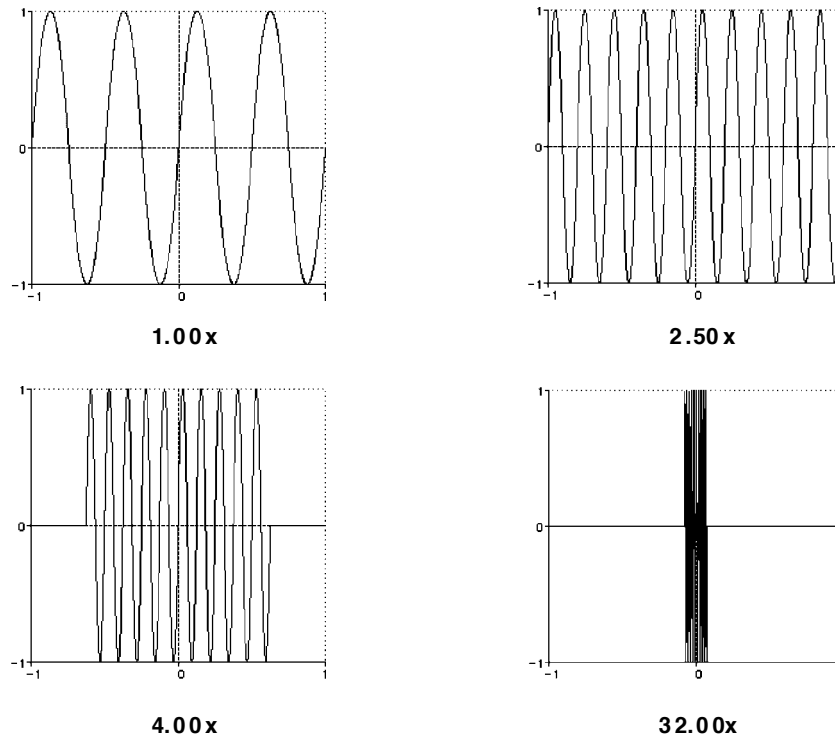

Super Shaper at various Amounts.

Parameters:

PAGE 1

Wet/Dry	-100 to 100%	Out Gain	Off, -79.0 to 24.0 dB
Amount	0.10 to 32.00 x		

- Wet/Dry The relative amount of input signal and effected signal that is to appear in the final effect output mix. When set to 0%, the output is taken only from the input (dry). When set to 100%, the output is all wet. Negative values polarity-invert the wet signal.
- Out Gain The overall gain or amplitude at the output of the effect.
- Amount Adjusts the shaper intensity.

FXAlg #910: 3 Band Shaper

3-band shaper Allocation Units: 2

The 3 Band Shaper non-destructively splits the input signal into 3 separate bands using 1 pole (6dB/oct) filters, and applies a VAST-type shaper to each band separately. Refer to the *K2500 Performance Guide* for an overview of VAST shaping. The cutoff frequencies for these filters are controlled with the CrossOver1 and CrossOver2 parameters. The low band contains frequencies from 0 Hz (dc) to the lower of the two CrossOver settings. The mid band contains frequencies between the 2 selected frequencies, and the hi band contains those from the higher of the two CrossOver settings up to 24kHz.

Each frequency band has an enable switch for instantly bypassing any processing for that band, and a Mix control for adjusting the level of each band that is mixed at the output. negative Mix values polarity-invert that band. The shaper Amt controls provide the same type of shaping as VAST shapers, but can go to 6.00x.

Parameters:

PAGE 1

Wet/Dry	-100 to 100%	Out Gain	Off, -79.0 to 24.0 dB
CrossOver1	17 to 25088 Hz		
CrossOver2	17 to 25088 Hz		

PAGE 2

Lo Enable	On or Off	Lo Enable	On or Off
Lo Amt	0.10 to 6.00x	Lo Amt	0.10 to 6.00x
Lo Mix	-100 to 100%	Lo Mix	-100 to 100%
Mid Enable	On or Off		
Mid Amt	0.10 to 6.00x		
Mid Mix	-100 to 100%		

In/Out When set to "In" the effect is active; when set to "Out" the effect is bypassed.

Out Gain The overall gain or amplitude at the output of the effect.

CrossOver1 Adjusts one of the -6dB crossover points at which the input signal will be divided into the high, mid and low bands.

CrossOver2 Adjusts the other -6dB crossover points at which the input signal will be divided into the high, mid and low bands.

Lo Enable, Mid Enable, Hi Enable Turns processing for each band on or off. Turning each of the 3 bands Off results in a dry output signal.

Lo Amt, Mid Amt, Hi Amt Adjusts the shaper intensity for each band.

Lo Mix, Mid Mix, Hi Mix Adjusts the level that each band is summed together as the wet signal. Negative values polarity-invert the particular bands signal.

FXAlg #911: Mono LaserVerb • FXAlg #912: LaserVerb Lite • FXAlg #913: LaserVerb

A bizarre reverb with a falling buzz

Allocation Units: 1 for Mono LaserVerb; 2 for LaserVerb Lite; 3 for LaserVerb

LaserVerb is a new kind of reverb sound that has to be heard to be believed! When it is fed an impulsive sound such as a snare drum, LaserVerb plays the impulse back as a delayed train of closely spaced impulses, and as time passes, the spacing between the impulses gets wider. The close spacing of the impulses produces a discernible buzzy pitch which gets lower as the impulse spacing increases. The following figure is a simplified representation of the LaserVerb impulse response. (An impulse response of a system is what you would see if you had an oscilloscope on the system output and you gave the system an impulse or a spike for an input.)

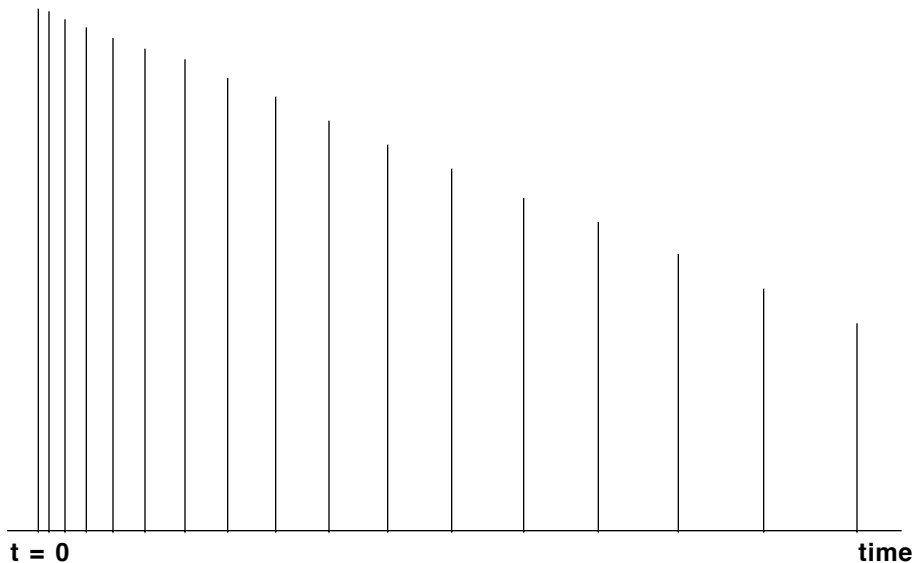

Simplified Impulse Response of LaserVerb

With appropriate parameter settings this effect produces a descending buzz or whine somewhat like a diving airplane or a siren being turned off. The descending buzz is most prominent when given an impulsive input such as a drum hit. When used as a reverb, it tends to be highly metallic and has high pitched tones at certain parameter settings. To get the descending buzz, start with about half a second of delay, set the Contour parameter to a high value (near 1), and set the HF Damping to a low value (at or near 0). The Contour parameter controls the overall shape of the LaserVerb impulse response. At high values the response builds up very quickly and decays slowly. As the Contour value is reduced, the decay becomes shorter and the sound takes longer to build up. At a setting of zero, the response degenerates to a simple delay.

The Spacing parameter controls the initial separation of impulses in the impulse response and the rate of their subsequent separation. Low values result in a high initial pitch (impulses are more closely spaced) and takes longer for the pitch to go down.

The output from LaserVerb can be fed back to the input. By turning up the feedback, the duration of the LaserVerb sound can be greatly extended. Cross-coupling may also be used to move the signal between left and right channels, producing a left/right ping-pong effect at the most extreme settings.

The 2-PAU version is a sparser version than the 3-PAU version. Its buzzing is somewhat coarser. The 1-PAU version is like the 2-PAU version except the two input channels are summed and run through a single mono LaserVerb. The 1-PAU version does not have the cross-coupling control but does have output panning.

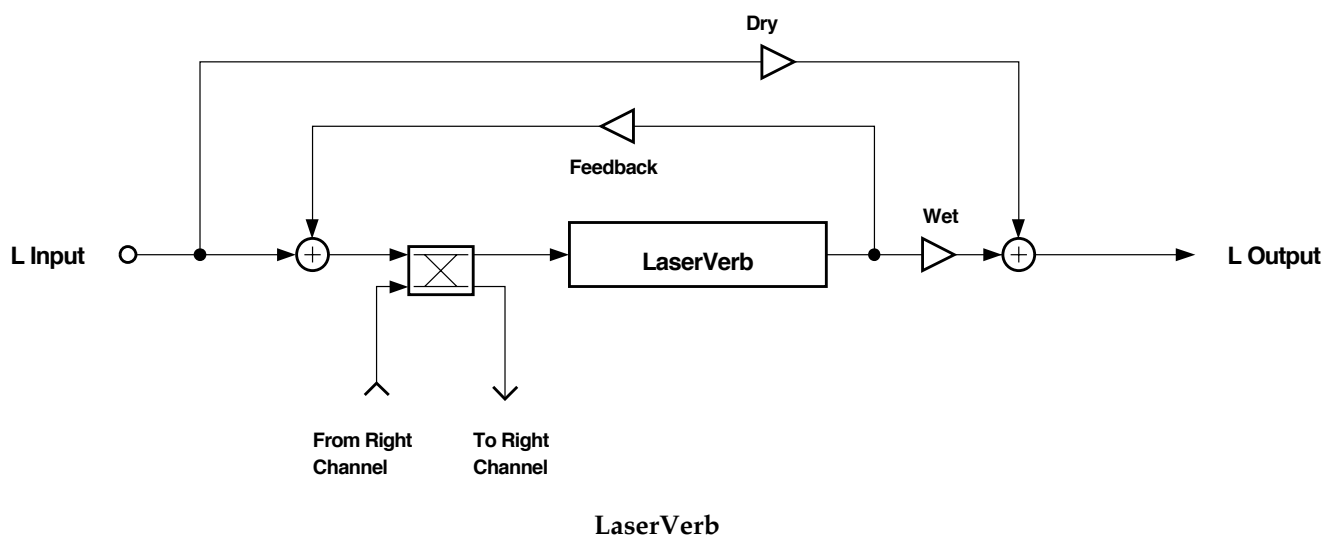

Parameters:

PAGE 1 - LaserVerb and LaserVerb Lite

Wet/Dry	0 to 100%wet	Out Gain	Off, -79.0 to 24.0dB
Fdbk Lvl	0 to 100%		
Xcouple	0 to 100%		
HF Damping	16 to 25088Hz		

PAGE 1 - Mono LaserVerb

Wet/Dry	0 to 100%wet	Out Gain	Off, -79.0 to 24.0dB
Fdbk Lvl	0 to 100%	Pan	-100 to 100%
HF Damping	16 to 25088Hz		

PAGE 2

Dly Coarse	0 to 5000ms	Contour	0.0 to 100.0%
Dly Fine	-20.0 to 20.0ms		
Spacing	0.0 to 40.0samp		

Wet/Dry The amount of reverbed (wet) signal relative to unaffected (dry) signal.

Out Gain The overall gain or amplitude at the output of the effect.

<u>Fdbk Lvl</u>	The percentage of the reverb output to feed back or return to the reverb input. Turning up the feedback is a way to stretch out the duration of the reverb, or, if the reverb is set to behave as a delay, to repeat the delay. The higher feedback is set, the longer the decay or echo will last.
<u>Xcouple</u>	LaserVerb & LaserVerb Lite are stereo effects. The cross-coupling control lets you send the sum of the input and feedback from one channel to its own LaserVerb effect (0% cross coupling) or to the other channel's effect (100% cross coupling) or somewhere in between. This control is not available in Mono LaserVerb.
<u>HF Damping</u>	The damping of high frequencies relative to low frequencies. When set to the highest frequency (25088 Hz), there is no damping and all frequencies decay at the same rate. At lower frequency settings, high frequency signal components will decay faster than low frequency components. If set too low, everything will decay almost immediately.
<u>Pan</u>	The Pan control is available in the Mono LaserVerb. The left and right inputs get summed to mono, the mono signal passes through the LaserVerb, and the final mono output is panned to the left and right outputs. Panning ranges from -100% (fully left), through 0% (centered), through to 100% (fully right).
<u>Dly Coarse</u>	You can set the overall delay length from 0 to 2 seconds (3 PAU) or 0 to 1.3 seconds (2 PAU). Lengthening the delay will increase the duration or decay time of the reverb. To reduce LaserVerb to a simple delay, set the Contour and Feedback controls to 0. Use a delay of about half a second as a starting point.
<u>Dly Fine</u>	The delay fine adjust is added to the delay coarse adjust to provide a delay resolution down to 0.1 ms.
<u>Spacing</u>	Determines the starting pitch of the descending buzz and how fast it descends. The Spacing parameter sets the initial separation of impulses in the impulse response and subsequent rate of increasing impulse separation. The spacing between impulses is given in samples and may be a fraction of a sample. (A sample is the time between successive digital words which is 20.8 μ s or 1/48000 seconds.) For low values, the buzz starts at high frequencies and drops slowly. At high values the buzz starts at a lower pitch and drops rapidly.
<u>Contour</u>	Controls the overall envelope shape of the reverb. When set to a high value, sounds passed through the reverb start at a high level and slowly decay. As the control value is reduced, it takes some time for the effect to build up before decaying. At a value of around 34, the reverb is behaving like a reverse reverb, building up to a hit. When the Contour is set to zero, LaserVerb is reduced to a simple delay.

FXAlg #950: HardKneeCompress • FXAlg #951: SoftKneeCompress

Stereo hard- and soft-knee signal-compression algorithms *Allocation Units: 1*

The stereo hard- and soft-knee compressors are very similar algorithms and provide identical parameters and user interface. Both algorithms compress (reduce) the signal level when the signal exceeds a threshold. The amount of compression is expressed as a ratio. The compression ratio is the inverse of the slope of the compressor input/output characteristic. The amount of compression is based on the sum of the magnitudes of the left and right channels. A compression ratio of 1:1 will have no effect on the signal. An infinite ratio will compress all signal levels above the threshold level to the threshold level (zero slope). For ratios between infinity and 1:1, increasing the input will increase the output, but by less than it would if there was no compression. The threshold is expressed as a decibel level relative to digital full-scale (dBFS) where 0 dBFS is digital full-scale and all other available values are negative.

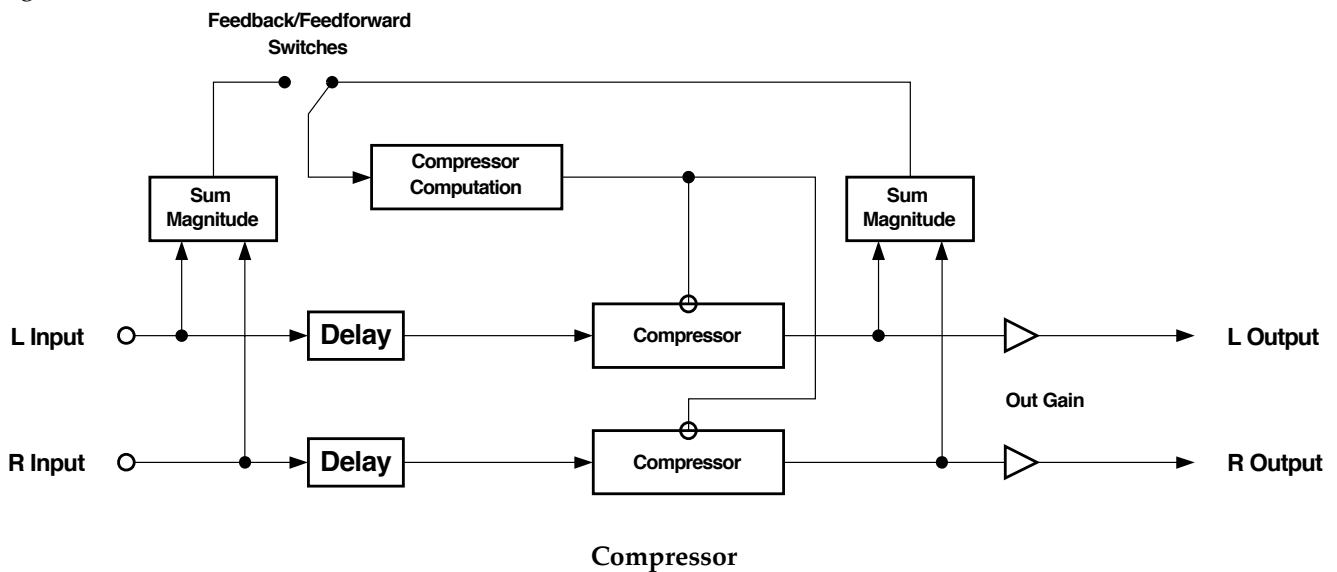

In the hard-knee compressor, there is a sudden transition from uncompressed to compressed at the compression threshold. In the soft-knee compressor there is a more gradual transition from compressed to unity gain.



To determine how much to compress the signal, the compressor must measure the signal level. Since musical signal levels will change over time, the compression amounts must change as well. You can control the rate at which compression changes in response to changing signal levels with the attack and release time controls. With the attack time, you set how fast the compressor responds to increased levels. At long attack times, the signal may over-shoot the threshold level for some time before it becomes fully compressed, while at short attack times, the compressor will rapidly clamp down on the level. The release time controls how long it takes the compressor to respond to a reduction in signal levels. At long release times, the signal may stay compressed well after the signal falls below threshold. At short release times, the compressor will open up almost as soon as the signal drops.

For typical compressor behavior, the attack time is considerably shorter than the release time. At very short attack and release times, the compressor is almost able to keep up with the instantaneous signal levels and the algorithm will behave more like distortion than compression. In addition to the attack and release times, there is another time parameter: "SmoothTime". The smoothing parameter will increase both the attack and release times, although the effect is significant only when its time is longer than the attack or release time. Generally the smoothing time should be kept at or shorter than the attack time.

You have the choice of using the compressors in feed-forward or feedback configuration. For feed-forward, set the FdbkComprs parameter to "Out"; for feedback compression, set it to "In". The feed-forward configuration uses the input signal as the side-chain source. The feedback compressor on the other hand uses the compressor output as the side-chain source. Feedback compression tends to be more subtle, but you cannot get an instant attack.

In the feed-forward configuration, the signal being compressed may be delayed relative to the side chain compression processing. The delay allows the signal to start being compressed just before an attack transient arrives. Since the side chain processing "knows" what the input signal is going to be before the main signal path does, it can tame down an attack transient by compressing the attack before it actually happens. In the feedback configuration, the delay affects both the main signal and the side chain, and so is of limited usefulness.

A meter is provided to display the amount of gain reduction that is applied to the signal as a result of compression.

Parameters:

PAGE 1

In/Out	In or Out	Out Gain	Off, -79.0 to 24.0 dB
FdbkComprs	In or Out		

PAGE 3

Atk Time	0.0 to 228.0 ms	Ratio	1.0:1 to 100:1, Inf:1
Rel Time	0 to 3000 ms	Threshold	-79.0 to 0.0dB
SmoothTime	0.0 to 228.0 ms	MakeUpGain	Off, -79.0 to 24.0 dB
Signal Dly	0.0 to 25.0ms		
Reduction			
-dB 40 20 12 8 6 4 2 0			

- In/Out When set to "In" the compressor is active; when set to "Out" the compressor is bypassed.
- Out Gain Compressing the signal causes a reduction in signal level. To compensate, the output gain parameter may be used to increase the gain by as much as 24 dB. Note that the Out Gain parameter does not control the signal level when the algorithm is set to "Out".

<u>FdbkComprs</u>	A switch to set whether the compressor side chain is configured for feed-forward (Out) or feedback (In).
<u>Atk Time</u>	The time for the compressor to start to cut in when there is an increase in signal level (attack) above the threshold.
<u>Rel Time</u>	The time for the compressor to stop compressing when there is a reduction in signal level (release) from a signal level above the threshold.
<u>SmoothTime</u>	A lowpass filter in the control signal path. It is intended to smooth the output of the expander's envelope detector. Smoothing will affect the attack or release times when the smoothing time is longer than one of the other times.
<u>Signal Dly</u>	For the feed-forward setting, Signal Dly is the time in ms by which the input signal should be delayed with respect to compressor side chain processing (i.e. side chain pre-delay). This allows the compression to appear to take effect just before the signal actually rises. For feedback compression, this parameter causes both the side-chain and main signal path to be delayed together.
<u>Ratio</u>	The compression ratio. High ratios are highly compressed; low ratios are moderately compressed.
<u>Threshold</u>	The threshold level in dBFS (decibels relative to full scale) above which the signal begins to be compressed.
<u>MakeUpGain</u>	Provides an additional control of the output gain. The Out Gain and MakeUpGain controls are additive (in decibels) and together may provide a maximum of 24 dB boost to offset gain reduction due to compression.

FXAlg #952: Expander

A stereo expansion algorithm

Allocation Units: 1

This algorithm expands the signal (reduces the signal's gain) when the signal falls below the expansion threshold. The amount of expansion is based on the larger magnitude of the left and right channels. The amount of expansion is expressed as an expansion ratio. Expanding a signal reduces its level below the threshold. The expansion ratio is the inverse of the slope of the expander input/output characteristic. An expansion ratio of 1:1 will have no effect on the signal. A zero ratio (1:∞), will expand all signal levels below the threshold level to the null or zero level. (Maximum expansion for this expander is 1:17.) Thresholds are expressed as a decibel level relative to digital full-scale (dBFS), where 0 dBFS is digital full-scale and all other available values are negative.

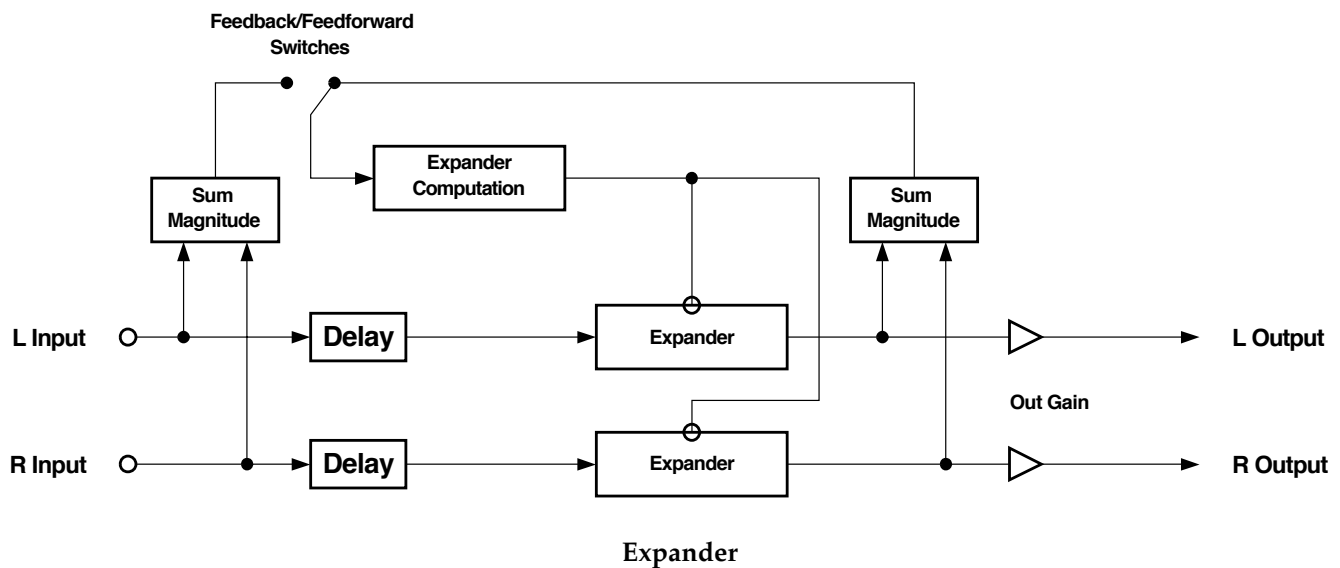

To determine how much to expand the signal, the expander must measure the signal level. Since musical signal levels will change over time, the expansion amounts must change as well. You can control how fast the expansion changes in response to changing signal levels with the attack and release time controls.

The attack time is defined as the time for the expansion to turn off when the signal rises above the threshold. This time should be very short for most applications. The expander release time is the time for the signal to expand down after the signal drops below threshold. The expander release time may be set quite long. An expander may be used to suppress background noise in the absence of signal, thus typical expander settings use a fast attack (to avoid losing real signal), slow release (to gradually fade out the noise), and the threshold set just above the noise level. You can set just how far to drop the noise with the expansion ratio.

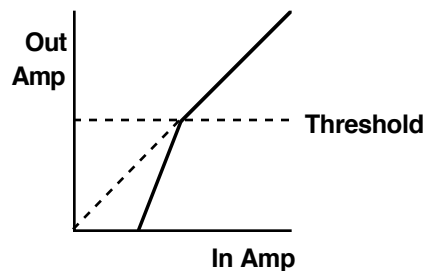

Expansion Transfer Characteristic

The signal being expanded may be delayed relative to the side chain processing. The delay allows the signal to stop being expanded just before an attack transient arrives. Since the side chain processing “knows” what the input signal is going to be before the main signal path does, it can tame down an attack transient by releasing the expander before the attack actually happens. A meter is provided to display the amount of gain reduction that is applied to the signal as a result of expansion.

Parameters:

PAGE 1

In/Out	In or Out	Out Gain	Off, -79.0 to 24.0 dB
---------------	------------------	-----------------	------------------------------

PAGE 2

Atk Time	0.0 to 228.0 ms	Ratio	1:1.0 to 1:17.0
Rel Time	0 to 3000 ms	Threshold	-79.0 to 0.0 dB
SmoothTime	0.0 to 228.0 ms	MakeUpGain	Off, -79.0 to 24.0 dB
Signal Dly	0.0 to 25.0 ms		
Reduction			
-dB 40 20 12 8 6 4 2 0			

<u>In/Out</u>	When set to “In” the expander is active; when set to “Out” the expander is bypassed.
<u>Out Gain</u>	The output gain parameter may be used to increase the gain by as much as 24 dB, or reduce the gain to nothing. Note that the Out Gain parameter does not control the signal level when the algorithm is set to “Out”.
<u>Atk Time</u>	The time for the expander to increase the gain of the signal (turns off the expander) after the signal rises above threshold.
<u>Rel Time</u>	The time for the expander to reduce the signal level when the signal drops below the threshold (turning on expansion).
<u>SmoothTime</u>	A lowpass filter in the control signal path. It is intended to smooth the output of the expander’s envelope detector. Smoothing will affect the attack or release times when the smoothing time is longer than one of the other times.
<u>Signal Dly</u>	The time in ms by which the input signal should be delayed with respect to expander side chain processing (i.e. side chain pre-delay). This allows the expansion to appear to turn off just before the signal actually rises.
<u>Ratio</u>	The expansion ratio. High values ($\leq 1:17$) are highly expanded, low values ($> 1:1.0$) are moderately expanded.
<u>Threshold</u>	The expansion threshold level in dBFS (decibels relative to full scale) below which the signal begins to be expanded.
<u>MakeUpGain</u>	Provides an additional control of the output gain. The Out Gain and MakeUpGain controls are additive (in decibels) and together may provide a maximum of 24 dB boost to offset gain reduction due to expansion.

FXAlg #953: Compress w/SC EQ

Stereo soft-knee compression algorithm with filtering in the side chain

Allocation Units: 2

The Compress w/SC EQ algorithm is the same as the SoftKneeCompress algorithm except that equalization has been added to the side chain signal path. The equalization to the side chain includes bass and treble shelf filters and a parametric mid-range filter.

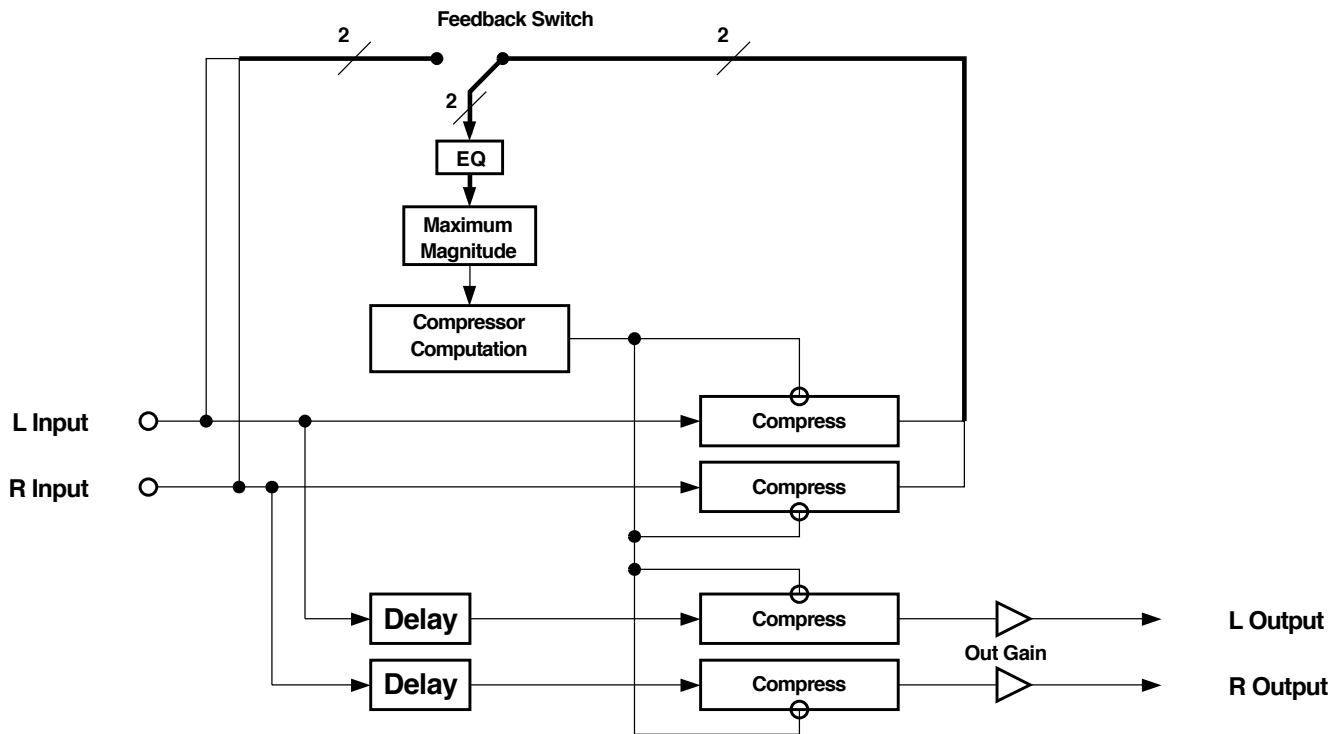

Compressor with side chain equalization.

Using side chain equalization allows you to compress your signal based on the spectral (frequency) content of your signal. For example, by boosting the treble shelf filter, you can compress the signal only when there are a lot of high frequencies present. This technique is often called "de-essing", because it is useful for removing excess sibilance from vocals.

Parameters:

PAGE 1

In/Out	In or Out	Out Gain	Off, -79.0 to 24.0 dB
FdbkComprs	In or Out		

PAGE 2

Atk Time	0.0 to 228.0 ms	Ratio	1.0:1 to 100.0:1, Inf:1
Rel Time	0 to 3000 ms	Threshold	-79.0 to 24.0 dB
SmoothTime	0.0 to 228.0 ms	MakeUpGain	Off, -79.0 to 24.0 dB
Signal Dly	0.0 to 25.0 ms		
Reduction			
-dB 40 20 12 8 6 4 2 0			

PAGE 3

SCBassGain	-79.0 to 24.0 dB	SCTrebGain	-79.0 to 24.0 dB
SCBassFreq	16 to 25088 Hz	SCTrebFreq	16 to 25088 Hz
SCMidGain	-79.0 to 24.0 dB		
SCMidFreq	16 to 25088 Hz		
SCMidWidth	0.010 to 5.000 oct		

<u>In/Out</u>	When set to “In” the compressor is active; when set to “Out” the compressor is bypassed.
<u>Out Gain</u>	Compressing the signal causes a reduction in signal level. To compensate, the output gain parameter may be used to increase the gain by as much as 24 dB. Note that the Out Gain parameter does not control the signal level when the algorithm is set to “Out”.
<u>FdbkComprs</u>	A switch to set whether the compressor side chain is configured for feed-forward (Out) or feedback (In).
<u>Atk Time</u>	The time for the compressor to start to cut in when there is an increase in signal level (attack) above the threshold.
<u>Rel Time</u>	The time for the compressor to stop compressing when there is a reduction in signal level (release) from a signal level above the threshold.
<u>SmoothTime</u>	A lowpass filter in the control signal path. It is intended to smooth the output of the expander’s envelope detector. Smoothing will affect the attack or release times when the smoothing time is longer than one of the other times.
<u>Signal Dly</u>	The time in ms by which the input signal should be delayed with respect to compressor side chain processing (i.e. side chain pre-delay). This allows the compression to appear to take effect just before the signal actually rises.
<u>Ratio</u>	The compression ratio. High ratios are highly compressed; low ratios are moderately compressed.
<u>Threshold</u>	The threshold level in dBFS (decibels relative to full scale) above which the signal begins to be compressed.
<u>MakeUpGain</u>	Provides an additional control of the output gain. The Out Gain and MakeUpGain controls are additive (in decibels) and together may provide a maximum of 24 dB boost to offset gain reduction due to compression.

FXAlg #953: Compress w/SC EQ

<u>SCBassGain</u>	The amount of boost or cut that the side chain bass shelving filter should apply to the low frequency signals in dB. Every increase of 6 dB approximately doubles the amplitude of the signal. Positive values boost the bass signal below the specified frequency. Negative values cut the bass signal below the specified frequency.
<u>SCBassFreq</u>	The center frequency of the side chain bass shelving filter in intervals of one semitone.
<u>SCTrebGain</u>	The amount of boost or cut that the side chain treble shelving filter should apply to the high frequency signals in dB. Every increase of 6 dB approximately doubles the amplitude of the signal. Positive values boost the treble signal above the specified frequency. Negative values cut the treble signal above the specified frequency.
<u>SCTrebFreq</u>	The center frequency of the side chain treble shelving filters in intervals of one semitone.
<u>SCMidGain</u>	The amount of boost or cut that the side chain parametric mid filter should apply in dB to the specified frequency band. Every increase of 6 dB approximately doubles the amplitude of the signal. Positive values boost the signal at the specified frequency. Negative values cut the signal at the specified frequency.
<u>SCMidFreq</u>	The center frequency of the side chain parametric mid filter in intervals of one semitone. The boost or cut will be at a maximum at this frequency.
<u>SCMidWidth</u>	The bandwidth of the side chain parametric mid filter may be adjusted. You specify the bandwidth in octaves. Small values result in a very narrow filter response. Large values result in a very broad response.

FXAlg #954: Compress/Expand • FXAlg #955: Comp/Exp + EQ

A stereo soft-knee compression and expansion algorithm with and without equalization

Allocation Units: 2 for Compress/Expand; 3 for Cmp/Exp + EQ

These are stereo compressor and expander algorithms. One version is followed by equalization and the other is not. The algorithms compress the signal level when the signal exceeds a compression threshold and expands the signal when the signal falls below the expansion threshold. The amount of compression and/or expansion is based on the larger magnitude of the left and right channels.

The amount of compression is expressed as a ratio. The compression ratio is the inverse of the slope of the compressor input/output characteristic. A compression ratio of 1:1 will have no effect on the signal. An infinite ratio, will compress all signal levels above the threshold level to the threshold level (zero slope). For ratios in between infinite and 1:1, increasing the input will increase the output, but by less than it would if there was no compression. The compressor is a soft-knee compressor, so the transition from compressed to linear is quite gradual.

The amount of expansion is expressed as an expansion ratio. Expanding a signal reduces its level below the threshold. The expansion ratio is the inverse of the slope of the expander input/output characteristic. An expansion ratio of 1:1 will have no effect on the signal. A zero ratio (1:∞), will expand all signal levels below the threshold level to the null or zero level. (This expander expands to 1:17 at most.) Thresholds are expressed as a decibel level relative to digital full-scale (dBFS) where 0 dBFS is digital full-scale and all other available values are negative.

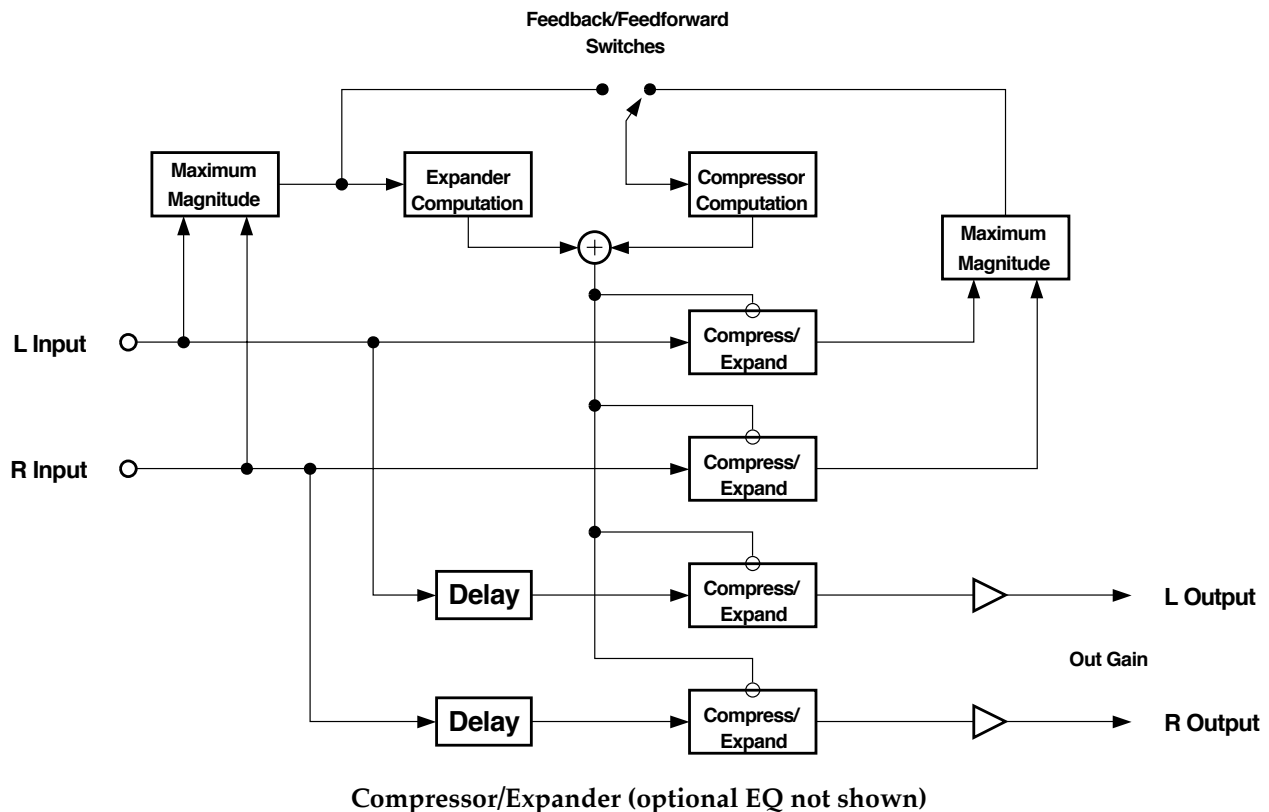

To determine how much to compress or expand the signal, the compressor/expander must measure the signal level. Since musical signal levels will change over time, the compression and expansion amounts must change as well. You can control how fast the compression or expansion changes in response to changing signal levels with the attack and release time controls. Compression and expansion have separate controls.

First consider the compressor. With the attack time, you set how fast the compressor responds to increased levels. At long attack times, the signal may overshoot the threshold level for some time interval before it becomes fully compressed, while at short attack times, the compressor will rapidly clamp down on the level. The release time controls how long it takes the compressor to respond to a reduction in signal levels. At long release times, the signal may stay compressed well after the signal falls below threshold. At short release times, the compressor will open up almost as soon as the signal drops.

For typical compressor behavior, the attack time is considerably shorter than the release time. At very short attack and release times, the compressor is almost able to keep up with the instantaneous signal levels and the algorithm will behave more like distortion than compression. In addition to the attack and release times, there is another time parameter: "SmoothTime". The smoothing parameter will increase both the attack and release times, although the effect is significant only when its time is longer than the attack or release times. Generally the smoothing time should be kept at or shorter than the attack time.

This compressor provides two compressed segments. The signal below the lower threshold is not compressed. The compression ratio corresponding to the lower threshold sets the amount of compression for the lower compression segment. Above the upper threshold, the signal is compressed even further by the ratio corresponding to the upper threshold. You may use the upper segment as a limiter (infinite compression), or you may use the two compression segments to produce compression with a softer knee than you would get otherwise. For example, to make the algorithm a compressor and limiter, first choose the two thresholds. The limiter will of course have the higher threshold. Set the compression ratio for the higher threshold to "Inf:1". This gives you your limiter. Finally set the compression ratio for the lower threshold to the amount of compression that you want. Either pair of threshold and ratio parameters may be used for the upper compression segment—they are interchangeable. Above the upper threshold, the two compression ratios become additive. If both ratios are set to 3.0:1, then the compression of the upper segment will be 6.0:1. Another way to think of it is as two compressors wired in series (one after the other).

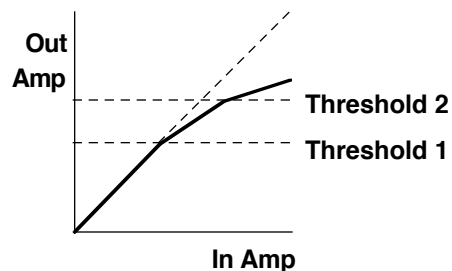

Two Segment Compression Characteristic

You have the choice of using the compressor configured as feed-forward or feedback. For feed-forward, set the FdbkComprs parameter to "Out"; for feedback compression, set it to "In". The feed-forward configuration uses the input signal as the side-chain source. The feedback compressor on the other hand uses the compressor output as the side-chain source. Feedback compression tends to be more subtle, but you cannot get an instant attack.

The expander attack/release times are similar, though there is only one expand segment. The expander works independently of the compressor. The expander cannot be configured for feedback (if it could, it would always shut itself off permanently). The signal delay path does affect the expander. The attack time is defined as the time for the expansion to turn off when the signal rises above the threshold. This time should be very short for most applications. The expander release time is the time for the signal to expand down after the signal drops below

threshold. The expander release time may be set quite long. An expander may be used to suppress background noise in the absence of signal, thus typical expander settings use a fast attack (to avoid losing real signal), slow release (to gradually fade out the noise), and the threshold set just above the noise level. You can set just how far to drop the noise with the expansion ratio.

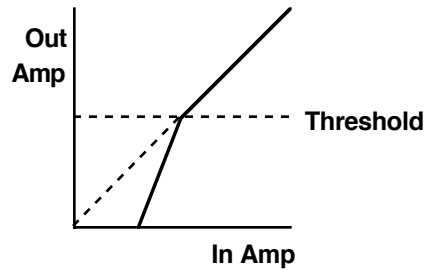

Expansion Transfer Characteristic

The signal being compressed/expanded may be delayed relative to the side chain processing. The delay allows the signal to start being compressed (or stop being expanded) just before an attack transient arrives. Since the side chain processing “knows” what the input signal is going to be before the main signal path does, it can tame down an attack transient by compressing the attack before it actually happens (or releasing the expander before the attack happens). This feature works whether the side chain is configured for feed-forward or feedback.

A meter is provided to display the amount of gain reduction that is applied to the signal as a result of compression and expansion.

The algorithm Comp/Exp + EQ differs from Compress/Expand in that the compressor and expander sections are followed by equalization filters. The output signal may be filtered with bass and treble shelving filters and a mid-range parametric filter.

Parameters:

PAGE 1

In/Out	In or Out	Out Gain	Off, -79.0 to 24.0 dB
FdbkComprs	In or Out		

PAGE 2

Comp Atk	0.0 to 228.0 ms	Exp Atk	0.0 to 228.0 ms
Comp Rel	0 to 3000 ms	Exp Rel	0 to 3000 ms
SmoothTime	0.0 to 228.0 ms		
Signal Dly	0.0 to 25.0 ms		

PAGE 3

Comp1Ratio	1.0:1 to 100.0:1, Inf:1	Exp Ratio	1:1.0 to 1:17.0
Comp1Thres	-79.0 to 0.0 dB	Exp Thres	-79.0 to 0.0 dB
Comp2Ratio	1.0:1 to 100.0:1, Inf:1	MakeUpGain	Off, -79.0 to 24.0 dB
Comp2Thres	-79.0 to 0.0 dB		
Reduction			
-dB 40 20 12 8 6 4 2 0			

PAGE 4 (Comp/Exp + EQ only)

Bass Gain	-79.0 to 24.0 dB	Treb Gain	-79.0 to 24.0 dB
Bass Freq	16 to 25088 Hz	Treb Freq	16 to 25088 Hz
Mid Gain	-79.0 to 24.0 dB		
Mid Freq	16 to 25088 Hz		
Mid Wid	0.010 to 5.000 oct		

- In/Out When set to “In” the compressor/expander is active; when set to “Out” the compressor/expander is bypassed.
- Out Gain Compressing the signal causes a reduction in signal level. To compensate, the output gain parameter may be used to increase the gain by as much as 24 dB. Note that the Out Gain parameter does not control the signal level when the algorithm is set to “Out”.
- FdbkComprs A switch to set whether the compressor side chain is configured for feed-forward (Out) or feedback (In). The expander is unaffected.
- Comp Atk The time for the compressor to start to cut in when there is an increase in signal level (attack) above the threshold.
- Comp Rel The time for the compressor to stop compressing when there is a reduction in signal level (release) from a signal level above the threshold.
- Exp Atk The time for the expander to increase the gain of the signal (turns off the expander) after the signal rises above threshold.
- Exp Rel The time for the expander to reduce the signal level when the signal drops below the threshold (turning on expansion).
- SmoothTime A lowpass filter in the control signal path. It is intended to smooth the output of the expander’s envelope detector. Smoothing will affect the attack or release times when the smoothing time is longer than one of the other times.
- Signal Dly The time in ms by which the input signal should be delayed with respect to compressor side chain processing (i.e. side chain pre-delay). This allows the compression to appear to take effect just before the signal actually rises.
- Comp1Ratio The compression ratio in effect above compression threshold #1 (Comp1Thres). High ratios are highly compressed; low ratios are moderately compressed.
- Comp1Thres One of two compression threshold levels. Threshold is expressed in dBFS (decibels relative to full scale) above which the signal begins to be compressed.
- Comp2Ratio The compression ratio in effect above compression threshold #2 (Comp2Thres). High ratios are highly compressed; low ratios are moderately compressed.
- Comp2Thres One of two compression threshold levels. Threshold is expressed in dBFS (decibels relative to full scale) above which the signal begins to be compressed.
- Exp Ratio The expansion ratio. High values (1:17 max) are highly expanded, low values (1:1 min) are moderately expanded.
- Exp Thres The expansion threshold level in dBFS (decibels relative to full scale) below which the signal begins to be expanded.
- MakeUpGain Provides an additional control of the output gain. The Out Gain and MakeUpGain controls are additive (in decibels) and together may provide a maximum of 24 dB boost to offset gain reduction due to compression or expansion.

Comp/Exp + EQ:

<u>Bass Gain</u>	The amount of boost or cut that the bass shelving filter should apply to the low frequency signals in dB. Every increase of 6 dB approximately doubles the amplitude of the signal. Positive values boost the bass signal below the specified frequency. Negative values cut the bass signal below the specified frequency.
<u>Bass Freq</u>	The center frequency of the bass shelving filter in intervals of one semitone.
<u>Treb Gain</u>	The amount of boost or cut that the treble shelving filter should apply to the high frequency signals in dB. Every increase of 6 dB approximately doubles the amplitude of the signal. Positive values boost the treble signal above the specified frequency. Negative values cut the treble signal above the specified frequency.
<u>Treb Freq</u>	The center frequency of the treble shelving filter in intervals of one semitone.
<u>Mid Gain</u>	The amount of boost or cut that the mid parametric filter should apply in dB. Every increase of 6 dB approximately doubles the amplitude of the signal. Positive values boost the signal at the specified frequency. Negative values cut the signal at the specified frequency.
<u>Mid Freq</u>	The center frequency of the mid parametric filter in intervals of one semitone. The boost or cut will be at a maximum at this frequency.
<u>Mid Wid</u>	The bandwidth of the mid parametric filter may be adjusted. You specify the bandwidth in octaves. Small values result in a very narrow filter response. Large values result in a very broad response.

FXAlg #956: Compress 3 Band

Stereo soft-knee 3-frequency band compression algorithm *Allocation Units: 4*

The 3-band compressor divides the input stereo signal into 3 frequency bands and runs each band through its own stereo soft-knee compressor. After compression, the bands are summed back together to produce the output. You may set the frequencies at which the bands are split.

The compressors reduce the signal level when the signal exceeds a threshold. The amount of compression is expressed as a ratio. The compression ratio is the inverse of the slope of the compressor input/output characteristic. The amount of compression is based on the sum of the magnitudes of the left and right channels. A compression ratio of 1:1 will have no effect on the signal. An infinite ratio, will compress all signal levels above the threshold level to the threshold level (zero slope). For ratios in between infinite and 1:1, increasing the input will increase the output, but by less than it would if there was no compression. The threshold is expressed as a decibel level relative to digital full-scale (dBFS) where 0 dBFS is digital full-scale and all other available values are negative.

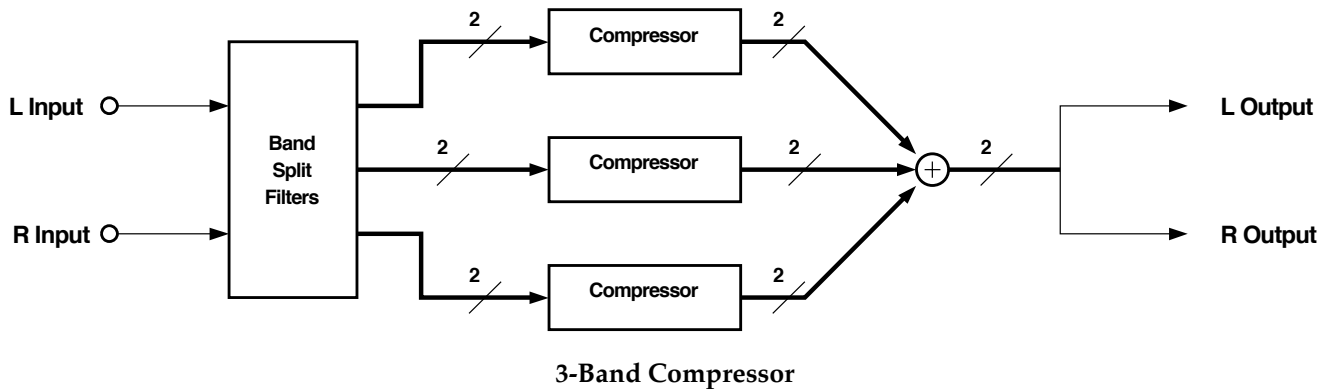

For details about the compression action, see the section in this book on FXAlg #950.

Parameters:

PAGE 1

In/Out	In or Out	Out Gain	Off, -79.0 to 24.0 dB
FdbkComprs	In or Out	Crossover1	16 to 25088 Hz
Signal Dly	0.0 to 25.0 ms	Crossover2	16 to 25088 Hz

PAGE 2

Atk Low	0.0 to 228.0 ms	Ratio Low	1.0:1 to 100.0:1, Inf:1
Rel Low	0 to 3000 ms	Thres Low	-79.0 to 24.0 dB
Smth Low	0.0 to 228.0 ms	MakeUp Low	Off, -79.0 to 24.0 dB
Low Band Reduction			
-dB 40 20 12 8 6 4 2 0			

PAGE 3

Atk Mid	0.0 to 228.0 ms	Ratio Mid	1.0:1 to 100.0:1, Inf:1
Rel Mid	0 to 3000 ms	Thres Mid	-79.0 to 24.0 dB
Smth Mid	0.0 to 228.0 ms	MakeUp Mid	Off, -79.0 to 24.0 dB
Mid Band Reduction			
-dB 40 20 12 8 6 4 2 0			

PAGE 4

Atk High	0.0 to 228.0 ms	Ratio High	1.0:1 to 100.0:1, Inf:1
Rel High	0 to 3000 ms	Thres High	-79.0 to 24.0 dB
Smth High	0.0 to 228.0 ms	MakeUpHigh	Off, -79.0 to 24.0 dB
High Band Reduction			
-dB 40 20 12 8 6 4 2 0			

<u>In/Out</u>	When set to “In” the compressor is active; when set to “Out” the compressor is bypassed.
<u>Out Gain</u>	Compressing the signal causes a reduction in signal level. To compensate, the output gain parameter may be used to increase the gain by as much as 24 dB. Note that the Out Gain parameter does not control the signal level when the algorithm is set to “Out”.
<u>FdbkComprs</u>	A switch to set whether the compressor side chain is configured for feed-forward (Out) or feedback (In).
<u>Signal Dly</u>	The time in ms by which the input signal should be delayed with respect to compressor side chain processing (i.e. side chain pre-delay). This allows the compression to appear to take effect just before the signal actually rises.
<u>CrossoverN</u>	The Crossover parameters (1 and 2) set the frequencies which divide the three compression frequency bands. The two parameters are interchangeable, so either may contain the higher frequency value.
<u>Atk Band</u>	(<i>Band</i> is Low, Mid or High) The time for the compressor to start to cut in when there is an increase in signal level (attack) above the threshold.
<u>Rel Band</u>	(<i>Band</i> is Low, Mid or High) The time for the compressor to stop compressing when there is a reduction in signal level (release) from a signal level above the threshold.
<u>Smth Band</u>	(<i>Band</i> is Low, Mid or High) A lowpass filter in the control signal path. It is intended to smooth the output of the expander’s envelope detector. Smoothing will affect the attack or release times when the smoothing time is longer than one of the other times.
<u>RatioBand</u>	(<i>Band</i> is Low, Mid or High) The compression ratio. High ratios are highly compressed; low ratios are moderately compressed.
<u>ThresBand</u>	(<i>Band</i> is Low, Mid or High) The threshold level in dBFS (decibels relative to full scale) above which the signal begins to be compressed.

FXAlg #957: Gate • FXAlg #958: Super Gate

Signal gate algorithms

Allocation Units: 1 for Gate; 2 for Super Gate

Gate and Super Gate do stand-alone gate processing and can be configured as a stereo or mono effects. As a stereo effect, the stereo signal gates itself based on its amplitude. As a mono effect, you can use one mono input signal to gate a second mono input signal (or one channel can gate itself). Separate output gain and panning for both channels is provided for improved mono processing flexibility.

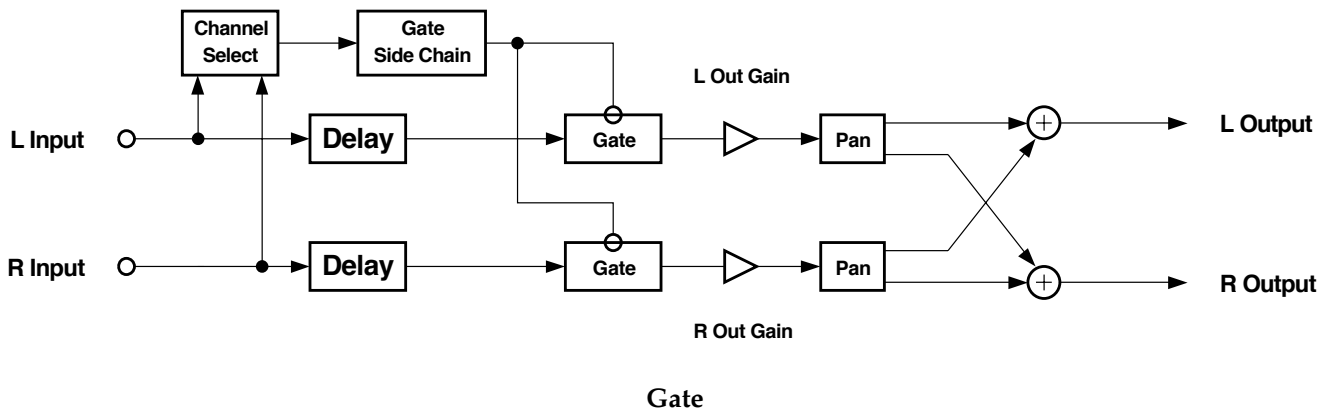

A gate behaves like an on off switch for a signal. One or both input channels is used to control whether the switch is on (gate is open) or off (gate is closed). The on/off control is called “side chain” processing. You select which of the two input channels or both is used for side chain processing. When you select both channels, the sum of the left and right input amplitudes is used. The gate is opened when the side chain amplitude rises above a level that you specify with the Threshold parameter.

Super Gate will behave differently depending on whether the Retrigger parameter is set to off or on.

If Retrigger is on, the gate will stay open for as long as the side chain signal is above the threshold. When the signal drops below the threshold, the gate will remain open for the time set with the Gate Time parameter. At the end of the Gate Time, the gate closes. When the signal rises above threshold, it opens again. What is happening is that the gate timer is being constantly retriggered while the signal is above threshold. You will typically use the gate with Retrigger on for percussive sounds. For the simpler Gate, there is no Retrigger parameter, and it is as if Retrigger is always on.

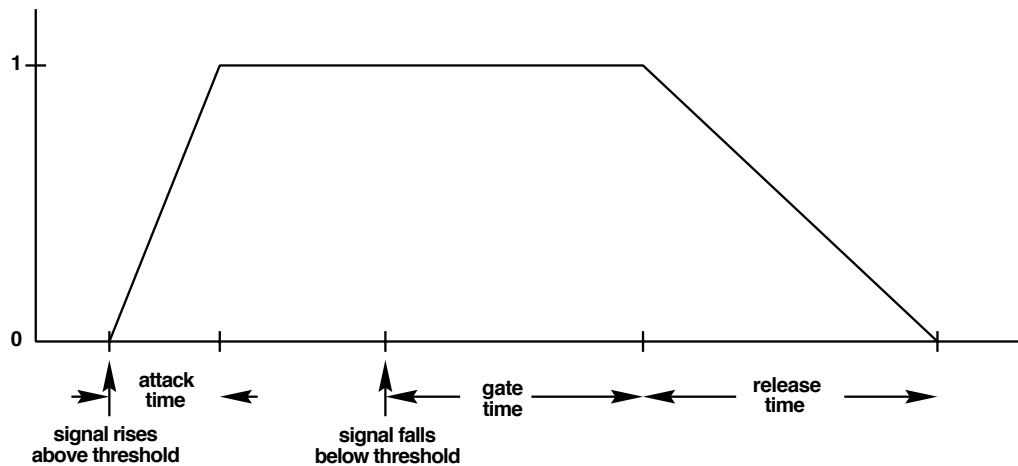

Signal envelope for Gate and Super Gate when Retrigger is "On"

If Retrigger is off (Super Gate only), then the gate will open when the side chain signal rises above threshold as before. The gate will then close as soon as the gate time has elapsed, whether or not the signal is still above threshold. The gate will not open again until the envelope of the side chain signal falls below the threshold and rises above threshold again. Since an envelope follower is used, you can control how fast the envelope follows the signal with the Env Time parameter. Retrigger set to off is useful for gating sustained sounds or where you need precise control of how long the gate should remain open.

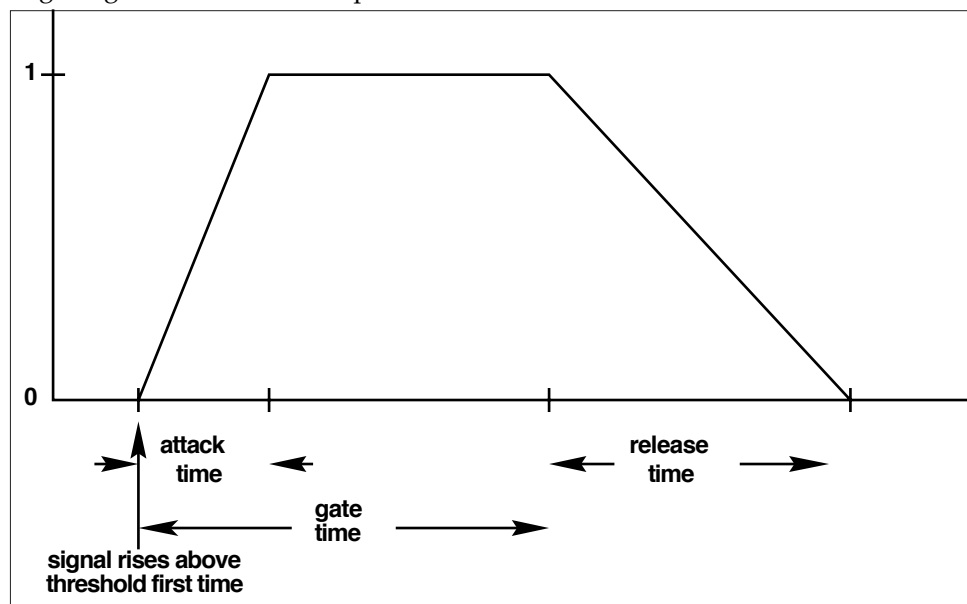

Super Gate signal envelope when Retrigger is "Off"

If Ducking is turned on, then the behavior of the gate is reversed. The gate is open while the side chain signal is below threshold, and it closes when the signal rises above threshold.

If the gate opened and closed instantaneously, you would hear a large digital click, like a big knife switch was being thrown. Obviously that's not a good idea, so Atk Time (attack) and Rel Time (release) parameters are used to set the times for the gate to open and close. More precisely, depending on whether Ducking is off or on, Atk Time sets how fast the gate opens or closes when the side chain signal rises above the threshold. The Rel Time sets how fast the

FXAlg #957: Gate · FXAlg #958: Super Gate

gate closes or opens after the gate timer has elapsed.

The Signal Dly parameter delays the signal being gated, but does not delay the side chain signal. By delaying the main signal relative to the side chain signal, you can open the gate just before the main signal rises above threshold. It's a little like being able to pick up the telephone before it rings!

For Super Gate (not the simpler Gate), filtering can be done on the side chain signal. There are controls for a bass shelf filter, a treble shelf filter and a parametric (mid) filter. By filtering the side chain, you can control the sensitivity of the gate to different frequencies. For example, you can have the gate open only if high frequencies are present— or only if low frequencies are present.

Parameters:

PAGE 1

In/Out	In or Out		
L Out Gain	Off, -79.0 to 24.0 dB	R Out Gain	Off, -79.0 to 24.0 dB
L Pan	-100 to 100%	R Pan	-100 to 100%
SC Input	(L+R)/2		

PAGE 2

Threshold	-79.0 to 24.0 dB	Gate Time	0 to 3000 ms
Ducking	On or Off	Atk Time	0.0 to 228.0 ms
Retrigger*	On or Off	Rel Time	0 to 3000 ms
Env Time*	0 to 3000 ms	Signal Dly	0.0 to 25.0 ms
Reduction			
-dB 60 40 * 16 * 8 4 0			

*Super Gate only

PAGE 3 - (Super Gate)

SCBassGain	-79.0 to 24.0 dB	SCTrebGain	-79.0 to 24.0 dB
SCBassFreq	16 to 25088 Hz	SCTrebFreq	16 to 25088 Hz
SCMidGain	-79.0 to 24.0 dB		
SCMidFreq	16 to 25088 Hz		
SCMidWidth	0.010 to 5.000 oct		

- In/Out When set to “In” the gate is active; when set to “Out” the gate is bypassed.
- L/R Out Gain The separate output signal levels in dB for the left and right channels. The output gains are calculated before the final output panning.
- L/R Pan Both of the gated signal channels can be panned between left and right prior to final output. This can be useful when the gate is used as a mono effect, and you don't want to hear one of the input channels, but you want your mono output panned to stereo. -100% is panned to the left, and 100% is panned to the right.
- SC Input The side chain input may be the amplitude of the left L input channel, the right R input channel, or the sum of the amplitudes of left and right (L+R)/2. You can gate a stereo signal with itself by using the sum, a mono signal with itself, or you can gate a mono signal using a second mono signal as the side chain.

<u>Threshold</u>	The signal level in dB required to open the gate (or close the gate if Ducking is on).
<u>Ducking</u>	When set to “Off”, the gate opens when the signal rises above threshold and closes when the gate time expires. When set to “On”, the gate closes when the signal rises above threshold and opens when the gate time expires.
<u>Retrigger</u>	If Retrigger is “On”, the gate timer is constantly restarted (retriggered) as long as the side chain signal is above the threshold. The gate then remains open (assuming Ducking is “Off”) until the signal falls below the threshold and the gate timer has elapsed. If Retrigger is “Off”, then the gate timer starts at the moment the signal rises above the threshold and the gate closes after the timer elapses, whether or not the signal is still above threshold. With Retrigger off, use the Env Time to control how fast the side chain signal envelope drops below the threshold. With Retrigger set to off, the side chain envelope must fall below threshold before the gate can open again. [Super Gate only]
<u>Env Time</u>	Envelope time is for use when Retrigger is set to “Off”. The envelope time controls the time for the side chain signal envelope to drop below the threshold. At short times, the gate can reopen rapidly after it has closed, and you may find the gate opening unexpectedly due to an amplitude modulation of the side chain signal. For long times, the gate will remain closed until the envelope has a chance to fall, and you may miss gating events.
<u>Gate Time</u>	The time in seconds that the gate will stay fully on after the signal envelope rises above threshold. The gate timer is started or restarted whenever the signal envelope rises above threshold. If Retrigger is On, the gate timer is continually reset while the side chain signal is above the threshold.
<u>Atk Time</u>	The time for the gate to ramp from closed to open (reverse if Ducking is on) after the signal rises above threshold.
<u>Rel Time</u>	The time for the gate to ramp from open to closed (reverse if Ducking is on) after the gate timer has elapsed.
<u>Signal Dly</u>	The delay in milliseconds (ms) of the signal to be gated relative to the side chain signal. By delaying the main signal, the gate can be opened before the main signal rises above the gating threshold.

Super Gate:

<u>SCBassGain</u>	The amount of boost or cut that the side chain bass shelving filter should apply to the low frequency signals in dB. Every increase of 6 dB approximately doubles the amplitude of the signal. Positive values boost the bass signal below the specified frequency. Negative values cut the bass signal below the specified frequency.
<u>SCBassFreq</u>	The center frequency of the side chain bass shelving filters in intervals of one semitone.
<u>SCTrebleGain</u>	The amount of boost or cut that the side chain treble shelving filter should apply to the high frequency signals in dB. Every increase of 6 dB approximately doubles the amplitude of the signal. Positive values boost the treble signal above the specified frequency. Negative values cut the treble signal above the specified frequency.
<u>SCTrebleFreq</u>	The center frequency of the side chain treble shelving filters in intervals of one semitone.
<u>SCMidGain</u>	The amount of boost or cut that the side chain parametric mid filter should apply in dB to the specified frequency band. Every increase of 6 dB approximately doubles the amplitude of the signal. Positive values boost the signal at the specified frequency. Negative values cut the signal at the specified frequency.
<u>SCMidFreq</u>	The center frequency of the side chain parametric mid filter in intervals of one semitone. The boost or cut will be at a maximum at this frequency.
<u>SCMidWidth</u>	The bandwidth of the side chain parametric mid filter may be adjusted. You specify the bandwidth in octaves. Small values result in a very narrow filter response. Large values result in a very broad response.

FXAlg #959: 2 Band Enhancer

2-band spectral modifier *Allocation Units: 1*

The 2 Band Enhancer modifies the spectral content of the input signal primarily by brightening signals with little or no high frequency content, and boosting pre-existing bass energy. First, the input is non-destructively split into two frequency bands using 6 dB/oct hipass and lopass filters. The hipassed band is processed to add additional high frequency content by using a nonlinear transfer function in combination with a high shelving filter. Each band can then be separately delayed to sample accuracy and mixed back together in varying amounts. One sample of delay is approximately equivalent to 20 microseconds, or 180 degrees of phase shift at 24 kHz. Using what we know about psychoacoustics, phase shifting or delaying certain frequency bands relative to others can have useful effects without adding any gain. In this algorithm, delaying the lopass signal relative to the hipass signal brings out the high-frequency transient of the input signal giving it more definition. Conversely, delaying the hipass signal relative to the lopass signal brings out the low-frequency transient information which can provide punch.

The transfer applied to the hipass signal can be used to generate additional high-frequency content when set to a non-zero value. As the value is scrolled away from 0, harmonic content is added in increasing amounts to brighten the signal. In addition to adding harmonics, positive values impose a dynamically compressed quality, while negative values sound dynamically expanded. This type of compression can bring out frequencies in a particular band even more. The expanding quality is particularly useful when trying to restore transient information.

Parameters:

PAGE 1

In/Out	In or Out	Out Gain	Off, -79.0 to 24.0 dB
CrossOver	17 to 25088 Hz		

PAGE 2

Hi Drive	Off, -79.0 to 24.0 dB		
Hi Xfer	-100 to 100%		
Hi Shelf F	16 to 25088 Hz		
Hi Shelf G	-96 to 24 dB		
Hi Delay	0 to 500 samp	Lo Delay	0 to 500 samp
Hi Mix	Off, -79.0 to 24.0 dB	Lo Mix	Off, -79.0 to 24.0 dB

<u>In/Out</u>	When set to "In" the effect is active; when set to "Out" the effect is bypassed.
<u>Out Gain</u>	The overall gain or amplitude at the output of the effect.
<u>CrossOver</u>	Adjusts the -6dB crossover point at which the input signal will be divided into the hipass band and a lopass bands.
<u>Hi Drive</u>	Adjusts the gain into the transfer function. The affect of the transfer can be intensified or reduced by respectively increasing or decreasing this value.
<u>Hi Xfer</u>	The intensity of the transfer function.
<u>Hi Shelf F</u>	The frequency of where the high shelving filter starts to boost or attenuate.

<u>Hi Shelf G</u>	The boost or cut of the high shelving filter.
<u>Hi Delay</u>	Adjusts the number of samples the hipass signal is delayed.
<u>Hi Mix</u>	Adjusts the output gain of the hipass signal.
<u>Lo Delay</u>	Adjusts the number of samples the lopass signal is delayed.
<u>Lo Mix</u>	Adjusts the output gain of the lopass signal.

FXAlg #960: 3 Band Enhancer

3-band spectral modifier

Allocation Units: 2

The 3 Band Enhancer modifies the spectral content of the input signal by boosting existing spectral content, or stimulating new content. First, the input is non-destructively split into 3 frequency bands using 6 dB/oct hipass and lopass filters. The high and mid bands are separately processed to add additional high-frequency content by using two nonlinear transfer functions. The low band is processed by a single nonlinear transfer to enhance low-frequency energy. Each band can also be separately delayed to sample accuracy and mixed back together in varying amounts. One sample of delay is approximately equivalent to 20 microseconds, or 180 degrees of phase shift at 24 kHz sampling rate. Using what we know about psychoacoustics, phase shifting or delaying certain frequency bands relative to others can have useful effects without adding any gain. In this algorithm, delaying the lower bands relative to higher bands brings out the high-frequency transient of the input signal giving it more definition. Conversely, delaying the higher bands relative to the lower bands brings out the low-frequency transient information which can provide punch.

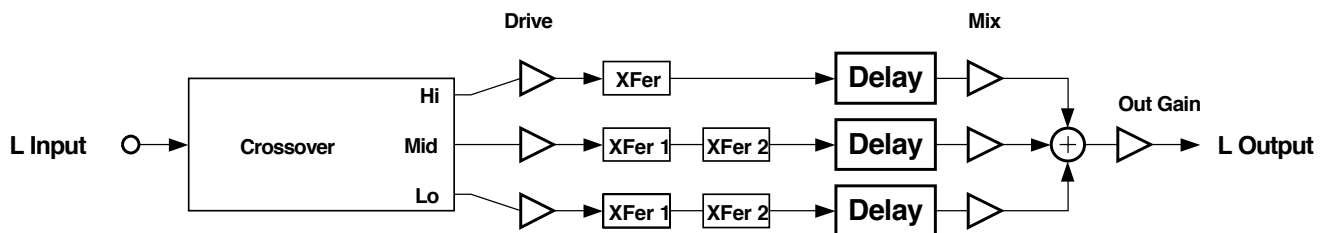

One channel of 3 Band Enhancer

The nonlinear transfers applied to the high and mid bands can be used to generate additional high- and mid-frequency content when Xfer1 and Xfer2 are set to non-zero values. As the value is scrolled away from 0, harmonic content is added in increasing amounts. In addition, setting both positive or negative will respectively impose a dynamically compressed or expanded quality. This type of compression can bring out frequencies in a particular band even more. The expanding quality is useful when trying to restore transient information. More complex dynamic control can be obtained by setting these independent of each other. Setting one positive and the other negative can even reduce the noise floor in some applications.

The low band has a nonlinear transfer that requires only one parameter. Its effect is controlled similarly.

Parameters:

PAGE 1

In/Out	In or Out	Out Gain	Off, -79.0 to 24.0 dB
CrossOver1	17 to 25088 Hz		
CrossOver2	17 to 25088 Hz		

PAGE 2

Lo Enable	On or Off	Mid Enable	On or Off
Lo Drive	Off, -79.0 to 24.0 dB	Mid Drive	Off, -79.0 to 24.0 dB
Lo Xfer	-100 to 100%	Mid Xfer1	-100 to 100%
		Mid Xfer2	-100 to 100%
Lo Delay	0 to 1000 samp	Mid Delay	0 to 500 samp
Lo Mix	Off, -79.0 to 24.0 dB	Mid Mix	Off, -79.0 to 24.0 dB

PAGE 3

Hi Enable	On or Off		
Hi Drive	Off, -79.0 to 24.0 dB		
Hi Xfer1	-100 to 100%		
Hi Xfer2	-100 to 100%		
Hi Delay	0 to 500 samp		
Hi Mix	Off, -79.0 to 24.0 dB		

In/Out

When set to "In" the effect is active; when set to "Out" the effect is bypassed.

Out Gain

The overall gain or amplitude at the output of the effect.

CrossOver1

Adjusts one of the -6dB crossover points at which the input signal will be divided into the high, mid and low bands.

CrossOver2

Adjusts the other -6dB crossover points at which the input signal will be divided into the high, mid and low bands.

Lo Enable, Mid Enable, Hi Enable Turns processing for each band on or off. Turning each of the 3 bands off results in a dry output signal.

Lo Drive, Mid Drive, Hi Drive Adjusts the input into each transfer. Increasing the drive will increase the effects.

Lo Xfer, Mid Xfer1, Mid Xfer2, Hi Xfer1, Hi Xfer2 Adjusts the intensity of the transfer curves.

Lo Delay, Mid Delay, Hi Delay Adjusts the number of samples the each signal is delayed.

Lo Mix, Mid Mix, Hi Mix Adjusts the output gain of each band.

FXAlgs #961/962: Tremolo and Tremolo BPM

A stereo tremolo or auto-balance effect.

Allocation Units: 1

Tremolo and Tremolo BPM are 1-PAU stereo tremolo effects. In the classical sense, a tremolo is the rapid repetition of a single note created by an instrument. Early music synthesists imitated this by using an LFO to modulate the amplitude of a tone. This is the same concept as amplitude modulation, except that a tremolo usually implies that the modulation rate is much slower.

Tremolo and Tremolo BPM provide six different LFO shapes, as follows:

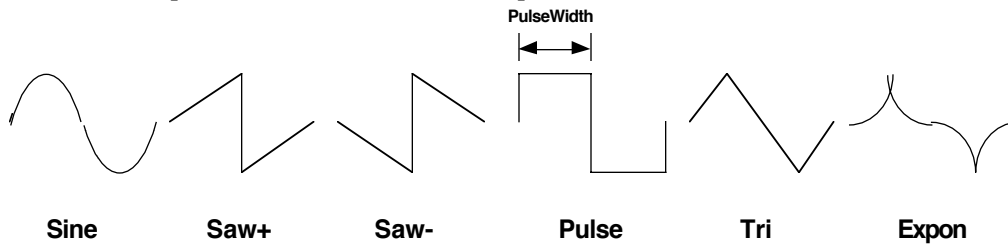

LFO Shapes available for Tremolo and Tremolo BPM

An additional shape modifier is "50% Weight". This bends the LFO shape up or down relative to its -6dB point. At 0dB, there is no change to the LFO shape. Positive values will bend the LFO up towards unity, while negative values will bend it down towards full attenuation.

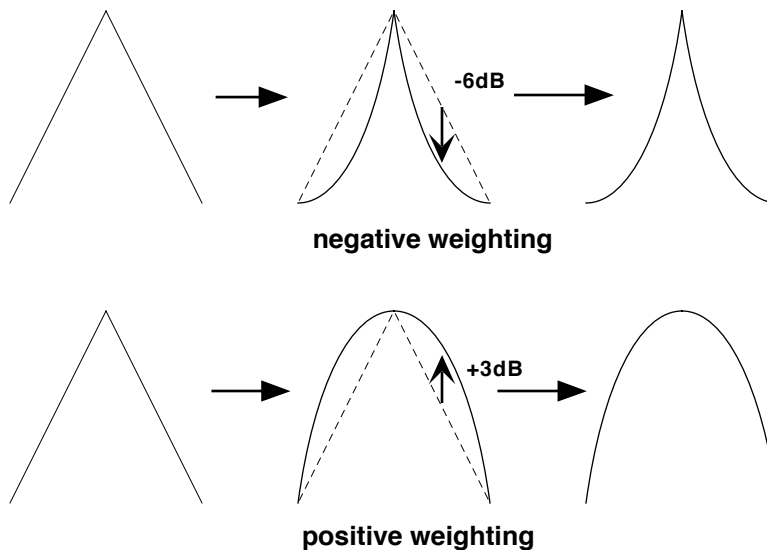

Action of the "50% Weight" parameter

Other features include "L/R Phase", which flips the LFO phase of the left channel for auto-balancing applications, and LFO metering, which can be viewed on the bottom of the PARAM2 page.

Tremolo also includes an LFO rate scale for AM synthesis. Tremolo BPM provides tempo-based LFO syncing including system syncing.

Parameters (Tremolo):

PAGE 1

In/Out	In or Out	Out Gain	Off, -79.0 to 24.0 dB
--------	-----------	----------	-----------------------

PAGE 2

LFO Rate	0 to 10.00 Hz	LFO Shape	Tri
Rate Scale	1 to 25088 x	PulseWidth	0 to 100%
Depth	0 to 100%	50% Weight	-6 to 3 dB
		L/R Phase	In or Out
	A		
	0%	50%	100%

Parameters (Tremolo BPM):

PAGE 1

In/Out	In or Out	Out Gain	Off, -79.0 to 24.0 dB
		Tempo	System, 0 to 255 BPM

PAGE 2

LFO Rate	0 to 12.00 x	LFO Shape	Tri
LFO Phase	0.0 to 360.0 deg	PulseWidth	0 to 100%
Depth	0 to 100%	50% Weight	-6 to 3 dB
		L/R Phase	In or Out
	A		
	0%	50%	100%

<u>In/Out</u>	When set to "In" the effect is active; when set to "Out" the effect is bypassed.
<u>Out Gain</u>	The overall gain or amplitude at the output of the effect.
<u>Tempo</u> (Tremolo BPM)	Basis for the rate of the LFO, as referenced to a musical tempo in BPM (beats per minute). When this parameter is set to "System", the tempo is locked to the internal sequencer tempo or to incoming MIDI clocks. When it is set to "System", sources (FUNs, LFOs, ASRs etc.) will have no effect on the Tempo parameter.
<u>LFO Rate</u> (Tremolo)	The speed of the tremolo LFO in cycles per second.
<u>LFO Rate</u> (Tremolo BPM)	The number of LFO cycles in one beat relative to the selected Tempo. For example, 1.00x means the LFO repeats once per beat; 2.00x twice per beat; etc...
<u>Rate Scale</u> (Tremolo)	This multiplies the speed of the LFO rate into the audio range. When above 19x, the values increment in semitone steps. These steps are accurate when LFO Rate is set to 1.00 Hz.
<u>LFO Phase</u> (Tremolo BPM)	This parameter shifts the phase of the tremolo LFO relative to an internal beat reference. It is most useful when Tempo is set to "System" and LFO Phase controls the phase of the LFO relative to MIDI clock.
<u>Depth</u>	This controls the amount of attenuation applied when the LFO is at its deepest excursion point.
<u>LFO Shape</u>	The waveform type for the LFO. Choices are Sine, Saw+, Saw-, Pulse, Tri, and Expon.

FXAlgs #961/962: Tremolo and Tremolo BPM

<u>PulseWidth</u>	When the LFO Shape is set to Pulse, this parameter sets the pulse width as a percentage of the waveform period. The pulse is a square wave when the width is set to 50%. This parameter is active only when the Pulse waveform is selected.
<u>50% Weight</u>	The relative amount of attenuation added when the LFO is at the -6dB point. This causes the LFO shape to bow up or down depending on whether this parameter is set positive or negative.
<u>L/R Phase</u>	LFO phase relationship of the left channel. Flipping the left channel's LFO out of phase causes the effect to become an auto-balancer.

FXAlg #963: AutoPanner

A stereo auto-panner

Allocation Units: 1

"AutoPanner" is a 1-PAU stereo auto pan effect. The process of panning a stereo image consists of shrinking the image width of the input program then cyclically moving this smaller image from side to side while maintaining relative distances between program point sources. This effect provides six different LFO shapes (see the previous section of this book, FXAlgs #961-962), variable center attenuation, and a rate scaler that scales LFO rate into the audible range for a new flavor of amplitude modulation effects.

Final image placement can be monitored on the lower right of the PARAM2 page. The top meter labeled "L" shows the left edge of the image while the second meter labeled "R" shows the right edge. The entire image will fall between these two marks.

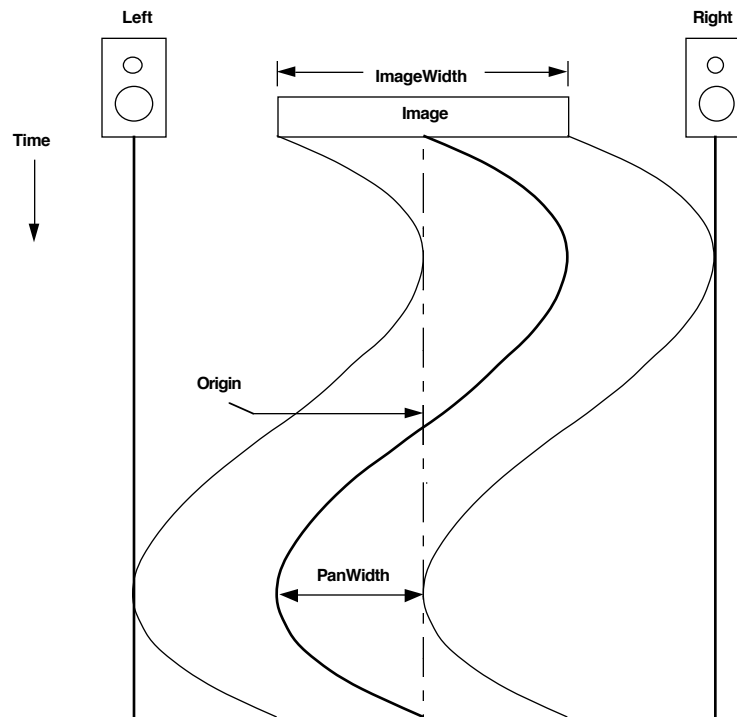

Concept of stereo autopanning with ImageWidth set to 50%, LFO Shape set to Sine, Origin set to 0%, and PanWidth set to 100%

Parameters:

PAGE 1

In/Out	In or Out	Out Gain	Off, -79.0 to 24.0 dB
--------	-----------	----------	-----------------------

PAGE 2

LFO Rate	0 to 10.00 Hz	LFO Shape	Tri
Rate Scale	1 to 25088 x	PulseWidth	0 to 100%
Origin	-100 to 100%		
PanWidth	0 to 100%	L	
ImageWidth	0 to 100%	R	
CentrAtten	-12 to 0 dB	L	C R

- In/Out When set to "In" the auto-panner is active; when set to "Out" auto-panner is bypassed.
- Out Gain The overall gain or amplitude at the output of the effect.
- LFO Rate The speed of the panning motion.
- Rate Scale This multiplies the speed of the LFO rate into the audio range. When above 19x, the values increment in semitone steps. These steps are musically accurate when the LFO Rate is set to 1.00 Hz.
- Origin The axis for the panning motion. At 0%, panning excursion is centered between the listening speakers. Positive values shift the axis to the right, while negative values shift it to the left. At -100% or +100%, there is no room for panning excursion.
- Pan Width The amount of auto pan excursion. This value represents the percentage of total panning motion available after Origin and ImageWidth are set.
- ImageWidth The width of the original input program material before it is auto panned. At 0%, the input image is shrunk to a single point source allowing maximum panning excursion. At 100%, the original width is maintained leaving no room for panning excursion.
- CentrAtten Amount the signal level is dropped as it is panned through the center of the listening stereo speaker array. For the smoothest tracking, a widely accepted subjective reference is -3dB. Values above -3dB will cause somewhat of a bump in level as an image passes through the center. Values below -3dB will cause a dip in level at the center.
- LFO Shape The waveform type for the LFO. Choices are Sine, Saw+, Saw-, Pulse, Tri, and Expon.
- PulseWidth When the LFO Shape is set to Pulse, this parameter sets the pulse width as a percentage of the waveform period. The pulse is a square wave when the width is set to 50%. This parameter is active only when the Pulse waveform is selected.

FXAlg #964: Dual AutoPanner

A dual mono auto-panner

Allocation Units: 2

"Dual AutoPanner" is a 2-PAU dual mono auto-pan effect. Left and right inputs are treated as two mono signals which can each be independently auto-panned. Parameters beginning with "L" control the left input channel, and parameters beginning with "R" control the right input channel. Autopanning a mono signal consists of choosing an axis offset, or Origin, as the center of LFO excursion, then adjusting the desired excursion amount, or PanWidth. Note that the PanWidth parameter is a percentage of the available excursion space after Origin is adjusted. If Origin is set to full left (-100%) or full right (100%) then there will be no room for LFO excursion. Control of six different LFO shapes (see the section of this book on FXAlgs #961-962), variable center attenuation, and a rate scaler that scales LFO rate into the audible range for a new flavor of amplitude modulation effects are also provided for each channel.

Final image placement can be seen on the bottom right of the PARAM2 and PARAM3 pages respectively for left and right input channels. The moving mark represents the location of each channel within the stereo field.

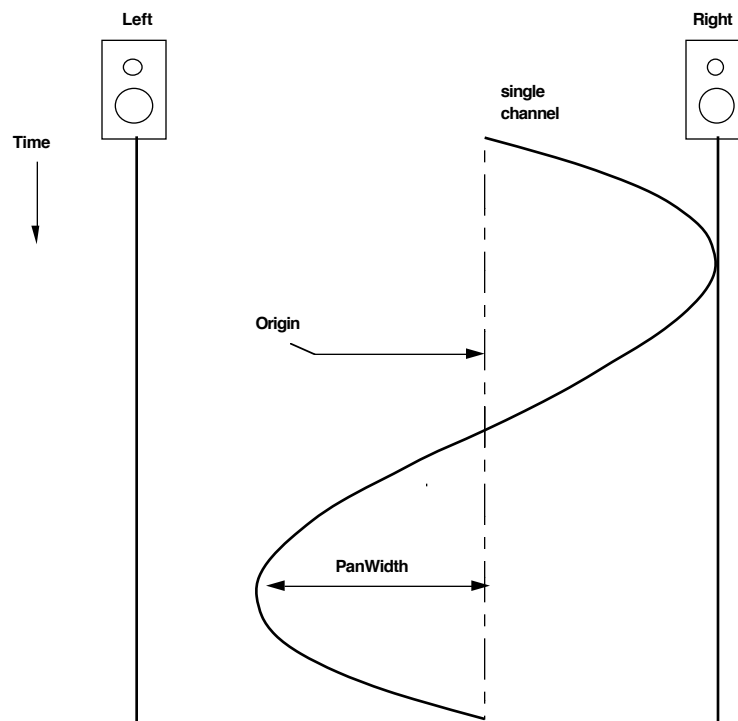

Concept of mono auto-panning with LFO Shape set to Sine, Origin set to 15%, and PanWidth set to 100%

Parameters:

PAGE 1

L In/Out	In or Out	R In/Out	In or Out
L Out Gain	Off, -79.0 to 24.0 dB	R Out Gain	Off, -79.0 to 24.0 dB

PAGE 2

L LFO Rate	0 to 10.00 Hz	L LFO Shape	Tri
L RateScal	1 to 25088 x	L PlseWdth	0 to 100%
L Origin	-100 to 100%		
L PanWidth	0 to 100%		
L CentrAtt	0 to 100%	L	
		L	C R

PAGE 3

R LFO Rate	0 to 10.00 Hz	R LFO Shape	Tri
R RateScal	1 to 25088 x	R PlseWdth	0 to 100%
R Origin	-100 to 100%		
R PanWidth	0 to 100%		
R CentrAtt	0 to 100%	R	
		L	C R

- In/Out When set to "In" the auto-panner is active; when set to "Out" auto-panner is bypassed.
- Out Gain The overall gain or amplitude at the output of the effect.
- LFO Rate The speed of the panning motion.
- Origin The axis for the panning motion. At 0%, panning excursion will be centered at the center of the listening speakers. Positive values shift the axis to the right, while negative values shift it to the left. At -100% or +100%, there is no room for panning excursion.
- Pan Width The amount of auto pan excursion. This value represents the percentage of total panning motion available after Origin is set.
- CentrAtten Amount the signal level is dropped as it is panned through the center of the listening stereo speaker array. For the smoothest tracking, a widely accepted subjective reference is -3dB. Values above -3dB will cause somewhat of a bump in level as an image passes through the center. Values below -3dB will cause a dip in level at the center.
- LFO Shape The waveform type for the LFO. Choices are Sine, Saw+, Saw-, Pulse, Tri, and Expon.
- PulseWidth When the LFO Shape is set to Pulse, this parameter sets the pulse width as a percentage of the waveform period. The pulse is a square wave when the width is set to 50%. This parameter is active only when the Pulse waveform is selected.

FXAlg #965: SRS

Licensed “Sound Retrieval System®” or SRS™ effect *Allocation Units: 1*

The SRS™ algorithm has been licensed from SRS Labs, Inc. The following is from an SRS Labs press release:

SRS, the Sound Retrieval System, is based on the human hearing system. It produces a fully immersive, three-dimensional sound image from any audio source with two or more standard stereo speakers. Whether the signal is mono, stereo, surround sound or encoded with any other audio enhancement technology, SRS expands the material and creates a realistic, panoramic sound experience with no “sweet spot” or centered listening position. SRS is single-ended, requiring no encoding or decoding, and uses no artificial signal manipulation such as time delay or phase shift to produce its natural, true-to-life sound image.

The four SRS parameters control the ambience of the image, and may have different optimal settings depending on the amount of stereo content in the inputs. To match the optimal settings specified by SRS Labs, the bass and treble gains should be set to 0 dB. This algorithm will have no effect on mono signals.

Parameters:

PAGE 1

In/Out	In or Out	Out Gain	Off, -79.0 to 24.0 dB
Center	Off, -79.0 to 24.0 dB	Bass Gain	-79.0 to 24.0 dB
Space	Off, -79.0 to 24.0 dB	Treb Gain	-79.0 to 24.0 dB

<u>In/Out</u>	When set to “In” the effect is active; when set to “Out” the effect is bypassed.
<u>Out Gain</u>	The overall gain or amplitude at the output of the effect. Out Gain is not applied to the signal when the effect is bypassed.
<u>Center</u>	The amount of “center channel” can be varied with this control.
<u>Space</u>	The width of the image is controlled with this parameter.
<u>Bass Gain</u>	The amount of ambience added to the Bass frequencies in the signals. A setting of 0 dB gives a best match to the optimizations of SRS Labs.
<u>Treb Gain</u>	The amount of ambience added to the Treble frequencies in the signal. A setting of 0 dB gives a best match to the optimizations of SRS Labs.

FXAlg #966: Stereo Image

Stereo enhancement with stereo channel correlation metering

Allocation Units: 1

Stereo Image is a stereo enhancement algorithm with metering for stereo channel correlation. The stereo enhancement performs simple manipulations of the sum and difference of the left and right input channels to allow widening of the stereo field and increased sound field envelopment. After manipulating sum and difference signals, the signals are recombined (a sum and difference of the sum and difference) to produce final left and right output.

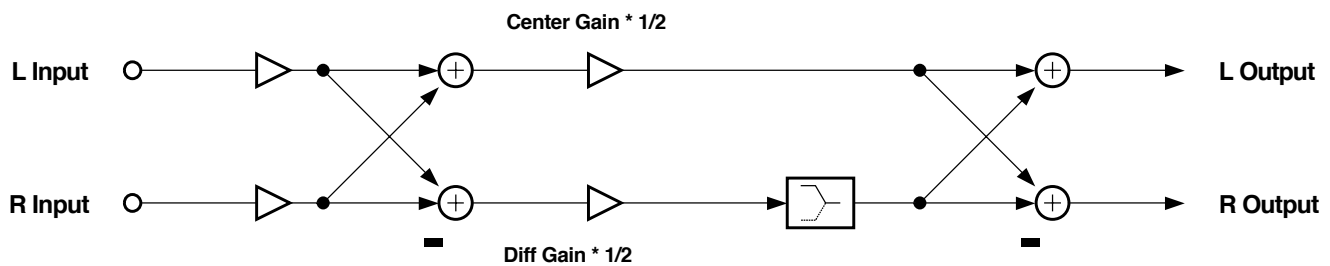

Block diagram of Stereo Image algorithm

The sum of left and right channels represents the mono or center mix of your stereo signal. The difference of left and right channels contains the part of the signal that contains stereo spatial information. The Stereo Image algorithm has controls to change the relative amounts of sum (or center) versus difference signals. By increasing the difference signal, you can broaden the stereo image. Be warned, though, that too much difference signal will make your stereo image sound “phasey”. With phasey stereo, acoustic images become difficult to localize and can sound like they are coming from all around you or from within your head.

A bass shelf filter on the difference signal is also provided. By boosting only the low frequencies of the difference signal, you can greatly improve your sense of stereo envelopment without destroying your stereo sound field. Envelopment is the feeling of being surrounded by your acoustic environment. Localized stereo images still come from between your stereo loudspeakers, but there is an increased sense of being wrapped in the sound field.

The Stereo Image algorithm contains a stereo correlation meter. The stereo correlation meter tells you how alike or how different your output stereo channels are from each other. When the meter is at 100% correlation, then your signal is essentially mono. At 0% correlation, your left and right channels are the same, but polarity-inverted (there is only difference signal). The correlation meter can give you an indication of how well a recording will mix to mono. The meter follows RMS signal levels (root-mean-square) and the RMS Settle parameter controls how responsive the meter is to changing signals. The ‘M’ part of RMS is “mean” or average of the squared signal. Since a mean over all time is neither practical or useful, we must calculate the mean over shorter periods of time. If the time is too short we are simply following the signal wave form, which is not helpful either, since the meter would constantly bounce around. The RMS Settle parameter provides a range of useful time scales.

See also the Stereo Analyze algorithm (FXAlg #999) which allows you to experiment directly with sum and difference signals.

Parameters:

PAGE 1

L In Gain	Off, -79.0 to 24.0 dB	R In Gain	Off, -79.0 to 24.0 dB
CenterGain	Off, -79.0 to 24.0 dB	Diff Gain	Off, -79.0 to 24.0 dB
L/R Delay	-500.0 to 500.0 samp	RMS Settle	0.0 to 300.0 dB/s

PAGE 2

DiffBassG	-79.0 to 24.0 dB		
DiffBassF	16 to 25088 Hz		
Stereo Correlation			
100 75 50 25 0%			

<u>L In Gain</u>	The input gain of the left channel in decibels (dB).
<u>R In Gain</u>	The input gain of the right channel in decibels (dB).
<u>CenterGain</u>	The level of the sum of left and right channels in decibels (dB). The summed stereo signal represents the mono or center mix.
<u>Diff Gain</u>	The level of the difference of left and right channels in decibels (dB). The difference signal contains the spatial component of the stereo signal.
<u>L/R Delay</u>	If this parameter is positive, the left signal is delayed by the indicated amount. If it is negative, the right channel is delayed. You can use this parameter to try to improve cancellation of the difference signal if you suspect one channel is delayed with respect to the other.
<u>RMS Settle</u>	Controls how fast the RMS meters can rise or fall with changing signal levels.
<u>DiffBassG</u>	By boosting the low frequency components of the difference signal you can increase the sense of acoustic envelopment, the sense of being surrounded by an acoustic space. DiffBassG is the gain parameter of a bass-shelf filter on the difference signal. DiffBassG sets how many decibels (dB) to boost or cut the low frequencies.
<u>DiffBassF</u>	The transition frequency in Hertz (Hz) of the difference signal bass-shelf filter is set by DiffBassF.

FXAlg #967: Mono -> Stereo

Stereo simulation from a mono input signal

Allocation Units: 1

Mono -> Stereo is an algorithm which creates a stereo signal from a mono input signal. The algorithm works by combining a number of band-splitting, panning and delay tricks. The In Select parameter lets you choose the left or right channel for the mono input, or you may choose to sum the left and right inputs.

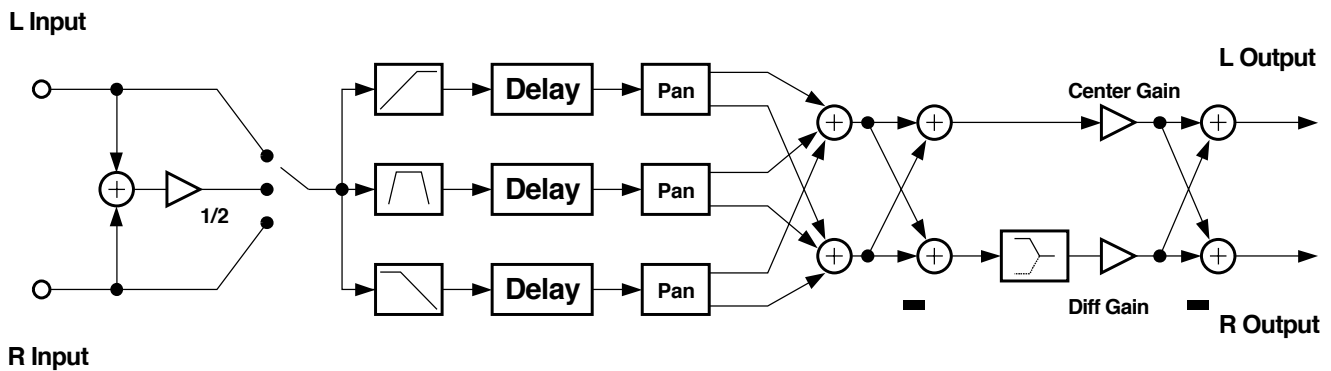

Block diagram of Mono -> Stereo effect.

The mono input signal is split into three frequency bands (Low, Mid, and High). The frequencies at which the bands get split are set with the Crossover parameters. Each band can then be delayed and panned to some position within the stereo field.

The final step manipulates the sum and difference signals of the pseudo-stereo signal created by recombining the split frequency bands. The sum of left and right channels represents the mono or center mix of your stereo signal. The difference of left and right channels contains the part of the signal that contains stereo spatial information. The Stereo Image algorithm has controls to change the relative amounts of sum (or center) versus difference signals. By increasing the difference signal, you can broaden the stereo image. Be warned, though, that too much difference signal will make your stereo image sound “phasey”. With phasey stereo, acoustic images become difficult to localize and can sound like they are coming from all around you or from within your head.

A bass shelf filter on the difference signal is also provided. By boosting only the low frequencies of the difference signal, you can greatly improve your sense of stereo envelopment without destroying your stereo sound field. Envelopment is the feeling of being surrounded by your acoustic environment. Localized stereo images still come from between your stereo loudspeakers, but there is an increased sense of being wrapped in the sound field.

Parameters:

PAGE 1

In/Out	In or Out	Out Gain	Off, -79.0 to 24.0 dB
CenterGain	Off, -79.0 to 24.0 dB	Diff Gain	Off, -79.0 to 24.0 dB
In Select	L, R, or (L+R)/2	DiffBassG	-79.0 to 24.0 dB
		DiffBassF	16 to 25088 Hz

PAGE 2

Crossover1	16 to 25088 Hz		
Crossover2	16 to 25088 Hz		
Pan High	-100 to 100%	Delay High	0.0 to 1000.0 ms
Pan Mid	-100 to 100%	Delay Mid	0.0 to 1000.0 ms
Pan Low	-100 to 100%	Delay Low	0.0 to 1000.0 ms

<u>In/Out</u>	The algorithm is functioning when In/Out is set to "In". If set to "Out, whatever is on the input channels gets passed to the output unaltered.
<u>Out Gain</u>	The output gain of the pseudo-stereo signal in decibels (dB).
<u>CenterGain</u>	The level of the sum of the intermediate left and right stereo channels in decibels (dB). The summed stereo signal represents the mono or center mix.
<u>Diff Gain</u>	The level of the difference of the intermediate left and right stereo channels in decibels (dB). The difference signal contains the spatial component of the stereo signal.
<u>In Select</u>	The input signal may come from the left L or right R input channel, or the left and right channels may be summed to obtain the mono signal $(L+R)/2$. You should set this parameter to match your Studio configuration.
<u>DiffBassG</u>	By boosting the low frequency components of the difference signal of the intermediate stereo result, you can increase the sense of acoustic envelopment, the sense of being surrounded by an acoustic space. DiffBassG is the gain parameter of a bass-shelf filter on the difference signal. DiffBassG sets how many decibels (dB) to boost or cut the low frequencies.
<u>DiffBassF</u>	The transition frequency in Hertz (Hz) of the difference signal bass-shelf filter is set by DiffBassF.
<u>CrossoverN</u>	The two Crossover parameters set the frequencies at which the band-split filters split the mono signal into three bands. The two parameters are interchangeable: either may have a higher frequency than the other.
<u>Pan Band</u>	There are three pan parameters: one each for Low, Mid, and High frequency bands. The panning of each band is separately controllable. -100% is fully left and 100% is fully right.
<u>Delay Band</u>	There are three delay parameters: one each for Low, Mid, and High frequency bands. The delays are set in milliseconds (ms).

FXAlg #968: Graphic EQ • FXAlg #969: Dual Graphic EQ

Dual mono 10-band graphic equalizers *Allocation Units: 3*

The graphic equalizer is available as stereo (linked parameters for left and right) or dual mono (independent controls for left and right). The graphic equalizer has ten bandpass filters per channel. For each band the gain may be adjusted from -12 dB to +24 dB. The frequency response of all the bands is shown in the Figure 1. The dual graphic equalizer has a separate set of controls for the two mono channels.

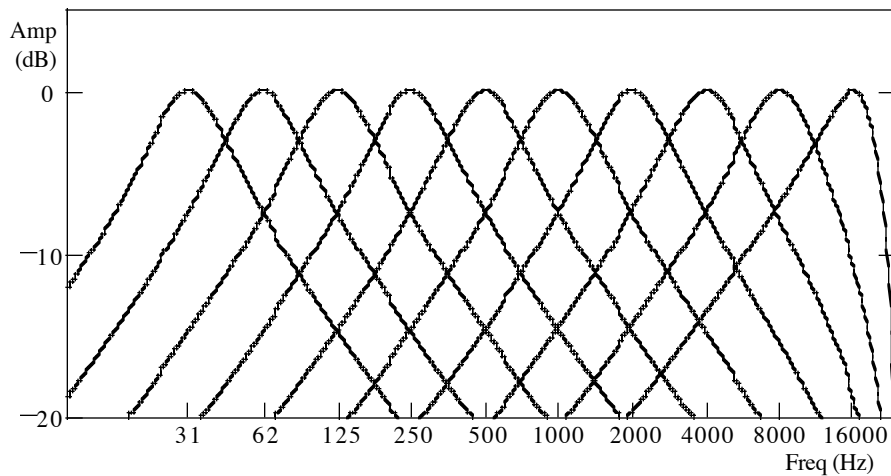

Filter Response of Each Bandpass Filter

Like all graphic equalizers, the filter response is not perfectly flat when all gains are set to the same level (except at 0 dB), but rather has ripple from band to band (see Figure 2). To minimize the EQ ripple, you should attempt to center the overall settings around 0 dB.

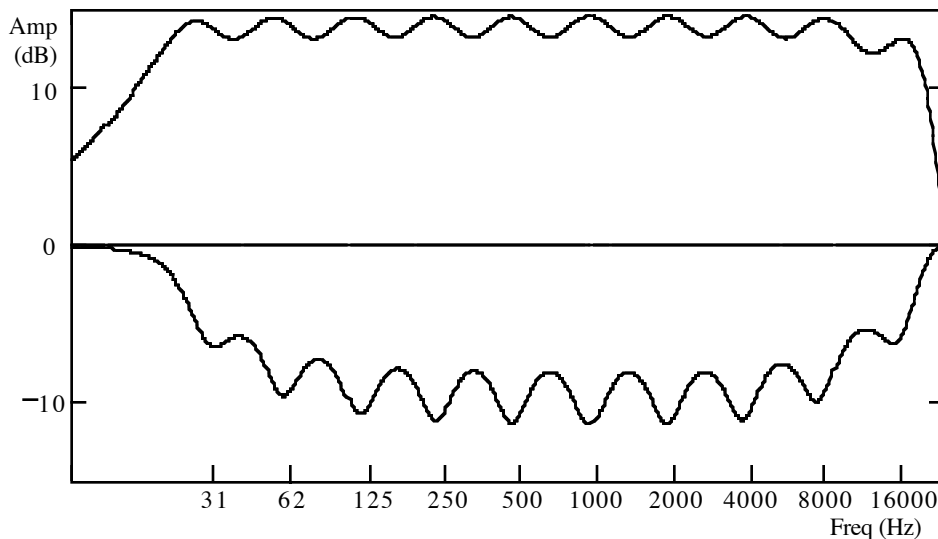

Overall Response with All Gains Set to +12 dB, 0 dB and -6 dB

Parameters (Graphic EQ):

PAGE 1

In/Out	In or Out		
--------	-----------	--	--

PAGE 2

31Hz G	-12.0 to 24.0dB	1000Hz G	-12.0 to 24.0dB
62Hz G	-12.0 to 24.0dB	2000Hz G	-12.0 to 24.0dB
125Hz G	-12.0 to 24.0dB	4000Hz G	-12.0 to 24.0dB
250Hz G	-12.0 to 24.0dB	8000Hz G	-12.0 to 24.0dB
500Hz G	-12.0 to 24.0dB	16000Hz G	-12.0 to 24.0dB

Parameters (Dual Graphic EQ):

PAGE 1

L In/Out	In or Out	R In/Out	In or Out
----------	-----------	----------	-----------

PAGE 2

L 31Hz G	-12.0 to 24.0dB	L 1000Hz G	-12.0 to 24.0dB
L 62Hz G	-12.0 to 24.0dB	L 2000Hz G	-12.0 to 24.0dB
L 125Hz G	-12.0 to 24.0dB	L 4000Hz G	-12.0 to 24.0dB
L 250Hz G	-12.0 to 24.0dB	L 8000Hz G	-12.0 to 24.0dB
L 500Hz G	-12.0 to 24.0dB	L16000Hz G	-12.0 to 24.0dB

PAGE 3

R 31Hz G	-12.0 to 24.0dB	R 1000Hz G	-12.0 to 24.0dB
R 62Hz G	-12.0 to 24.0dB	R 2000Hz G	-12.0 to 24.0dB
R 125Hz G	-12.0 to 24.0dB	R 4000Hz G	-12.0 to 24.0dB
R 250Hz G	-12.0 to 24.0dB	R 8000Hz G	-12.0 to 24.0dB
R 500Hz G	-12.0 to 24.0dB	R16000Hz G	-12.0 to 24.0dB

In/Out

In Graphic EQ, when set to "In" the equalizer is active; when set to "Out" the equalizer is bypassed.

L In/Out, R In/Out

In Dual Graphic EQ, when set to "In" the specified channel's equalizer is active; when set to "Out" the specified channel's equalizer is bypassed.

freq G

In Graphic EQ, gain of the *freq* band in dB.

L freq G, R freq G

In Dual Graphic EQ, gain of the left-channel or right-channel *freq* band in dB.

FXAlg #970: 5 Band EQ

Stereo bass and treble shelving filters and 3 parametric EQs
Allocation Units: 3

This algorithm is a stereo 5-band equalizer with 3 bands of parametric EQ and with bass and treble tone controls. The user has control over the gain, frequency and bandwidth of each band of parametric EQ and control of the gain and frequencies of the bass and treble tone controls. The controls for the two stereo channels are ganged.

Parameters:

PAGE 1

In/Out	In or Out		
Bass Gain	-79.0 to 24.0 dB	Treb Gain	-79.0 to 24.0 dB
Bass Freq	16 to 25088 Hz	Treb Freq	16 to 25088 Hz

PAGE 2

Mid1 Gain	-79.0 to 24.0 dB	Mid2 Gain	-79.0 to 24.0 dB
Mid1 Freq	16 to 25088 Hz	Mid2 Freq	16 to 25088 Hz
Mid1 Width	0.010 to 5.000 oct	Mid2 Width	0.010 to 5.000 oct

PAGE 3

Mid3 Gain	-79.0 to 24.0 dB		
Mid3 Freq	16 to 25088 Hz		
Mid3 Width	0.010 to 5.000 oct		

- In/Out When set to "In" the tone controls are active; when set to "Out" the tone controls are bypassed.
- Bass Gain The amount of boost or cut that the filter should apply to the low frequency signals in dB. Every increase of 6 dB approximately doubles the amplitude of the signal. Positive values boost the bass signal below the specified frequency. Negative values cut the bass signal below the specified frequency.
- Bass Freq The center frequency of the bass shelving filters in intervals of one semitone.
- Treb Gain The amount of boost or cut that the filter should apply to the high frequency signals in dB. Every increase of 6 dB approximately doubles the amplitude of the signal. Positive values boost the treble signal above the specified frequency. Negative values cut the treble signal above the specified frequency.
- Treb Freq The center frequency of the treble shelving filters in intervals of one semitone.
- Midn Gain The amount of boost or cut that the filter should apply in dB. Every increase of 6 dB approximately doubles the amplitude of the signal. Positive values boost the signal at the specified frequency. Negative values cut the signal at the specified frequency.
- Midn Freq The center frequency of the EQ in intervals of one semitone. The boost or cut will be at a maximum at this frequency.
- Midn Width The bandwidth of the EQ may be adjusted. You specify the bandwidth in octaves. Small values result in a very narrow filter response. Large values result in a very broad response.

FXAlg #998: FXMod Diagnostic

FXMod source-metering utility algorithm

Allocation Units: 1

The FXMod diagnostic algorithm is used to obtain a metered display of FXMod sources. This algorithm allows you to view the current levels of any data sliders, MIDI controls, switches, or internally generated VAST LFOs, ASRs, FUNs, etc. which are available as modulation sources. This algorithm has no effect on any signal being routed through it.

Up to eight modulation sources may be monitored simultaneously. Meters #1 through #4 can monitor bipolar sources, meaning sources which can have both positive and negative values. The range of the bipolar meters is -1 to +1. Four monopolar meters #5 through #8 provide better resolution, but the range is limited to 0 though +1. Use the monopolar meters for sources which you do not expect to go negative.

Eight parameters are provided to connect modulation sources to the meters. The parameter values are fixed at "NoDpth" and have no function except to connect sources to meters. To use the algorithm, save a Multieffect and Studio containing the algorithm, then go to one of the FXMod pages of your Program or Setup (with the Studio selected). Select the FX bus which contains the Multieffect using the FXMod Diagnostic algorithm, and choose one of the meter parameters (Bipole N or Monopole N). You will not be able to modify the Adjust or Depth fields, but you can select any source you want. Finally press the Edit button to re-enter the Studio and Multieffect editor where you can view the meters on parameter page 2.

Parameters:

PAGE 1

Bipole 1	NoDpth	Monopole 5	NoDpth
Bipole 2	NoDpth	Monopole 6	NoDpth
Bipole 3	NoDpth	Monopole 7	NoDpth
Bipole 4	NoDpth	Monopole 8	NoDpth

PAGE 2

1	5
2	6
-1 0 1	0 0.5 1
3	7
4	8

Bipole *n*

Use the Bipole parameters to attach bipolar modulation sources (can go positive or negative) to the bipolar meters. The parameters are not adjustable.

Monopole *n*

Use the Monopole parameters to attach monopolar modulation sources (can go positive only) to the monopolar meters. The parameters are not adjustable.

FXAlg #999: Stereo Analyze

Signal metering and channel summation utility algorithm

Allocation Units: 1

Stereo Analyze is a utility algorithm which provides metering of stereo signals as its primary function. In addition to metering, the gains of the two channels are separately controllable, either channel may be inverted, and sum and differences to the two channels may be metered and monitored. If you use this algorithm with Live Mode, you can obtain a significant amount of information not only about your own mix, but of any recording you have in your library.

There are separate meters for the left and right output channels. Two types of meters are provided: peak and RMS. Meter display units are decibels relative to digital full scale (dBFS). The peak meters display the levels of the maximum signal peak that occurred during the meter update period (every 40ms). The RMS meter displays the average power of the input signal. RMS is an abbreviation for root-mean-square, so the signal is squared, averaged and a square root is taken. For a real-time meter, we do not take an average over all time, but rather average past signals with a stronger weighting to signals in the recent past than the far past. The RMS Settle parameter controls how strong the weighting is for recent signals over much older signals. RMS Settle is expressed in units of dB/s (decibels per second), meaning how fast the RMS meter can rise or fall with changing signal levels.

You can choose to meter and monitor normal left (L) and right (R) stereo signals, or with the Out Mode parameters, you can select normalized sum and/or differences between the left and right channels. The Out Mode parameters control the signals being passed to the outputs and to the meters: what you see on the meters are the signals to which you are listening. The Invert parameters provide a polarity reversal to the input signals. This polarity reversal occurs before sum and differences. The Invert parameters are actually redundant since Out Mode provides signal inversions as well. The left and right Out Mode parameters may be set to any of the following:

L	left channel
R	right channel
(L+R)/2	normalized sum of left and right
(L-R)/2	normalized difference of left minus right
-L	polarity reversed left channel
-R	polarity reversed right channel
-(L+R)/2	polarity reversed and normalized sum of left and right
-(R-L)/2	normalized difference of right minus left

You may well ask why you would want to meter or monitor reversals or sums or differences of your stereo channels. One important case is to determine if your final mix is mono compatible—very important if your mix is ever going to be broadcast on radio or television. Set both the left and right Out Mode parameters to (L+R)/2 to listen to the mono signal. If you find that parts of your mix disappear or start to sound metallic (comb filtered), you may have to go back and do some work on your mix.

The difference signal (L-R)/2 provides a measure of the stereo content of your mix and can be very indicative of mixing style. Listening to the difference signal of someone else's recordings can often demonstrate interesting techniques (and mistakes!) in stereo production. The difference signal contains everything that doesn't make it into the mono mix. Out of phase signals will appear only in the difference signal. Panned signals will appear in both the sum and difference signals to varying degrees. A delay between left and right channels will sound metallic (comb filtered or flanged) in both the sum and difference channels. If the entire mix seems to have a relative left/right delay, you can use the L/R Delay parameter to attempt to correct the problem. Positive values delay the left channel, while negative values delay the right channel.

By inverting one channel with respect to the other, you can hear what is characterized as “phasey-ness”. Usually in stereo recordings, you can localize the phantom image of sound sources somewhere between the two loudspeakers. With a phasey signal, the localization cue get mixed up and you may hear the sound coming from everywhere or within your head. Polarity reversals are provided in this algorithm so you can test for mistakes, or simply for experimentation.

Parameters:

PAGE 1

L In Gain	Off, -79.0 to 24.0 dB	R In Gain	Off, -79.0 to 24.0 dB
L Invert	In or Out	R Invert	In or Out
L Out Mode	L	R Out Mode	R
L/R Delay	-500.0 to 500.0 samp	RMS Settle	0.0 to 300.0 dB/s

PAGE 2

Peak (-dBFS)	
L	R
55 40 * 16 8 4 0	55 40 * 16 8 4 0
L	R
RMS (-dBFS)	

- L In Gain The input gain of the left channel in decibels (dB).
- R In Gain The input gain of the right channel in decibels (dB).
- L Invert When set to on, the polarity of the left channel is reversed.
- R Invert When set to on, the polarity of the right channel is reversed.
- L Out Mode Determines which signal is to be metered (left meter) and passed to the left output. Choices are “L” (left), “R” (right), “(L+R)/2” (normalized sum), “(L-R)/2” (normalized difference), and polarity-inverted versions of these.
- R Out Mode Determines which signal is to be metered (right meter) and passed to the right output. Choices are “L” (left), “R” (right), “(L+R)/2” (normalized sum), “(L-R)/2” (normalized difference), and polarity-inverted versions of these.
- L/R Delay If this parameter is positive, the left signal is delayed by the indicated amount. If it is negative, the right channel is delayed. You can use this parameter to try to improve cancellation of the difference signal if you suspect one channel is delayed with respect to the other.
- RMS Settle RMS Settle controls how fast the RMS meters can rise or fall with changing signal levels. Units are decibels per second (dB/s).

